



SCHEDULE OF RATES

Sewerage & Drainage Works

2018-19

**With Effect from
5th October, 2018**

**Urban Development and Municipal Affairs Department
Government of West Bengal**

SCHEDULE OF RATES

For

Sewerage & Drainage Works
Considering only the Basic Price
[i.e. Exclusive OF G.S.T.]

Effective from 5th October, 2018

Urban Development and Municipal Affairs Department
Government of West Bengal

PREFACE

In continuation of Notification No. 879/MA/C-10/Misc.-19/2018 dated 17.07.2018 of UD & MA Department, Government of West Bengal, this Schedule of Rate, (SORs) for Sewerage & Drainage Works (Civil Part) has been prepared to minimize the difficulty for handling and reducing the probability of error during preparation of estimates, as well.

It is felt that one SOR under the Department of UD & MA needs to be published instead of separate SORs in different organizations under this Department in order to provide rational rate for a particular item of work for all Urban Local Bodies & Development Authorities across the State.

This Schedule of Rate, covers the items usually considered for Sewerage and Drainage works and which are not included in P.W.D. (W.B) SORs. However, to arrive at rates for consolidated items (which are frequently used by the different organizations under this Department), the rates of different kind of labours & materials have been taken from the PWD Schedule of Rates, Government of West Bengal.

Now, GST has been promulgated from 01.07.2017, so GST is to be added later on. Sample Abstract sheet for preparing estimate given herein after (Annexure X).

The Construction Labour Welfare Cess (1%) is to be added also, (Annexure X).

This will take effect on & from 5th October, 2018.

All efforts have been taken for keeping this publication error free. However, effective suggestion for any correction, addition & alteration is always welcome for any future betterment.

It is pertinent to mention here that if any other item of works that may be frequently required for execution of Sewerage and Drainage works in future shall be added to this SOR either as addendum or revised SOR.

At last, we on behalf of the Schedule Committee would like to convey our sincere thanks to those Engineer Officers who have co-operated with suggestions and also expect fruitful comment and suggestions from all concerns in future.



**Member Convenor, SOR Committee &
Secretary, MED**



**Chairman, SOR Committee &
CEO, KMDA**

ANNEXURE 'X'

Project Title: CONSTRUCTION OF PROPOSED SEWERAGE & DRAINAGE WORKS AT.....

Sl. No.	Description	Amount (Rs)
1	Cost for Sewerage & Drainage Works	X
2	Cost for Building & Sanitary Works	Y
3	Cost for Ancillary Work, if any	Z
4	Sub-total Cost (1 + 2 + 3)	$A = (X + Y + Z)$
5	GST, as applicable on Sl. No.- 4	B
6	Cost of civil works excluding labour welfare cess (4 + 5)	$C = (A + B)$
7	Labour welfare cess @1% on Sl. No. - 6	D
8	Cost of civil works including labour welfare cess (6 + 7)	$E = (C + D)$

Note: Contingency Charge @3% is to be considered on Sl. No. - 6.

CONTENTS

SUBJECT	PAGE
General Conditions.	01-02
General Specifications.	
(A) Materials	
A-1 Salt Glazed Stone Ware Pipes	03
A-2 Reinforced Concrete Pipes & Collars	03
A-3 C.I. Drainage Adjuncts	04
(B) Execution	
B-1 Preliminary Works	04
B-2 Earth work in Excavation in trenches & Shoring.	
(a) Excavation	04
(b) Shoring Works.	05
B-3 Removal of silt from Sewers/Open Drains.	06
B-4 Stone Ware Salt Glazed Pipe Laying Works & Jointing	07
B-5 Reinforced Concrete Pipe Laying Works & Jointing	08
Appurtenances	
(i) Construction of Special Inspection Chamber pit, Gully Pit, Catch Pit etc.	09
(C) Modes of Measurement works.	
C-1 Pipe Lines	11
C-2 Shoring Work	11
C-3 Retaining Shoring	11
C-4 Steel sheet piles	11
C-5 C.I. M.H. Cover & Frame, Steps etc.	11
(D) Completion Drawing	11

	SUBJECT	PAGE
Scheduled Items & Rates		
1.	Earth work in Excavtion.	12
2.	Salt glazed stoneware pipes	12
3.	Laying of R.C.C. pipe (Np3).	12
4.	Laying of R.C.C. pipe (Np2).	13
5.	Hire and labour charges for 3.75cm thick close timbering .	13
6.	Hire and labour charges for 5.0 cm thick close timbering .	14
7.	Retaining Wooden Shoring .	14
8.	Shoring with Sheet pilling.	14
9.	Concrete manhole /gully pit cover.	15
10.	C.I. inlet frame and gridfor gully pits, catch pits etc.	15
11.	C.I. Steps of approved quality and design.	15
12.	C.I. Syphon for gully pits / Catchpits.	15
13.	Dismantling & taking out old pipe sewers of any size	15
14.	Manhole connection (upto 450 mm. dia.)	15
15 & 16.	Removal of silt, slush, musks or any other foul materials.	15 - 16
17,18 & 19.	Lifting of silt slush, masks or any other foul materials.	16 - 17
20 & 21.	Construction of special inspection chamber pit..	18
22.	Construction of gullypit..	19
23.	Construction of Catch pit.	19
24	Construction of Manhole without Shaft	19
25.	Construction of Manhole with Shaft	19
	Material Cost : Cost of Np3 pipe- Spigot & Socket type Np2 pipe- Collar joint	22
	Standard Drawings.	23 - 33

General Conditions

1. The Schedule of Rates for works & materials. In all cases of contracts in respect of Sewerage & Drainage works, this entire volume of Schedule will be operative.
2. If in connection with Sewerage & Drainage Works etc. any item or items of work relating to Building works, Sanitary & Plumbing Works, Road works and Carriage crop up, the contractor shall if so directed, have to execute such items. In respect of such items the Schedule of Rates for Building Works, Sanitary & Plumbing Works, Road Works and Carriage for the current year including general conditions, general specifications etc. operative in the area will be applicable and the contractual percentage will be applicable in respect of such works as well.
3. The 'Engineer-in-Charge' shall mean the Executive Engineer of the Division concerned. The Sub-Divisional Officer concerned is authorized to carry out on behalf of the 'Engineer-in-Charge' general supervision, day to day instructions with approval of materials and workmanship. In case of dispute, the decision of the 'Engineer-in-Charge' shall be final and binding.
4. If not specifically indicated in the items themselves, the rates appearing in this schedule are inclusive of cost of all supply, carriage, handling, fitting, fixing, toll charges, ferry charges etc. all necessary jointing materials, hire charges of tools and plants, and all helping materials but exclusive of GST.
5. To arrive at complete rate of different items in this Schedule, 1% Sundries (as per requirement), 1% water charges, 5% Overhead and 10% Contractors Profit has been considered besides basic Material cost, Labour Cost and other cost involved to execute the item. All cutting holes, chases, trenches etc. at any place necessary in connection with works as per items in this schedule and subsequent mending damage as per original specification and as directed are included in the rates and shall not be paid extra unless otherwise expressly specified.
6. The contractor shall be responsible for the safe custody and proper maintenance in original condition of all sewerage & drainage works till all works are completed and formally handed over to the Department.
7. Renewal works include dismantling and taking out old work, mending good damage after renewal and removal of the waste materials. The rate for any item of original nature not provided in this Schedule may be deduced from the rate of similar item of renewal work by multiplying by a factor 100/105 and conversely the rate of any items of renewal nature not provided in this schedule may be deduced from the rate of similar item of original nature by multiplying by a factor 105/100.
8. Before application of rate, quantities of all items with metric unit must be calculated with correction 2 places of decimal when the rate is up to Rs. 100.00 and 3 places of decimal when the rate is above Rs. 100.00.
9. If not mentioned otherwise in the items themselves, all materials including fitting shall conform to standard laid down by the Bureau of Indian Standards and bear I.S.I. mark where such standardization has been made. All other materials must be of best quality conforming to the standard laid down by the I.S.I. and being approved by the Engineer-in-Charge.
10. For works within the perimeter of Jail where works are permitted within the restricted hours only, extra rate @ 10% in respect of all items of the schedule will be allowed.

All works shall be carried out with due regard to the convenience of the pedestrians & local people, if any, and the arrangement and programme of work must be adjusted accordingly. In case of works within

Jails, Hospitals etc. the Rules & Regulations of Authorities concerned must be strictly obeyed. The rates given in the Schedule are deemed to be inclusive of all such factors and contingencies.

Extra rate @ 10% for night works will be allowed.

11. All materials, tools and plants are to be arranged for the work. All labours (Skilled & Unskilled) including their housing, sanitation, procurement of food stuff, medical aids etc. are to be arranged by the contractor. Cost of transport of labour, materials and all other relevant items shall have to be borne by the contractor.
12. Arrangement of water for preparation of concrete & mortar as well as for soaking of bricks and other materials are to be made by the contractor. Construction of platforms and vats including cost thereof are to be borne by the contractor.
13. Rate of all items except those involving of labour only are to be enhanced by 30% for hill Municipalities in Darjeeling and Kalimpong districts.
14. All materials brought to site must have approval of Engineer-in-Charge. Rejected materials must be removed by the contractor from the site within 24 (twenty-four) hours of the issue of orders to that effect. In case of non-compliance with such orders, the 'Engineer-in-Charge' shall have the authority for removal of those rejected materials at the cost and expenses of contractor and the contractor shall not be entitled to any loss or damage on that account.
15. Materials obtained by dismantling Government structures or parts thereof shall remain the property of Government. The contractor shall sort out and stack the serviceable materials within the premises and also dispose of the unserviceable rubbish etc. as per instruction of the Engineer-in-Charge or his representative. The contractor shall remain the custodian of such dismantled materials till the charge of the same is taken over by the Engineer-in-Charge or his representative.
16. The site must be cleared by the contractor from time to time by removing rubbish, debris etc. as accumulated during the work and on completion the whole site must be left in a clean and tidy condition to the satisfaction of Engineer-in-Charge or his representative.
17. Number of full bricks salvaged by dismantling all types of masonry part of the structure must correspond to at least 20% of the volume dismantled.
18. Carriage of materials (unless specifically considered in the Rate Analysis) is the sole responsibility of the contractor for which no extra payment should be made (unless in exigency a few of those seem to be justified by the Engineer-in-Charge, when the same are to be approved by the concerned Superintending Engineer).

General Specification

(A) MATERIALS

GENERAL:

All materials to be used in works shall conform to Indian Standards Specification as published by B.I.S from time to time (and in the absence thereof as approved by the Engineer-in-Charge). Unless specifically mentioned otherwise the following modes of measurements shall be adopted. In general, the mode of measurement of the civil engineering works shall be guided by I.S. Code No.: 1200-1976 (Revised) for Indian Standard Method of measurement.

A-1 Salt Glazed Stone Ware Pipes:

All pipes and fittings shall be sound and free from visible defects which impair the strength, durability and serviceability. The glaze of the pipes and fittings shall be free from craving. The pipes, and fittings shall give sharp clear note when struck with a light hammer. The interior and exterior surfaces of the pipes and fittings which remain exposed after jointing shall be glazed. The portions which remain covered after jointing may or may not be glazed.

The dimensions of barrels and sockets shall be in accordance with I.S. 651-2007 or as specified in the item. The permissible variation in the internal diameter and mean thickness of the barrel and the socket of the pipe shall be in accordance with I.S. 651-2007. The length and straightness of barrels of pipes shall be in accordance with I.S. 651-2007.

The interior of the sockets shall be conical having a minimum taper of 1 in 30 at the top then at the bottom. The depth of the sockets and the width of the shoulder of the socket of any individual pipe shall be in accordance with I.S. 651-2007.

The interior of the sockets and the exterior of the spigots shall be grooved circumferentially, and such grooving on the spigot shall be for a length equal to 1.1/2 times the depth of the sockets and the depth of such grooves shall be between 1 mm and 2 mm.

A-2 Reinforced Concrete Pipes & Collars:

The design of reinforced spun concrete pipe shall conform to I.S. 458-2003. The method of manufacture shall be such that the form and the dimensions of the finished pipe are accurate within the limits specified in I.S. 458-2003. The surface and edges of the pipes shall be well defined and true and their ends shall be square with the longitudinal axis. The end of the pipes shall be further reinforced by an extra ring of reinforcement to avoid breakage during transportation. The manufacturing of the pipes shall conform to I.S. 458-2003.

Non pressure pipes are used for construction of sewers, storm drains and culverts. Normally the following classes of pipes are be used.

- (i) Class NP-2 : reinforced concrete light duty pipe for storm drains only.
- (ii) Class NP-3 : Modified NP-3: reinforced concrete heavy duty pipe for sewers and for storm drains where necessary.

The design of modified NP-3 pipe should be such that the same volume of reinforcement as that of class NP-3 is placed in single layer at a distance of 5/8th of barrel thickness from inside surface of the pipe. The dimensions of modified NP-3 pipe should conform to class NP-3 of I.S.I. 458-2003 in their respective sizes. The standard dimensions of the pipes should conform either to I.S. : 458-2003 or in this schedule.

The workmanship, finish, tests, sampling and inspection should conform to I.S. 458-2003 or as approved by the Engineer-in-charge. Inspection may be made at the place and manufacture or on the work site after delivery or at such places and at any time. On account of failure to meet any of the specified requirements even though sample pipe units may have been accepted as satisfactory at the place of manufacture such pipes shall be rejected.

The contractor/supplier shall submit certified copies of test result for the materials and finished pipe units before acceptance of the same. In spite of submission of the certified copies of test results, the Engineer-in-charge reserves the right to test any of the materials and pipe units at Contractor's /Suppliers cost.

A-3 C.I. Drainage Adjuncts:

All C.I. castings shall conform to I.S. : 210-2009. These shall be of grey cast iron. The fittings shall be clearly cast and they shall be free from air and sand holes, cold shuts and warping which are likely to impair the utility of castings. Before leaving the foundry all castings shall be thoroughly cleaned and subjected to hammer inspection. The fittings shall be coated with a material having base with a black bituminous composition. The coating shall be smooth and tenacious.

(B) EXECUTION

B-1 Preliminary Works :

The contractor shall remove all shrubs, bushes, garbages and all necessary materials from the site and make the site accessible for the movement of labour, materials and equipment and fit for the satisfactory execution of the work at his own cost.

The contractor shall demolish all structures, uproot trees & cut down their branches necessary for carrying out the work as directed by the Engineer-in-charge. Prior written permission shall be obtained from the Engineer-in-charge before execution of such jobs. All materials collected in course of clearing shall be the property of the Municipality/Corporation.

When the works in a section is taken up, the contractor shall erect temporary barricades not less than 1200 mm high on either side of the trench along the trench lines. The barricades shall be made of stout Jhau/ Eucalyptus of not less than 125 mm. dia. at the narrowest section driven into the ground at a spacing not more than 3 M. and the runners shall be of timber planks in three rows of size not less than 150 mm. size. Engineer-in-charge shall have the authority to direct the contractor to provide barricades made of G.C.I. Sheets upon the site condition and cost for hire charges for erection of such barricades shall be separately paid for. Night signal shall be provided along the barricades at a space of 6 M. apart of each night signal. The cost for provision of night signal is deemed to be include in the overall rate of works and shall not be paid separately.

B-2 Earth work in Excavation in trenches & Shoring :

(a) Excavation:

Earthwork in excavation as included in pipe laying work, either for sewer or water main or pressure main of any kind include cutting through bituminous layer over water bound macadam road of any thickness, stone set roads and side walks including sub-grade concrete pad and excavation through all kind of soil, sludge, musks, silt, sand or loose materials existing in place. Unless otherwise specified or instructed by the Engineer-in-charge, all excavation shall be open cut and the side of trenches shall be kept vertical. Before taking up excavation, the width or excavation shall clearly be marked on the ground surface and damage to the existing prevents beyond those limits should be avoided. A minimum of 100 cm. berm shall be provided on either

sides of the trench which should be kept free from spoils and materials. Excavating shall include throwing the excavated earth at least one metre or half the depth of excavation, whichever is more, clear of the edge. Where the excavation will be through an existing pavement of water bound macadam, bituminous or stone set road, the materials like road metals, brick, stone set, flag stones, concrete blocks etc. should be salvaged, screened and preserved separately in stack at road side spaces without any admixture with excavated sub-soil. The salvaged road materials will however be utilised for temporary road restoration work.

There shall be no extra payment for sand boiling or silt clearance during excavation. Spoils excavated from trenches except the material needed for filling shall not be stacked at the work site. As the excavation of a section of a trench proceeds, the quantity of excavated earth selected for filling shall, unless otherwise specified elsewhere in the tender documents, be dumped within 75 M. in a convenient place indicated by the Engineer-in-charge. This quantity of earth will be brought back for filling the trench after the sewers, drains, pipes etc. are laid and tested. The cost of carrying away and bringing back such quantity of earth as required for filling shall be deemed to be included in the over-all cost of excavation work in adjoining section is undertaken, the surplus earth from a joining section may be used for filling of the completed portion as per direction of Engineer-in-charge. The contractor shall remove any sort of stump of trees, logs, debris or/and other buried loose materials encountered during the course of excavation for which no extra payment will be made.

The Engineer-in-charge shall have the power to require the contractor to take up any section of the works in preference to another and to limit the extent of any excavation to be made at one time and the contractor shall comply with the same and expedite the completion of any such particular section/component of work as per direction of Engineer-in-charge.

Any excavation made below the level or grade as indicated on the plans should be refilled of specified level or grade at the contractor's expenses with sand or jhama khoa cement concrete (1:3:6) as may be directed by the Engineer-in-charge and to his satisfaction. With progress of excavation, if any pipe, Conduit, electric cable, telephone cable gas main or other underground structure is encountered, digging by general equipment shall be discontinued and the excavation shall be done with the help of hand tools or by special equipment for such excavation for which no extra payment will be made.

The contractor shall have no ownership right for any excavated materials. The rate for excavation shall be deemed to be included of all costs of excavation and stacking of spoil for back fill and removal of surplus spoils. Dewatering required to be done for excavation is included in the item and unless specifically approved by the Engineer-in-charge, no separate payment for dewatering during excavation is admissible.

(b) Shoring Works

(i) Timber shoring:

Timber shoring shall be of well seasoned hard Wood of requisite strength, good quality, free from knots and cracks and preferably treated with preservations. The shoring work shall include providing bracings and strut sand it should be strong enough to support the sides of excavation and to prevent any movement of soil, the planks should be sufficiently long and fixed continuously as directed by the Engineer- in-charge.

Shoring materials shall be provided by the contractor, shoring materials furnished by the contractor shall be removed from the site immediately on completion of work. If the Engineer-in-charge is of opinion that at any place, sufficient or proper shoring has not been provided he may order of additional shoring and further strengthening at the contractors, expenses. The contractor shall bring to site sufficient quantity of shoring materials ahead of starting to excavation depending on the volume of works involved and the speed to be attained to complete the works within the stipulated time. As far as practicable, shoring shall be driven ahead of excavation and finally to a depth sufficiently below the bottom of the trench not less than 15 cm. in any case

the height of shoring planks shall not be less than 1.0M. above existing G.L. for proper withdrawal of planks as well as protection of trench.

(ii) Retaining Shoring:

Whenever so directed by the Engineer-in-charge, the contractor shall leave in place the shoring to be embedded in the filled up trench with runners cross struts etc. The projected portion of the shoring shall be cut at 30 cm. below the established street level or the existing surface of the street as directed by the Engineer-in-charge.

(iii) Steel Sheet Piles:

The steel piles may be used at difficult sites either for very deep trench or at sites where there are changes of collapse of buildings or structures. The steel sheet piles are to be used whenever required with specific written permission of Engineer- in-charge.

The steel sheet piles are to be procured by the contractor for which hire charge will be paid.

The driving of M.S. sheet piles is to be done in all kinds of soil including excavation of hard crust. The piles will have to be driven very carefully avoiding damages to underground cables, pipes etc. true to plumb along the alignment upto the required depth. The driving of sheet piles shall also include driving of junction, corners, taper, piles clutch bars etc. where necessary. The rate is inclusive of cutting to sizes, making necessary arrangement for hoisting in position, drilling holes, hire charges of mechanical equipment. The piles will have to be taken out or re-driven by the contractor at his own cost if not driven to design depth or to plumb or alignment. Proper sheet pile caps will have to be used in order to prevent damage to the head of the piles. In case sheet piles are used for temporary works, e.g., shoring of trenches, all sheet piles will have to be extracted after completion of permanent works as per direction of Engineer-in-charge. However, if sheet piles are not extracted, the cost of unextracted sheet piles will be realised from the contractor.

B-3 Removal of Silt from Sewers/Open Drains:

Removal of silt, slush, musk or any other foul materials shall be removed from the conduit by means of buckets, pans etc. manually or by mechanical devices. The man-entry sewers are where entry and approach within the sewer is possible. Before taking up of such sewer cleansing work, several consecutive manholes are to be opened and sufficient air has to be blown through the sewer by means of air blower or any other device in order to remove inflammable, foul or asphyxiating gases from within the sewer for avoiding any accident. The silt from inside of such sewers are to be escaped out along the length of the conduit and removed by buckets, manually or by mechanical device and temporarily dumped on road side at a convenient place to that the same may not cause any difficulty to passerby or traffic and will be disposed off at designated place as would be decided by the concerned Department.

Where the size of sewer is such that entry within the sewer is not possible, cleaning of sewer shall be done by conventional method of 'roping' and silt removed from the manholes as described earlier. For open drains or channels, a section of drain or channel shall be provided with temporary cross bundhs which will be removed after the day's work. During erection of this work, the site has to be provided with necessary guards and night signals, so that no accident may occur.

The site so removed either from the sewers or from open drain shall be retained in stacks at least for 24 hours or as directed by the Engineer-in-charge. Transportation of silt, slush or other foul materials from the working site and disposal of the same beyond the area of the Municipality/ Corporation including the cost of loading, unloading, transportation and making arrangement of necessary land for disposal, spreading and leveling as necessary etc. complete (Land for disposal to be arranged by the contractor).

B-4 Stone Ware Salt Glazed Pipe Laying Works & Jointing :

General

Supplying and laying S.W. pipes including cement gasket joint (1:2) on jhama cement concrete bed (1:4:8) over a layer of brick flat soling encasing the pipe with jhama cement concrete (1:4:8) in conformity with I.S. - 4127-1983 and standard drawing, dewatering during excavation and keeping the trench reasonably dry till all pipes laying works and encasing the concrete are complete, back filling with excavated earth or with sand or cinder if specifically directed by the Engineer-in-charge for which separate payment will be made and temporary road restoration with recovered road materials by power roller and removal of surplus spoils but excluding shoring.

(i) Laying of S.W. Pipes :

When unloading, pipes shall not be thrown down from the trucks on hard ground. Unloading them on timber skids without steadying rope and thus allowing the pipes to bump hard against cone another should not be allowed. In order to avoid damage to the pipes and especially to the spigot end, pipes should not be dragged along concrete or similar pavements with hard surface. In shallow-trenches manual handling is enough, but in deep trenches, they should be lowered into the trench by means of ropes. Under no circumstances shall the pipes be dropped or dumped into the trench. All pipes shall be carefully inspected before being laid. Deformed, broken edge or pipe not of uniform colour should be removed. All lumps, blisters and excess coating materials shall be removed gently from the socket and spigot ends of each pipe and the outside of the spigot and inside of the socket shall be wiped clean and dry before the pipe is laid.

Every precaution shall be taken to prevent foreign materials from entering the pipes when it is being placed in the line normally, the socket end should face the upstream. After placing a length of pipe in the trench on concrete bedding the spigot end shall be centered in the socket and the pipe forced home and aligned to gradient. Pipe and fittings which do not allow a sufficient and uniform space for joints shall be removed and replaced with pipe and fittings of proper dia mentions to ensure such uniform space. Precaution shall be taken to prevent dirt from entering the joint space. At times, when pipe laying is not in progress, the open ends of pipe shall be closed by temporary wooden plugs or canvas. Each pipe unit or fitting shall be so laid as to form a close joint with the adjoining pipe and bag the inverts continuously to the required grade with the help of sight rails and bonning rods.

The cutting of pipe or inserting fitting or closer prices shall be done in neat and workman like manner without damage to the pipe so as to leave in smooth and at right angles to the axis of the pipe.

The pipes when laid should not be subjected to superimposed load beyond their safe crushing strength.

The connection to an existing sewer shall be done through man-holes.

(ii) Jointing of S.W. Pipe :

After the pipe units are aligned and laid in the trench jointing is to be done after thorough cleaning of the joint surface. In each joint spun yarn soaked in neat cement slurry or tarred gasket shall be passed round the joint and inserted in my caulking tool.

The gasket after being thoroughly caulked, shall not occupy more than one fourth the depth of socket and the rope should be fully encircle the spigot with a slight over lap. The remainder of the annular space is to be hand packed by cement mortar (2:1) and then thoroughly caulked with a caulking tool. The joint shall then be finished off nearly and levelled smoothly at an angle of 45° with the outside of the pipe. The cement mortar joint shall be cured at least for seven days before testing.

Each length of pipe sewer shall be completed from manhole to manhole unless other wise directed, perfectly straight and true in level and gradient and the trench shall not be filled in until the length has been inspected, tested and passed by the Engineer-in-charge or his representative. Should it be found before the expiration of the period of maintenance that any length of sewer between certain manholes has become out of alignment or grade, leaky or damaged, the contractor shall at their own expense readjust the work as per instruction of Engineer-in-charge.

(iii) Hydraulic Testing of stone Ware Pipe Sewer Line:

The hydraulic testing of stone ware pipe sewer lines are to be done in accordance with I.S. 4127-1983. All new sanitary sewers upto 450 mm. dia except in cases where sewerage facilities have been extended, shall be subject to a test pressure of at least 2.5 M. head of water at the highest point of the section under test. The tolerance of two liters per centimeter of diameter per kilometer may be allowed during a period of ten minutes. The methods of testing should be adopted as per direction of the Engineer-in-charge. Any leakage which will be visible and the defective part of the work shall be cut out and made good. A slight amount of sweating, if uniform may be allowed, but excessive sweating from a particular pipe or joint shall be watched for and taken as indicating a defect to be made good any joint found sweating or leaking shall be rectified or embedded into 15 cm. layer of concrete 30 cm. in length and section restored. Filling of the trench shall not be commenced until the lengths of pipes there in has been tested and passed.

B-5 Reinforced Concrete Pipe Laying Works & Jointing :

General:

Supplying and laying class NP₂ or NP₃ pipes with collars, painted inside with one coat of coal tar, lowering and laying the pipes in the trench on jhama cement concrete bed (1:3:6) over a layer of brick flat soling in prescribed depth and alignment, filling the end grooves of the pipe with bitumastic compound and jointing the ends by collar with tarred gasket or jute yarn soaked with neat cement slurry and cement mortar (1:2) as per I.S. 783-2001 and standard drawing., dewatering during excavation and keeping the trench reasonably dry, till all the pipes laying works, jointing with collars and haunching of sides with jhama cement concrete (1:3:6) are complete, back filling with excavated earth or with sand or cinder if specifically directed by the Engineer-in-charge for which separate payment will be made and temporary road restoration with recovered road materials by power roller and removal of surplus spoils but excluding shoring.

(a) Laying of R.C.C. Pipe :

While unloading from trucks, pipes and fittings shall not be dropped loose on the ground and hard roads. Care should be taken to unload them on timber skids with the steadying rope so as not to allow the pipes to bump against one another. In order to avoid damage to the pipe and specially to ends, it shall not be rolled or dragged along the concrete pavements and similar pavements with hard surface. All pipes and collars shall be carefully inspected before being laid. Broken or defective pipes and collars shall not be used.

All lumps, blisters and excess coating materials shall be removed gently from the pipe surfaces and ends of each pipe shall be wiped, cleaned, and dried before the pipe is laid. Before lowering the pipes or fittings into the trenches each unit shall be inspected. Each unit before lower into the trench shall be provided with a bituminous coating inside the properly dried.

Each pipe unit shall be handled and placed in position inside the trench properly and gently. Under no circumstances shall any pipe unit be dumped or rolled into the trench or be allowed to drop against the pipe already in the trench. Mechanical means for lowering of pipes are preferable.

Each pipe unit shall be so laid as to form a close joint with the adjoining pipe and bring the inverts continuously to the required grade with the help of sight rails and bonning rods. Trenches shall be kept reasonably free from water until the material in the joints has hardened.

The cutting of pipes when required shall be done in a neat and workman like manner without damage to the pipe so as to leave a smooth and at right angles to the axis of the pipe. The contractor shall take all necessary precautions to prevent floatation of the pipe in the trench and dirt from entering the joint space. At all times when pipe laying is not actually in progress, the open ends of pipe shall be closed by temporary wooden plugs or canvas. Whenever it is required to lay the sewer on reinforced concrete raft foundation over sal bullah piling, the sal bullah piles shall be of necessary length and diameter not less than 150 mm and shall be painted with a coat of coal tar. The piles shall be driven by a monkey hammer upto the trench bottom. Walking or working on the completed pipe shall not be permitted until and trench has been backfilled to a height of at least 30 cm. over the pipe except as may be necessary in tamping or back filling. Filling of the trench shall be carried on simultaneously on both sides of the pipe in such a manner so that unequal pressure does not occur.

(b) Jointing of R. C. C. Pipe :

After the pipes and fittings are laid into the trench, the jointing is to be done after through cleaning of the joint surfaces. Rigid collar joint shall be made in accordance with I.S. 783-2001 or as per direction of Engineer-in-charge. The caulking space is to be filled up with tarred gasket or gasket soaked in neat cement slurry and cement mortar (2:1) as per direction of the Engineer-in-charge.

After jointing, the cement mortar joints shall be thoroughly cured for at least 48 hours or longer if directed by the Engineer-in-charge.

Each section or length of R.C.C. pipe sewer/drain shall be completed perfectly straight and true in level and gradient and trench shall not be filled in till the length has been inspected and passed by Engineer-in-charge. Should it be found before expiration of the period of maintenance that any length of sewer/drain has become out of alignment, leaky or damaged, the contractor shall at their own expenses rectify the defect as per direction of Engineer-in-charge.

(c) Appurtenances:

(i) Construction of Manhole, Special Inspection Chamber Pit, Gully Pit, Catch Pit etc. :

All manhole structures, Special Inspection Chamber Pits, Gully Pits, Catch Pits etc. shall conform to the spacing, size, dimensions and other details as per standard drawing or as directed by Engineer-in-charge. All those structures shall be constructed on a firm foundation. The work shall include earthwork in excavation including cutting hard crust, construction of structures with cement brick work on cement concrete bed foundation over a layer of soling including dewatering, during execution of work, back filling and removal of surplus spoils. The top of chambers shall be provided with a reinforced concrete slab with specified reinforcement. For manholes and special inspection chamber pit the shaft for entry into manholes crust inspection chamber pit shall be of cement brick work. The invert shall constitute cement brick work with a channel accurately shaped and shall conform to the size of the out going pipe and provided with cement concrete benching on both sides at least 150 mm. wide. Inside of all exposed brick work and invert shall be plastered with cement finished fine with neat cement.

The pipes built inside the chambers shall be encased with stone chips cement concrete. No portion of pipe shall project within the chamber. All C.I. / RCPC frames either for cover or for grating shall not be embedded with concrete, but shall be laid over cement mortar and sides provided with cement concrete levelled upto the edge of the brick work or upto 150 mm. width on all sides.

Manholes and special inspection chamber pits shall be constructed at every intersection, bends, change of size of sewer or at specified distance for a straight length of pipe line as below :

Dia of Pipe	Average spacing of MH/SIC
(a) Upto 450 mm.	15 Meter
(b) Above 450 mm & Upto 900 mm	30 Meter
(c) Above 900 mm.	30 Meter

Special Inspection pit shall be constructed in smaller lanes where traffic load is minimum. The weight of C.I. manhole cover and frame, cover and frame of Special Inspection Chamber pit, gully grids and catch be provided with C.I. Steps and to be built during brick work in a staggered manner vertically at a distance of 230 mm. All manholes and Special Inspection Chamber pits shall be constructed during the process of pipe laying work.

Standard manholes or Special Inspection Chamber pits shaft shall be constructed in roads considering intensity of traffic load and for any depth beyond a depth of invert upto 1.80 Meter below G.L. where the depth of invert below G.L. is less than 1.80 Meter, only manhole or Special Inspection Chambers shall be constructed without shaft with a minimum depth of 1.25 M and 1.15 M. respectively. Width of manhole of or S.I.C. may be increased as per necessity with increase of pipe diameter but minimum width shall not be less than 750 mm. in case of manholes and 600 mm in case of S.I.C.P (inside measurement). However, the inside dimension of length of S.I.C.P or standard manholes shall always be 1500 mm and 900 mm respectively.

The gully pit or catch pit shall be constructed as specified above except benching but shall be provided with C.I. syphons and R.C.P./C.I. gully grating of appropriate size. For wider roads gully pits shall be provided on both sides of the carriage way at an average spacing of 22 Meter apart or as directed by the Engineer- in-charge. The catch pit shall normally be provided in narrow lanes / bustee passages etc. at an average spacing normally be provided at valley points. At every crossing of roads, turning points etc. The standard size of the gully pits and catch pits shall be 1100 mm x 625 mm. (inside measurement) and a depth of invert of 1500 mm. below G.L. and 600 mm x 525 mm (inside measurement) and depth of invert 1000 mm. below G.L. All gully pits shall be provided with syphons, steps and inlet grating of appropriate size.

Adequate arrangement shall be made for collection of surface water through gully pits and catch pits shall be made necessary channeling in proper gradient.

(C) Modes of Measurement

General :

Quantities of work and materials to be paid for will be measured and determined by the Engineer-in-charge according to specification and drawings and the working instruction that may be given by him. No clearance will be made for any excess above the quantities required by the specifications drawing and instructions on any part of the work, except where such excess materials has been supplied or work done by written order of the Engineer-in-charge and that for no fault or negligence on the part of the contractor. Should the dimensions of any part of the work or of the materials be less than these required by the drawing or the directions of the Engineer- in-charge but have been accepted by him only the actual quantity of work done and materials supplied shall be allowed in measurement except where otherwise provided in the specifications the following modes of measurement shall be adopted.

C-1 Pipe Lines:

All pipe lines are to be measured on the basis of length of each unit laid between the two manholes. The measurement of encased pipes shall be made after laying pipes and jointing completed between the two manholes immediately after jointing but before encasing or filling up of the trench.

Length of pipe actually inserted within the brick work will be paid.

C-2 Shoring Work :

All timber shoring work shall be measured from ground level upto excavation level in contract with earth. The portion of shoring driven within the trench below excavation level and the portion kept raised over ground level shall not be measured. No separate measurement for cross supports will be taken into account.

C-3 Retaining Shoring:

Measurement for retaining shoring shall be taken for actual portion of shoring left within the trench. No payment for the portion cut below ground level is admissible for measurement. No measurement shall be taken for cross supports, left within the trench.

C-4 Steel Sheet Piles:

The measurement of steel sheet piles shall be made in accordance with I.S. 1200 (Part - XXIII) 1988 .

Shifting, handling, pitching through inter-lock or clutches of adjacent sheet piles and driving shall be measured in Sqm. Meters obtained by multiplying the length of the embedded portion of the pile in soil and width along the centre line of the alignment for piling and not the curved faces of sheet pipe. The length of the embedded portion shall be obtained by measuring from the level of the ground where the tip of the piles first touches before driving, to the ultimate level of the tip of the piles after driving.

Withdrawal of piles, other than the case of defective driving, and installations necessitating withdrawal of piles already driven and re-driving (where no separate measurement shall be taken) shall be measured separately in Sqr. meters obtained by multiplying the embedded length of pile in soil by the width of piles along the centre line of the alignment of piling. In case of defective driving and installations of piles necessitating extraction of piles already driven and re-driving, no separate measurement shall be taken.

C-5 C.I.,M.H. Cover & Frame, Steps, Inlet Frames Grating, Syphon Etc. :

The C.I. items are inclusive of composite items for which these are meant for. However, if separate items are required to be executed in view of site condition those will be paid in Kg. of the respective item which includes works necessary for installation of these items.

Any other work e.g., brick work, plastering, centering etc. which if necessary for execution, shall be measured in conformity with the item and mode of measurement specified in P.W.D. Schedule of rates 2017.

(D) Completion Drawing

All works executed, shall be drawn to scale as per direction of Engineer-in-charge with sufficient number of prints and original in tracing cloth or Micro film showing all details of measurement, levels both in plan and section and where ever applicable with elevation and submitted along with final bills.

Sl.No.	Description of item	Unit	Rate (Rs.)	Remarks
1	Earth work in excavation of foundation trenches or drains, in all sorts of soil (including mixed soil but excluding laterite or sandstone) including removing, spreading or stacking the spoils within a lead of 75 m. as directed. The item includes necessary trimming the sides of trenches, levelling, dressing and ramming the bottom, bailing out water as required complete. (Excluding cost of shoring).			
	(a) Beyond 4000 mm to 6000 mm below G.L.	%Cum	27702.00	
	(b) Beyond 6000 mm to 7500 mm below G.L.	%Cum	31934.00	
	(c) Beyond 7500 mm to 9000 mm below G.L.	%Cum	36165.00	
2	Supplying, fitting and fixing with cement jointing (3:1) salt glazed stoneware pipe excluding excavation of earth work, refilling and concreting at bottom and sides).			
	i) 375 mm. dia.	Mtr	2597.00	
	ii) 450 mm dia	Mtr	3491.00	
3	Laying of R.C.C. pipe with spigot - socket/Roll on jointed pipe, lowering the same into the trench laying on the bed in trenches in prescribed gradient, depth and alignment, filling the end grooves with necessary bitumastic compound, filling caulking space with tarred gasket or with rubber gasket of appropriate size & covering with cement mortar (1:2) & testing the joints etc. complete as per drawing, specification including carriage of pipes from site stacks to the place of laying etc. & as per direction of the Engineer-in-charge. (Payment to be made on the basis of actual finished length of the pipe line).			
	A) Class NP-3 Pipe			
	a) 2000 mm dia	Mtr	1596.00	
	b) 1800 mm dia	Mtr	1355.00	
	c) 1600 mm dia	Mtr	1234.00	
	d) 1500 mm dia	Mtr	1166.00	
	e) 1400 mm dia	Mtr	1013.00	
	f) 1200 mm dia	Mtr	881.00	
	g) 1100 mm dia	Mtr	842.00	
	h) 1000 mm dia	Mtr	727.00	
	i) 900 mm dia	Mtr	659.00	
	j) 800 mm dia	Mtr	579.00	

Sl.No.	Description of item	Unit	Rate (Rs.)	Remarks
	k) 750 mm dia	Mtr	525.00	
	l) 700 mm dia	Mtr	509.00	
	m) 600 mm dia	Mtr	333.00	
	n) 500 mm dia	Mtr	256.00	
	o) 450 mm dia	Mtr	237.00	
	p) 400 mm dia	Mtr	229.00	
	q) 375 mm dia	Mtr	201.00	
	r) 300 mm dia	Mtr	169.00	
	s) 250 mm dia	Mtr	161.00	
	t) 225 mm dia	Mtr	156.00	
	u) 200 mm dia	Mtr	153.00	
	v) 150 mm dia	Mtr	113.00	
4	Laying of R.C.C. pipe with collar, lowering the same into the trench laying on the bed in trenches in prescribed gradient, depth and alignment, filling the end grooves with necessary bitumastic compound, filling caulking space with tarred gasket or with rubber gasket of appropriate size & covering with cement mortar (1:2) & testing the joints etc. complete as per drawing, specification including carriage of pipes from site stacks to the place of laying etc. & as per direction of the Engineer-in-charge. (Payment to be made on the basis of actual finished length of the pipe line). A) Class NP-2 Pipe			
	a) 900 mm dia	Mtr	563.00	
	b) 750 mm dia	Mtr	457.00	
	c) 600 mm dia	Mtr	274.00	
	d) 450 mm dia	Mtr	204.00	
	e) 300 mm dia	Mtr	168.0	
	f) 250 mm dia	Mtr	161.00	
	g) 225 mm dia	Mtr	157.00	
	h) 200 mm. dia	Mtr	153.00	
	i) 150 mm dia	Mtr	113.00	
5	Hire and labour charges for shoring work (including necessary close plank walling, framing, Eucalyptus/Jhou bulla piling, strutting etc) complete as per direction of the Engineer-in-charge for excavation works (vertical surface are in contact with supported earth is to be measured.) (This item should be executed on specific direction of the Enginner in charge).			

Schedule of Rates

Sl.No.	Description of item	Unit	Rate (Rs.)	Remarks
	With 3.75 cm. thick timber planks. For trench width upto 1.0 M a) Depth upto 3.00 M below G.L. b) Depth beyond 3.00 M. upto 4.50 M below G.L.	Sqm Sqm	496.00 540.00	
6	Hire and labour charges for shoring work (including necessary close plank walling, framing, Eucalyptus/ Jhou bulla piling, strutting etc) complete as per direction of the Engineer-in-charge for excavation works (vertical surface are in contact with supported earth is to be measured.) (This item should be executed on specific direction of the Enginner in charge). With 5.0 cm. thick timber planks. For depth upto 6.00 M below G.L. a) Beyond 1.0 M. upto 2.0 M trench width. b) Beyond 2.0 M. and upto 4.0 M. trench width c) Beyond 4.0 M. and upto 6.0 M. trench width	Sqm Sqm Sqm	727.00 754.00 790.00	
7	Retaining wooden shoring in place with necessary planks, runners etc. including the cost for driving the same and cutting the shoring as directed and complete for all depths and widths to trenches (under the specific instruction of the Chief Engineer) (N.B. While allowing payment for retaining shoring no payment for providing shoring vide item no. 5 & 6 above shall be made.) i) 3.75 cm. thick. ii) 5 cm thick.	Sqm Sqm	1204.00 1502.00	
8	Hire and labour charges for shoring with Sheet pile (8 mm thick) & ISMB-250 runner, struts, anchor, tie etc. complete. Beam section conforming to IS-226 IS:808 & SP(6)-1964 including cutting to requisite length, fabrication with necessary welding conforming to IS: 816-1956 & IS: 1995 using electrodes of approved make and brand conforming to IS: 814-1957 including driving and complete removing them as per direction of the Engineer-in-Charge. For overall depth of excavation from G.L., a) 4.0 M to below 5.0 M. b) 5.0 M to below 6.0 M. c) 6.0 M to below 7.0 M. d) 7.0 M to below 8.0 M. e) 8.0 M to above.	Sqm Sqm Sqm Sqm Sqm	9396.00 10940.00 12485.00 14030.00 15574.00	

Sl.No.	Description of item	Unit	Rate (Rs.)	Remarks
9	Supplying, fitting and fixing in position reinforced cement polymer concrete manhole /gully pit cover with matching frame. As per I.S-12592(M.D) i) 15 MT load bearing capacity gully pit cover with frame and hinge arrangement for opening of size Cover : 565 mm. X 410 mm. X 90 mm. Frame : 715 mm. X 565 mm. X185 mm. Weight: 140 Kg. (approx.)	Each	3465.00	
10	Supplying, fitting and fixing of any type of C.I. inlet frame and grid for gully pits, catch pits etc. & 600 mm. dia. heavy duty C.I. manhole cover (minimum weight 100 Kg.) and frames (minimum weight 100 Kg.) of approved design [Note : Excluding necessary bituminous coating]	Kg	68.00	
11	Supplying, fitting and fixing C.I. Steps of approved quality and design.	Kg	77.00	
12	Supplying, fitting and fixing C.I. syphon for gully pits / catchpits. a) 150 mm. dia. b) 225 mm. dia.	Each Each	2016.00 3683.00	
13	Dismantling & taking out old S. W. pipe upto 450 mm diameter and stacking the same as per direction of the Engineer-in-Charge.	Mtr	64.00	
14	Manhole connection (upto 450 mm. dia.) including mending good all complete with (1:2:4) cement concrete as per specification and direction of Engineer-in-charge.	Each	388.00	
15	Cleaning rubbish, sludge, weeds scum, liquid earth, mud etc. from road side masonry open drain/ nikashi etc. by mathor labour after removing concrete slab / manhole cover etc. without damaging the same and refixing the same properly after cleaning as necessary and removing the sludge etc. by using iron pans, buckets including all labour, tools & plants including expulsion of impure/ inflammable/asphyxiating gases from the drains etc. and removing the spoils in dry condition and disposing the same by truck beyond the area of Municipal Corporation / Municipality / Notified Area Authority / Industrial Township Authority etc. for such disposal including the cost of loading, unloading, transportation and making arrangement of necessary land for disposal, spreading and			

Schedule of Rates

Sl.No.	Description of item	Unit	Rate (Rs.)	Remarks
	leveling as necessary etc. and cleaning the road side in all respects, complete as per direction of the Engineer-in-Charge. (Land for disposal to be arranged by the contractor). (Payment will be made on the basis of actual stack measurment of spoils in dry condition at roadside) For Day :	Cum	735.00	
16	Cleaning rubbish, sludge, weeds scum, liquid earth, mud etc. from box drain/ covered nikashi etc. by mathor labour after removing concrete slab / manhole cover etc. without damaging the same and refixing the same properly after cleaning as necessary and removing the sludge etc. by using iron pans, buckets including all labour, tools & plants including expulsion of impure / inflammable / asphyxiating gases from the drains etc. and removing the spoils in dry condition and disposing the same by truck beyond the area of Municipal Corporation / Municipality / Notified Area Authority / Industrial Township Authority etc. for such disposal including the cost of loading, unloading, transportation and making arrangement of necessary land for disposal, spreading and leveling as necessary etc. and cleaning the road side in all respects, complete as per direction of the Engineer- in-Charge. (Land for disposal to be arranged by the contractor). (Payment will be made on the basis of actual stack measurment of spoils in dry condition at roadside) For Day :	Cum	806.00	
17	Cleaning rubbish, sludge, weeds scum, liquid earth, mud etc. from conduits of any dia. above 900 mm and from any depth , etc. by mathor labour after removing concrete slab / manhole cover etc. without damaging the same and refixing the same properly after cleaning as necessary and removing the sludge etc. by using iron pans, buckets including all labour, tools & plants including expulsion of impure / inflammable / asphyxiating gases from the drains etc. and removing the spoils in dry condition and disposing the same by truck beyond the area of Municipal Corporation / Municipality / Notified Area Authority / Industrial Township Authority etc. for such disposal including the cost of loading, unloading, transportation and making arrangement of necessary land for disposal, spreading and leveling as necessary etc. and cleaning the road			

Sl.No.	Description of item	Unit	Rate (Rs.)	Remarks
	side in all respects, complete as per direction of the Engineer- in-Charge. (Land for disposal to be arranged by the contractor). (Payment will be made on the basis of actual stack measurement of spoils in dry condition at roadside) For Day:	Cum	948.00	
18	Cleaning rubbish, sludge, weeds scum, liquid earth, mud etc. from conduits of any dia. upto 900 mm and from any depth , etc. by mathor labour after removing concrete slab / manhole cover etc. without damaging the same and refixing the same properly after cleaning as necessary and removing the sludge etc. by using iron pans, buckets including all labour, tools & plants including expulsion of impure / inflammable / asphyxiating gases from the drains etc. and removing the spoils in dry condition and disposing the same by truck beyond the area of Municipal Corporation / Municipality / Notified Area Authority / Industrial Township Authority etc. for such disposal including the cost of loading, unloading, transportation and making arrangement of necessary land for disposal, spreading and leveling as necessary etc. and cleaning the road side in all respects, complete as per direction of the Engineer- in-Charge. (Land for disposal to be arranged by the contractor). (Payment will be made on the basis of actual stack measurement of spoils in dry condition at roadside) For Day :	Cum	1162.00	
19	Cleaning of floating materials / garbage / any other foul materials from incoming sewer of drainage pumping station / adjoining penstock gate / open Nikashi / Lock Gate at Canal etc. by mathor labour after removing concrete slab / manhole cover etc. without damaging the same and refixing the same properly after cleaning as necessary and removing the sludge etc. by using iron pans, buckets including all labour, tools & plants including expulsion of impure / inflammable / asphyxiating gases from the drains etc. and removing the spoils in dry condition and disposing the same by truck beyond the area of Municipal Corporation / Municipality / Notified Area Authority / Industrial Township Authority etc. for such disposal including the cost of loading, unloading, transportation and making arrangement			

Schedule of Rates

Sl.No.	Description of item	Unit	Rate (Rs.)	Remarks
	of necessary land for disposal, spreading and leveling as necessary etc. and cleaning the road side in all respects, complete as per direction of the Engineer- in-Charge. (Land for disposal to be arranged by the contractor). (Payment will be made on the basis of actual stack measurment of spoils in dry condition at roadside)	Cum	877.00	
20	Constructing Special Inspection chamber pit (size 900 mmX600 mm) to a depth of 1.15 metre (inside), 250 mm thick 1st class brick work (1:4) in all sides over a layer of jhama brick soling and 150 mm thick Jhama cement concrete (1:4:8) including necessary earth work, invert with ordinary cement concrete (1:2:4) with stone chips over brick-on-edge flooring, plastering inside with 20 mm thick cement plastering (1:4) and neat cement punning, including supplying, fitting and fixing one 450 mm. dia (15 MT) heavy duty RCPC manhole cover of approved make with R.C.C. slab of 100 mm thick with cement concrete (1:1.5:3) with stone chips including necessary reinforcement, shuttering and CI foot steps (4 kg each) (Depth of invert between 1.15 m to 1.80 m below G.L.)	Each	18392.00	
	ii) Addition and deduction of rate of special inspection chamber pit as per above item for each addition or reduction in depth of 150 mm. or part thereof.	Each	1053.00	
21	Constructing Special Inspection chamber pit (size 900 mm × 600 mm) to a depth of 2.0 metre (inside) and 450 mm × 450 mm square shaft (inside measurement) with 250 mm thick 1st class brick work (1:4) in all sides over a layer of jhama brick soling and 150 mm thick Jhama cement concrete (1:4:8) including necessary earth work, invert with ordinary cement concrete (1:2:4) with stone chips over brick-on-edge flooring, plastering inside with 20 mm thick cement plastering (1:4) and neat cement punning, including supplying, fitting and fixing one 450 mm. dia (15 MT) heavy duty RCPC manhole cover of approved make with R.C.C. slab of 100 mm thick with cement concrete (1:1.5:3) with stone chips including necessary reinforcement, shuttering and CI foot steps (4 kg each) (Depth of invert should not less than 1.80 m below G.L.)	Each	24663.00	
	ii) Addition and deduction of rate of special inspection chamber pit as per above item for each addition or reduction in depth of 150 mm. or part thereof.	Each	749.00	

Sl.No.	Description of item	Unit	Rate (Rs.)	Remarks
22	Constructing gully pit to a depth of 1.50m (Inside) with 250mm th. 1st class Brick Work (1:4) in all sides over a layer of jhama brick soling & 100mm th. jhama cement concrete (1:4:8) including necessary earth work, providing approved type C.I. Syphone (225mm dia) with topping RCPC gully grid (15MT load bearing capacity) constructing invert with brick-on-edge, including 20mm th. inside cement plaster (1:4) finished with neat cement punning, at the top 150mm th. R.C.C. slab (1:1.5:3) with stone chips including necessary reinforcement, shuttering as per standard drawing and as directed by E-I-C complete in all respect and removal of surplus earth with all costs of labour and materials. Inside measurement of gully pit, 1100mm × 600mm	Each	23005.00	
23	Constructing catch pit to a depth of 1.0m (Inside) with 250mm th. 1st class Brick Work (1:4) in all sides over a layer of jhama brick soling & 100mm th. jhama cement concrete (1:4:8) including necessary earth work, providing approved type C.I. Syphone (150mm dia) with topping RCPC gully grid (5MT load bearing capacity) constructing invert with brick-on-edge, including 20mm th. inside cement plaster (1:4) finished with neat cement punning, at the top 100mm th. R.C.C. slab (1:1.5:3) with stone chips including necessary reinforcement, shuttering as per standard drawing and as directed by E-I-C complete in all respect and removal of surplus earth with all costs of labour and materials. Inside measurement of catch pit, 600mm × 525mm	Each	12175.00	
24	Construction of manhole with chamber of size as given below as per requirement without shaft with cement brick work (1:4) over 150mm. thick jhama cement conc. (1:4:8) bed over a layer of brick flat soling including providing 150mm. thick R.C.C. slab with ordinary cement concrete (mix 1:1.5:3) with reinforcement as per standard drawing over the chamber, brick on edge flooring with ordinary cement concrete (mix 1:2:4) in the invert with 20mm. thick cement plastering (1:4) finished fine with neat cement 1.50 mm. thick in the inside walls and invert, including supplying, fitting and fixing R.C.P.C. manhole cover & frame (35 M.T. load bearing capacity) with ordinary cement concrete (mix 1:2:4) & C.I. steps (4kg. Each) including cutting hard crust, excavation, dewatering, back filling and			

Schedule of Rates

Sl.No.	Description of item	Unit	Rate (Rs.)	Remarks
	removal of spoils but excluding shoring complete as per standard drawing. (Depth of invert shall be between 1.25 m. and 1.80 m. below G.L.) i) Average depth of invert 1.25 m. below G.L with 250 mm. thick brick work			
	a) 150 mm to 400 mm dia having internal size (1500mm × 750mm)	Each	26898.00	
	b) Above 400 mm to 600 mm dia having internal size (1500mm × 1100mm)	Each	31347.00	
	c) Above 600 mm to 900 mm dia having internal size (1500mm × 1500mm)	Each	35940.00	
	d) Above 900 mm to 1200 mm dia having internal size (1500mm × 1600mm)	Each	36700.00	
	ii) Addition to rate of manhole chamber without shaft as per above item for each addition in depth of 150 mm. or part thereof. With 250 mm. thick brick work.			
	a) 150 mm to 400 mm dia having internal size (1500mm × 750mm)	Each	3228.00	
	b) Above 400 mm to 600 mm dia having internal size (1500mm × 1100mm)	Each	3762.00	
	c) Above 600 mm to 900 mm dia having internal size (1500mm × 1500mm)	Each	4313.00	
	d) Above 900 mm to 1200 mm dia having internal size (1500mm × 1600mm)	Each	4404.00	
25	Construction of manhole with chamber of size as given below as per requirement and 600mm × 600mm. (inside measurement) square shaft, with cement brickwork (1:4) over 150 mm. thick jhama cement concrete (1:4:8) bed, over a layer of brick flat soling including providing 150mm. thick R.C.C. slab with ordinary concrete (mix 1:1.5:3) with reinforcement as per standard drawing over the chamber, brick-on-edge flooring with ordinary cement concrete (mix 1:2:4) in the invert with 20mm. thick cement plaster (1:4) finished fine with 1.5mm. thick neat cement in the inside walls and invert including supplying, fitting and fixing R.C.P.C. cover and frame (35 M.T. load bearing capacity) with ordinary cement concrete (mix 1:2:4) and C.I. steps (4 Kg. each) including cutting hard crust, excavation, de-watering, back filling and removal of spoils but excluding shoring complete as per standard drawing.			

Sl.No.	Description of item	Unit	Rate (Rs.)	Remarks
	(Depth of invert shall not be less than 1.80M below G.L.) Average depth of invert 2.5m. below G.L.			
	i) With 250mm. thick brick work			
	a) 150 mm to 400 mm dia having internal size (1500mm × 750mm)	Each	38129.00	
	b) Above 400 mm to 600 mm dia having internal size (1500mm × 1100mm)	Each	43548.00	
	c) Above 600 mm to 900 mm dia having internal size (1500mm × 1500mm)	Each	49004.00	
	d) Above 900 mm to 1200 mm dia having internal size (1500mm × 1600mm)	Each	49231.00	
	ii) Addition or reduction to rate of manhole as per above item for each addition or reduction in depth of 150 mm. or part thereof. With 250mm. thick brick work (Depth of invert should not exceed 3.00M.)			
	a) 150 mm to 400 mm dia having internal size (1500mm × 750mm)	Each	947.00	
	b) Above 400 mm to 600 mm dia having internal size (1500mm × 1100mm)	Each	978.00	
	c) Above 600 mm to 900 mm dia having internal size (1500mm × 1500mm)	Each	1241.00	
	d) Above 900 mm to 1200 mm dia having internal size (1500mm × 1600mm)	Each	1455.00	
	iii) Average depth of invert 2.5m. below G.L With 375 mm. thick brick work			
	a) 150 mm to 400 mm dia having internal size (1500mm × 750mm)	Each	51086.00	
	b) Above 400 mm to 600 mm dia having internal size (1500mm × 1100mm)	Each	57264.00	
	c) Above 600 mm to 900 mm dia having internal size (1500mm × 1500mm)	Each	63841.00	
	d) Above 900 mm to 1200 mm dia having internal size (1500mm × 1600mm)	Each	63208.00	
	iv) Addition or reduction to rate of manhole as per above item for each addition or reduction in depth of 150 mm. or part thereof. With 375 mm. thick brickwork (Depth of invert should not exceed 3.00M.)			
	a) 150 mm to 400 mm dia having internal size (1500mm × 750mm)	Each	1511.00	
	b) Above 400 mm to 600 mm dia having internal size (1500mm × 1100mm)	Each	1664.00	
	c) Above 600 mm to 900 mm dia having internal size (1500mm × 1500mm)	Each	1813.00	
	d) Above 900 mm to 1200 mm dia having internal size (1500mm × 1600mm)	Each	2027.00	

Cost of Class NP-2 R.C.C. Spun Pipes

Bore dia in mm.	Thickness in mm.	Standard length in m.	Rate for each pipe including Loading, Unloading & Freight Charges (Rs.)	Rate for each collar including Loading, Unloading & Freight Charges (Rs.)
150	25	2.0	923.00	154.00
200	25	2.0	1001.00	174.00
225	25	2.0	1131.00	196.00
250	25	2.0	1252.00	240.00
300	30	2.5	1865.00	295.00
450	35	2.5	2965.00	405.00
600	45	2.5	4370.00	605.00
750	50	2.5	6129.00	823.00
900	55	2.5	7442.00	1045.00

**COST OF SPIGOT / SOCKET TYPE OF PIPE WITH RUBBER GASKET
CLASS - NP₃**

Bore dia in mm.	Thickness in mm.	Standard length in m.	Rate for each pipe including Loading, Unloading & Freight Charges (Rs.)
150	25	2.0	1046.00
200	30	2.0	1145.00
225	30	2.0	1272.00
250	30	2.0	1451.00
300	40	2.5	2242.00
400	75	2.5	4604.00
450	75	2.5	5022.00
500	75	2.5	5962.00
600	85	2.5	7896.00
700	85	2.5	9584.00
800	95	2.5	11162.00
900	100	2.5	13298.00
1000	115	2.5	14792.00
1100	115	2.5	16771.00
1200	120	2.5	18748.00
1400	135	2.5	25325.00
1600	140	2.5	32199.00
1800	150	2.5	38236.00
2000	170	2.5	47862.00

Note : The above rates are inclusive of all charges including Contractor's profit, but exclusive of GST.

STANDARD DRAWINGS

STANDARD CROSS SECTION OF R.C.C PIPE SEWER WITH CONTINUOUS CONCRETE CRADLE BEDDING

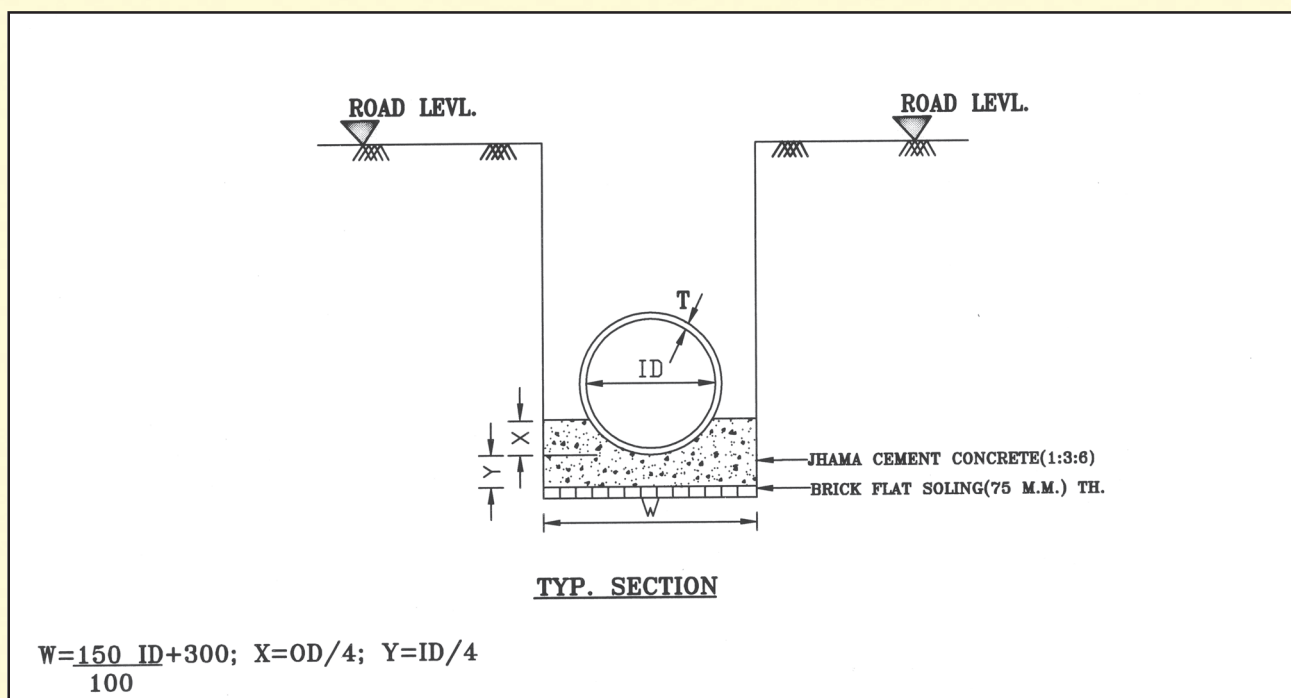

CLASS NP2 PIPE						CLASS NP3 PIPE					
ID (M.M.)	T (M.M.)	W (M.M.)	X (M.M.)	Y (M.M.)	VOL. OF CONC./ M.(Cum.)	ID (M.M.)	T (M.M.)	W (M.M.)	X (M.M.)	Y (M.M.)	VOL. OF CONC./ M.(Cum.)
150	25	525	50	40	0.041	150	30	525	50	40	0.041
200	25	600	65	50	0.059	200	30	600	65	50	0.059
225	25	640	70	60	0.071	225	30	640	70	60	0.071
250	25	675	80	65	0.082	250	30	675	80	65	0.082
300	30	750	90	75	0.104	300	40	750	95	75	0.105
375	32	865	110	95	0.148	350	75	865	125	90	0.139
400	32	900	120	100	0.163	400	75	900	140	100	0.168
450	35	975	130	115	0.197	450	75	975	150	115	0.203
500	35	1050	145	125	0.232	500	75	1050	160	125	0.234
600	45	1200	170	150	0.312	600	85	1200	190	150	0.319
700	50	1350	200	175	0.407	700	85	1350	220	175	0.415
750	50	1425	210	190	0.461	750	85	1425	230	190	0.468
800	50	1500	225	200	0.513	800	95	1500	250	200	0.522
900	55	1650	250	225	0.629	900	100	1650	275	225	0.639
1000	60	1800	280	250	0.761	1000	115	1800	310	250	0.773
1100	65	1950	310	275	0.905	1100	115	1950	330	275	0.911
1200	70	2100	335	300	1.058	1200	120	2100	360	300	1.068
1400	75	2400	390	350	1.403	1400	135	2400	420	350	1.416
1500	75	2550	410	375	1.587	1500	135	2550	440	375	1.601
1600	80	2700	440	400	1.792	1600	140	2700	470	400	1.806
1800	90	3000	495	450	2.233	1800	150	3000	525	450	2.247
2000	100	3300	550	500	2.722	2000	170	3300	585	500	2.739

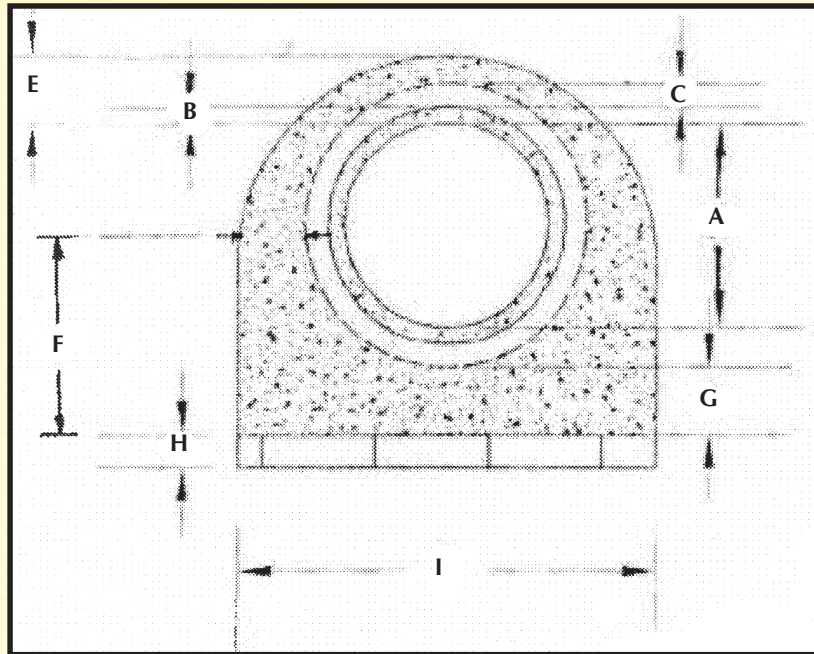

A (mm)	B (mm)	C (mm)	D (mm)	E (mm)	F (mm)	G (mm)	H (mm)	I (mm)	VOL. OF CONC/m cu.m.
100	12	22	200	75	162	100	75	524	0.112
150	16	28	200	75	241	150	75	582	0.157
225	22	35	200	76	265	150	75	659	0.220
250	22	35	200	76	297	150	75	694	0.232
300	25	37	200	76	325	150	75	750	0.262
375	31	45	200	100	369	150	75	837	0.329
450	37	50	200	100	412	150	75	924	0.379

UD & MA SOR 2018.

TYPICAL DRAWING OF MANHOLE WITH SHAFT.

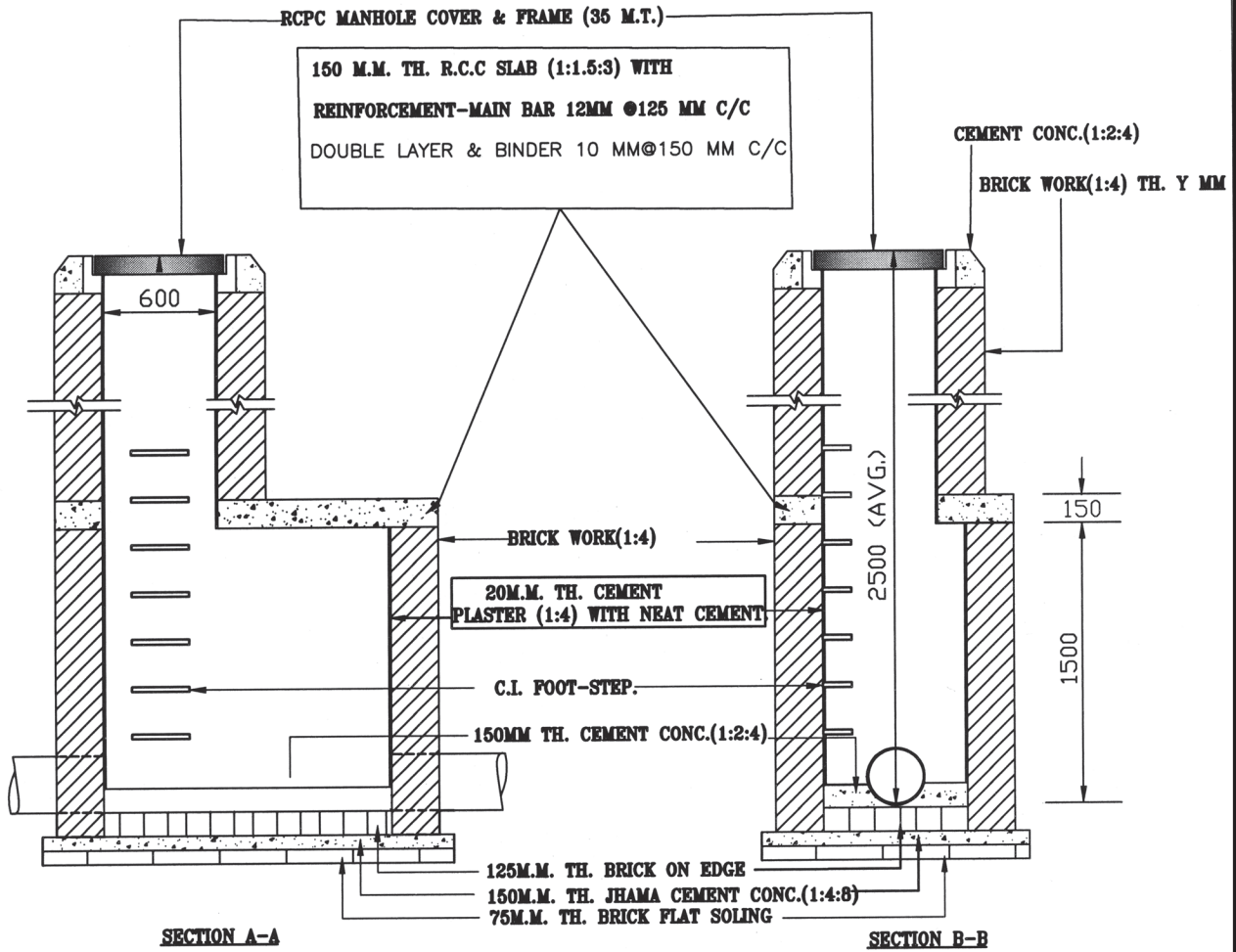

SL. NO	DIA OF PIPE IN MM	INTERNAL SIZE IN MM (1500xX)
1	150 TO 400	1500X750
2	>400 TO 600	1500X1100
3	>600 TO 900	1500X1500
4	>900 TO 1200	1500X1600

Y=250 OR 375 MM

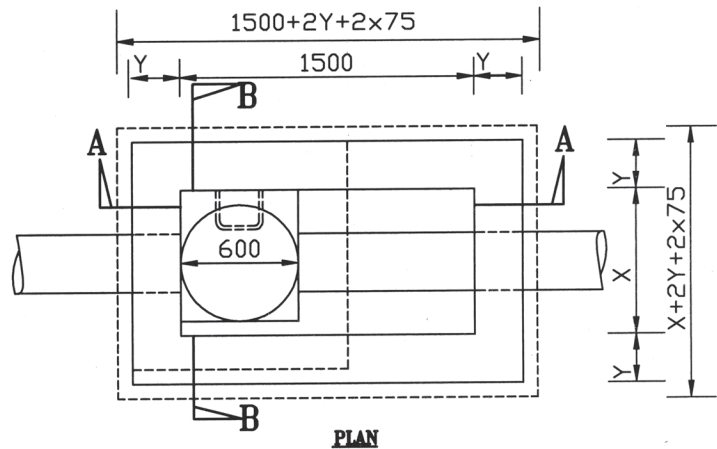

ALL DIMENSIONS ARE IN M.M. DRAWING NOT TO SCALE

UD & MA SOR 2018.

TYPICAL DRAWING OF MANHOLE WITHOUT SHAFT.

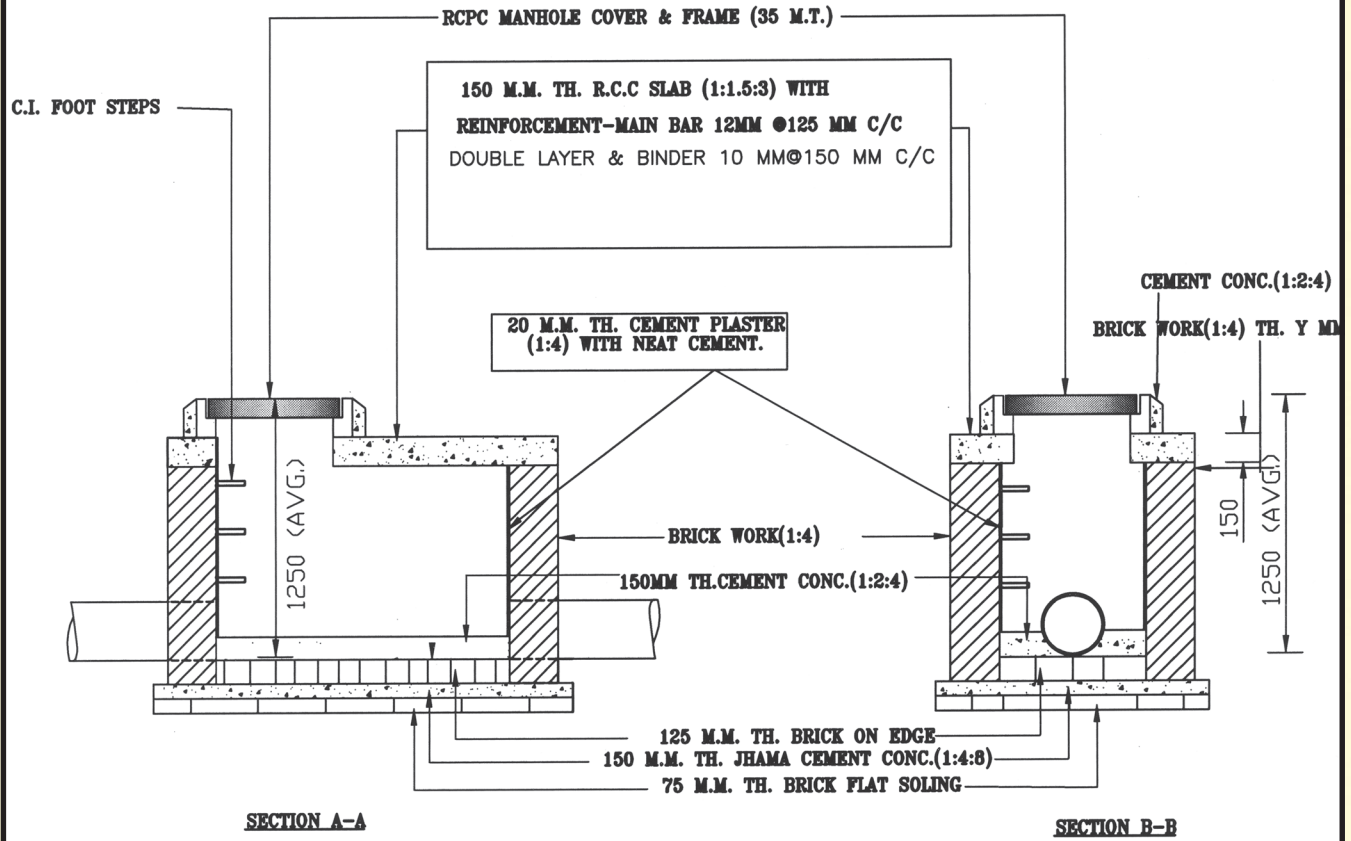

SL. NO	DIA OF PIPE IN MM	INTERNAL SIZE IN MM (1500xX)
1	150 TO 400	1500X750
2	>400 TO 600	1500X1100
3	>600 TO 900	1500X1500
4	>900 TO 1200	1500X1600

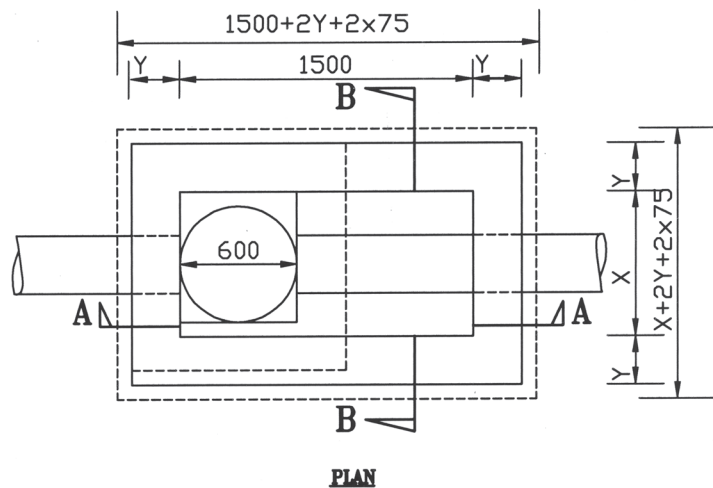

Y=250 OR 375 MM

ALL DIMENSIONS ARE IN M.M. DRAWING NOT TO SCALE

UD & MA SOR 2018.

STANDARD DRAWING OF MANHOLE WITHOUT SHAFT.

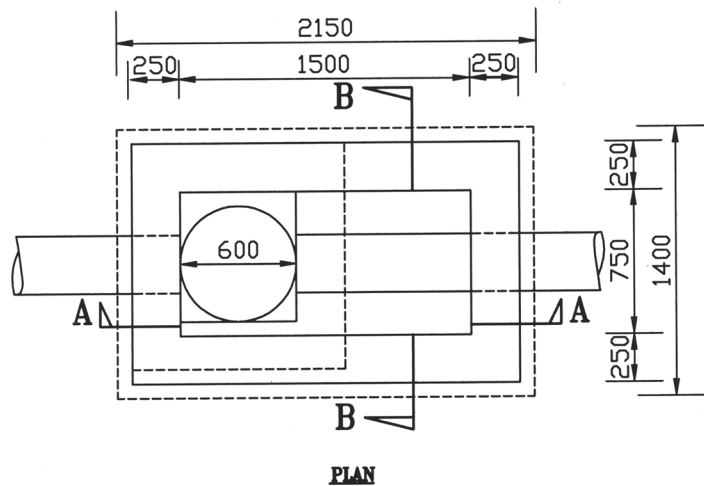
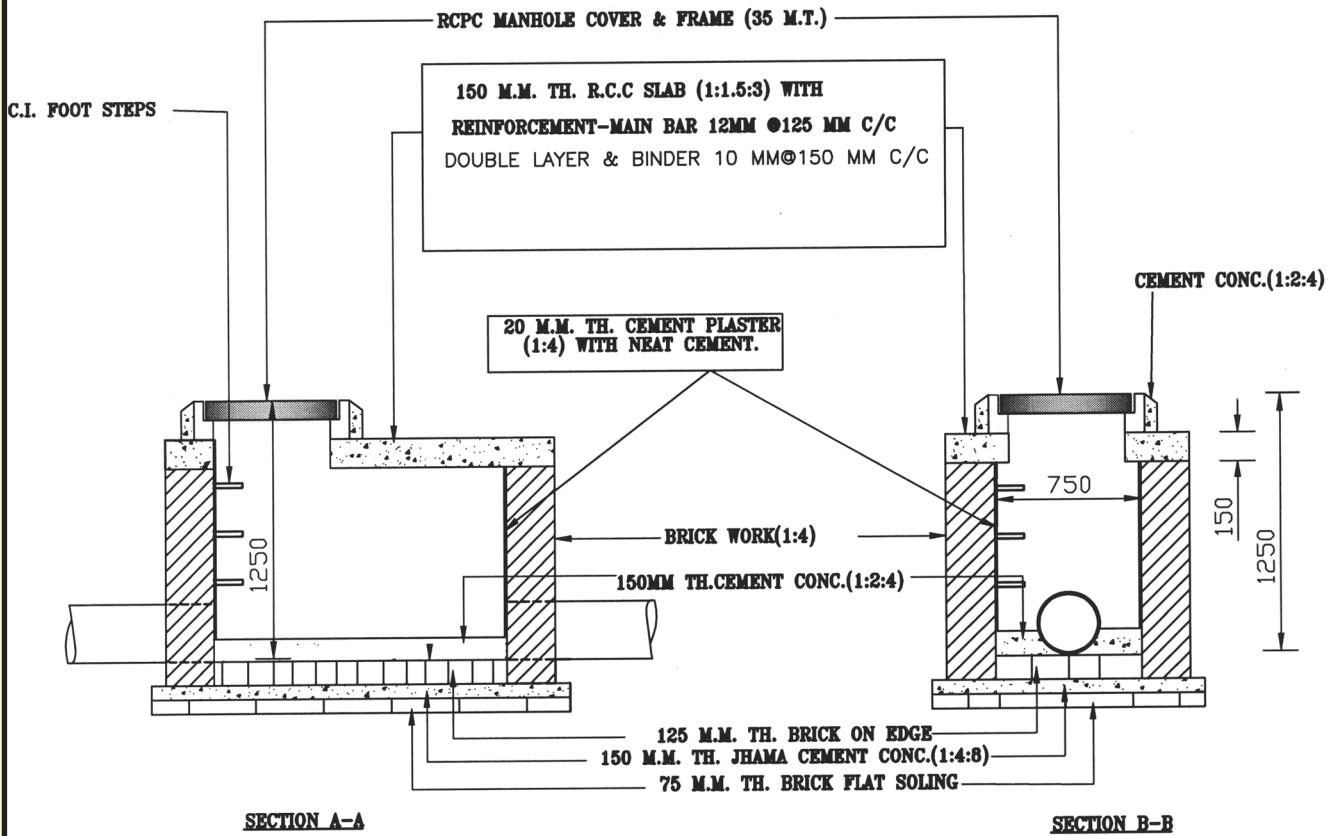

ALL DIMENSIONS ARE IN M.M. DRAWING NOT TO SCALE

UD & MA SOR 2018.

STANDARD DRAWING OF SPECIAL INSPECTION CHAMBER PIT WITHOUT SHAFT.

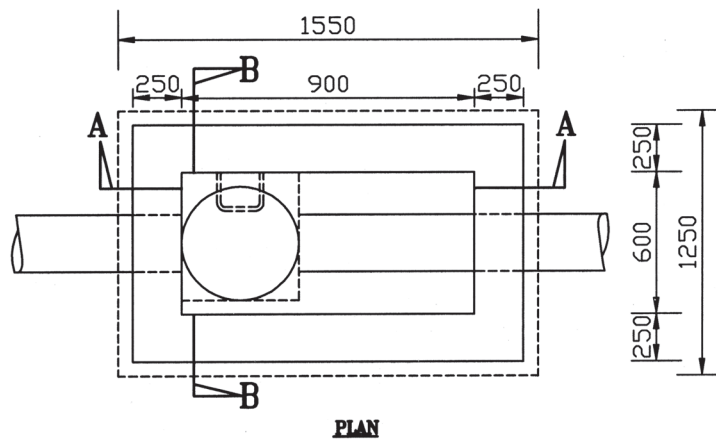
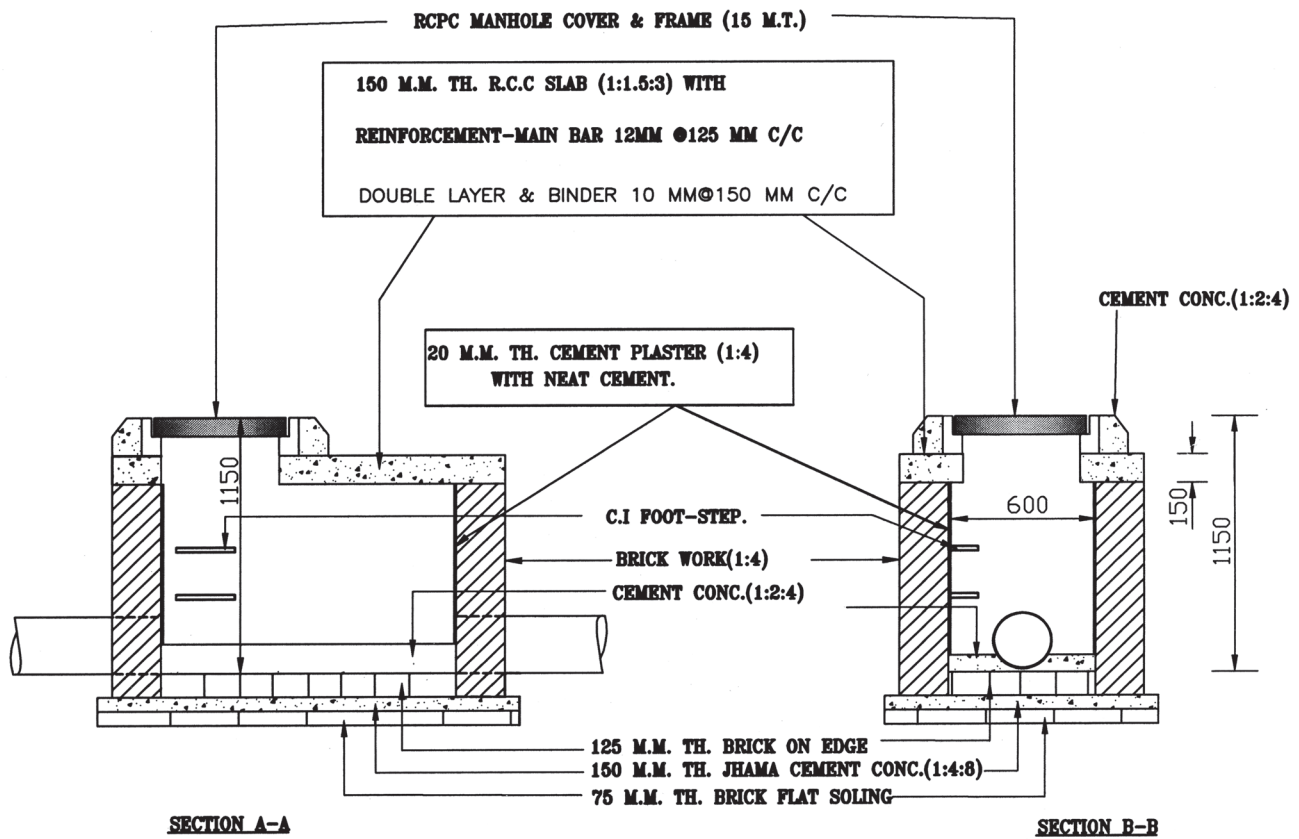

ALL DIMENSIONS ARE IN M.M. DRAWING NOT TO SCALE

UD & MA SOR 2018.

STANDARD DRAWING OF SPECIAL INSPECTION CHAMBER PIT WITH SHAFT.

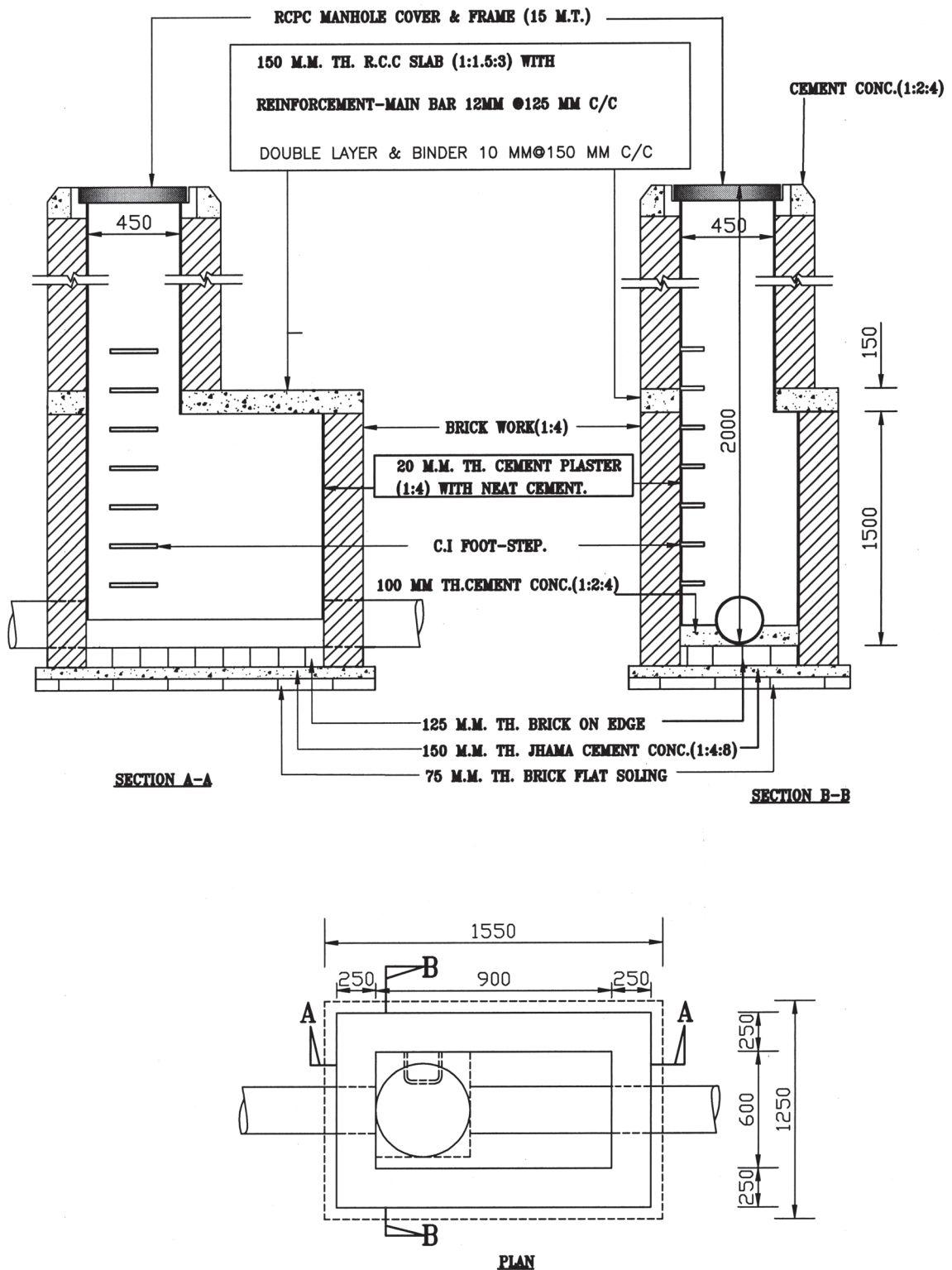

ALL DIMENSIONS ARE IN M.M. DRAWING NOT TO SCALE

UD & MA SOR 2018.

STANDARD DRAWING OF GULLYPIT.

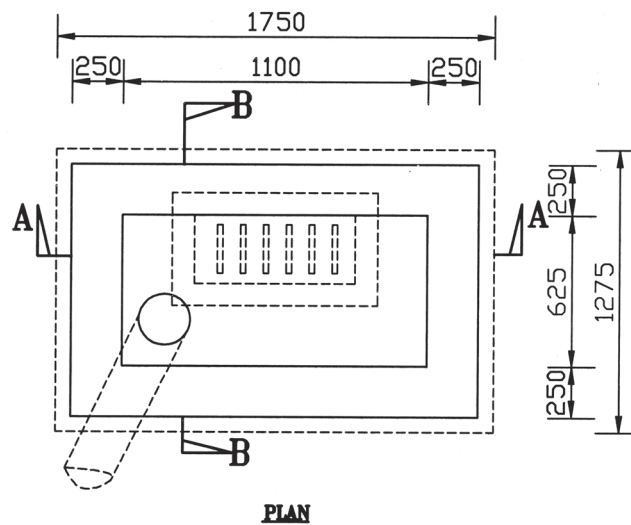
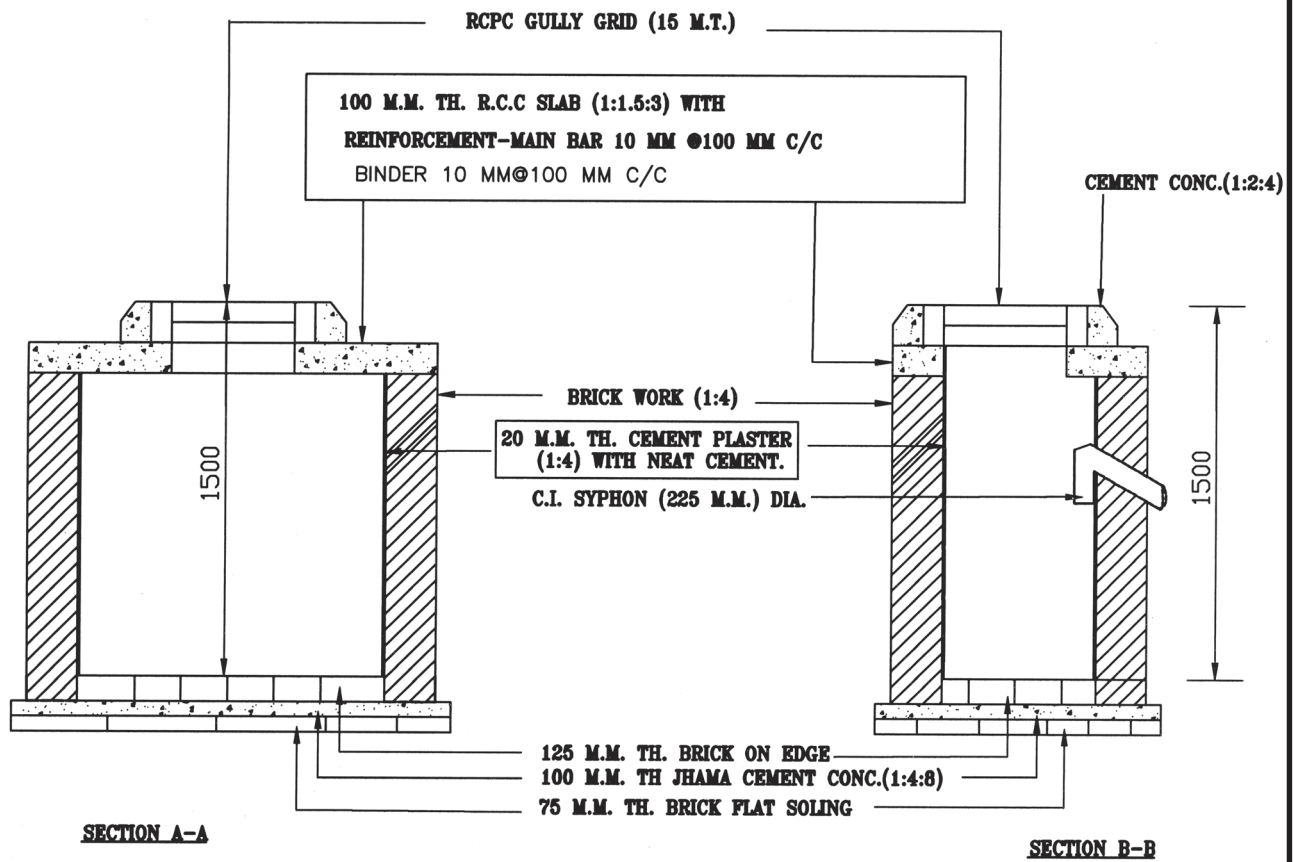

ALL DIMENSIONS ARE IN M.M. DRAWING NOT TO SCALE

UD & MA SOR 2018.

STANDARD DRAWING OF CATCH PIT.

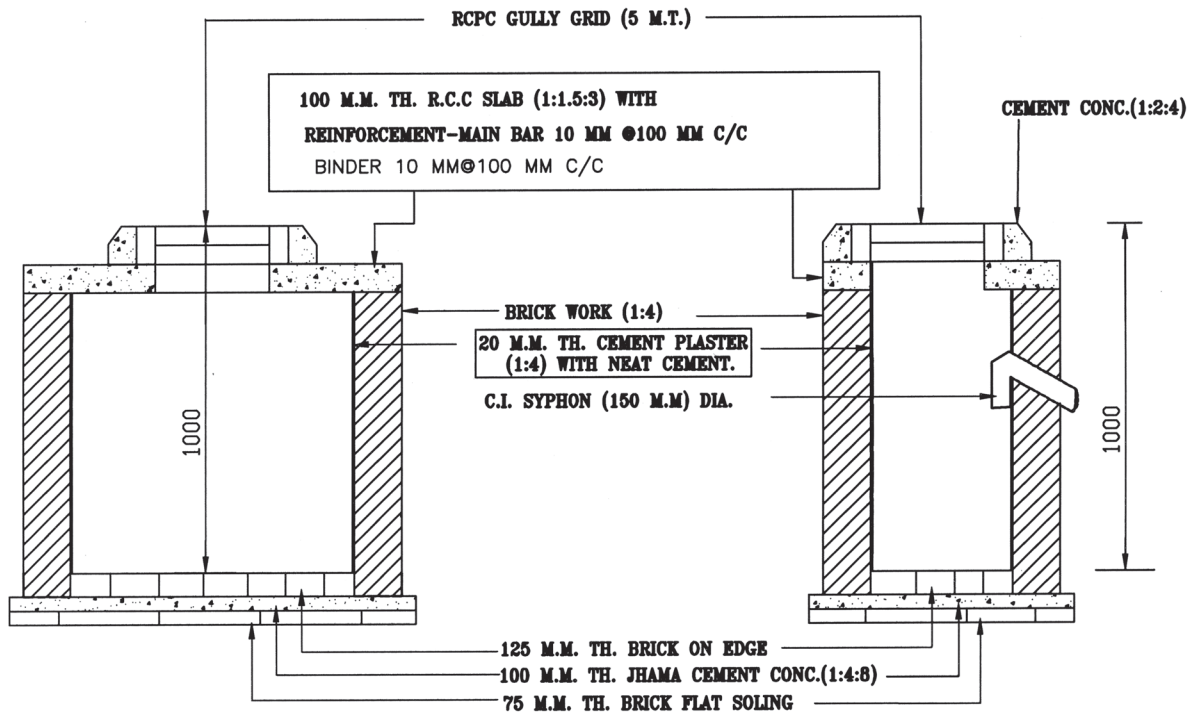

SECTION A-A

SECTION B-B

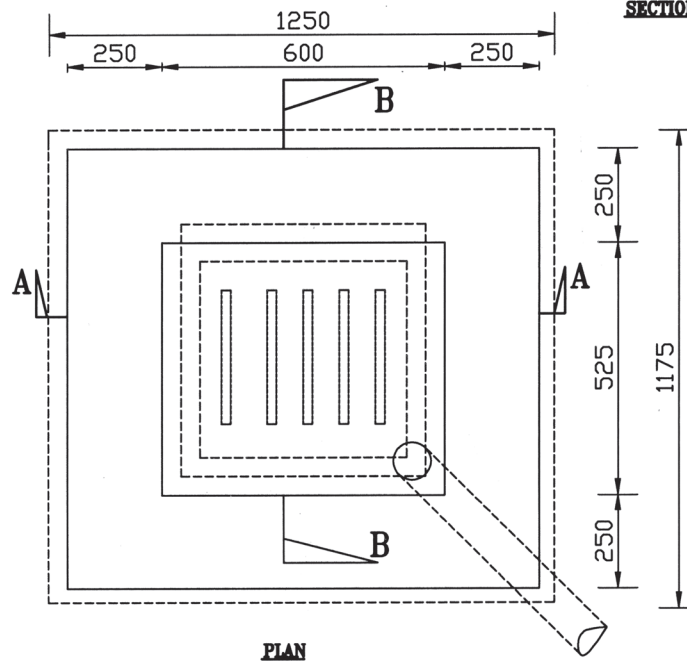

ALL DIMENSIONS ARE IN M.M. DRAWING NOT TO SCALE



Printed at
Saraswati Press Limited
(Government of West Bengal Enterprise)