

# Office of the Burdwan Municipality

G.T. Road, Burdwan, West Bengal, India – 713101 Phone: +91 0342  
2662518 / 2664121 / 2662777 | Fax: +91 0342 2560717 Email:  
info@burdwanmunicipality.gov.in | Website: www.  
burdwanmunicipality.gov.in

MEMONO. 54/E/XII-4/AMRUT

DATED: 17/06/2020

## NOTICE INVITING ELECTRONICTENDER No. 2 Tender Ref: No. WBMAD/BM/AMRUT/2/19-20 (5th call)

The Administrator, Burdwan Municipality, invites sealed competitive Bid on Turnkey Basis (Two part System) from reliable and resourceful Companies / Firms / Contractors having experience and acumen in construction work as noted .The eligibility are depicted hereunder for participating in the e-Bid.

### **1) Name of the Work :-**

Survey, Planning, Design, Construction, Erection,Supply, Delivery,Fitting & Fixing of all necessary equipments,Commissioning and Completion in all respect of Civil and Electro- Mechanical Works including all others allied, related works for enabling 2 nos.of 22.73 MLD Capacity each Radial Collector Wells with laying of stainless steel strainer pipes by jack pushing method & designing operation along with Pump House, Access & Pipe carrying Bridge at Damodar including HT Sub Station Building at Damodar River in between Belkash & Zuzuty village, protection work at river bank, Raw Water Rising Main including construction of Pipe carrying Bridge on Banka & DVC Canal & laying of Raw water Rising main from Zujhuti to JalkalMath at Lakuddi for Conveying raw water & Parmanent Road restoration works from Radial Collector Wells to WTP as recommended in the Hydro- geological investigation report of Jadavpur University along with all manifold line and necessary valves and accessories, and construction of boundary wall, approach road, drain at Sub-station area with necessary Civil, Electrical (according to Indian Electricity rules), Mechanical & all other allied works related for pump house with necessary approval from respective Competent Authority including lightening within yard, pump house, walkway and internal illumination complete in all respect on turnkey basis as per satisfaction of the department. After satisfactory completion and commissioning, 3 (three) months trial run, necessary training of maintenance staff & thereafter (subsequently) 5 (five) years operation and maintenance with security /guarding arrangement under AMRUT Project.

**Note :** Necessary soil test & Hydro geological investigation and study of sub surface water flow/storage characteristics of river Danmodar should be done by the Bidder.

Department may conduct a soil test and Hydro- geological investigation separately in that conservative criteria of soil test & Hydro- geological investigation shall be considered all the design parameter among these two shall be considered.

**2) Location of Work:- 2 NOS. Radial collector wells in between Belkash & Zuzuty village (as recommended in Hydro- geological investigation report of Jadavpur University), Damodar River, Burdwan, District Purba Bardhaman and location of WTP at Lakuddi Jalkal, Burdwan Municipality, District Purba Bardhaman.**

**3) Eligibility to participate in the Bid:**

<b>Having and Construction of H.T. Substation ng experience and technical acumen in execution, Construction and Completion of Intake well and Construction of H.T. Substation / radial Collector well and Construction of H.T. Substation / Infiltration Gallery and Construction of H.T. Substation of capacity 15 MLD at least including Civil &amp; Electro Mechanical works, Substation at least in a single / separate contract during last five financial years in any Govt. / Board / Semi Govt. / Municipal Corporation / Statutory Authority /Govt. undertaking etc. organization.</b>
<b>AND</b>
<b>Having sufficient qualified technical personnel (to be employed under the firm for at least 2 consecutive years) with sound knowledge and experience in execution of similar type of works.</b>
<b>AND</b>
<b>Having annual turnover from bank or from balance sheet duly verified by Chartered Accounted of at least Rs. 4.00 crore or above in any one year of last five financial years.</b>
<b>AND</b>
<b>Having valid and electrical HT license of supervisor (to be employed under the firm for at least 2 consecutive years), GST registration certificate, PAN CARD, IT return of three years ESI and P.F. registration certificate.</b>
<b>AND</b>
<b>Bank solvency Certificate not less than 2.00 <b>Creore in</b> the last (i.e. 2017-2018)/2018-2019 financial year.</b>
<b>AND</b>
<b>Particular of ownership /partnership or board of directors pertaining to the organization /company / firm.</b>
<b>AND</b>
<b>List of machineries &amp; equipment necessary for fields and list of technical personal employed under the organization in details with name, qualification, experience and address with contact number.</b>
<b>AND</b>
<b>Corresponding address, fax &amp; telephone numbers, contract mobile number and email number of the organization.</b>

#### **4) Documents to be produced in support of Credential for Bid:-**

A successful performance and completion certificate supplemented with work order along with payment certificate issued by the competent authority, shall have to be furnished in support of credibility in terms with eligibility criteria depicted in this Notice (**Ref: Sl. No. 3 : Eligibility to participate in the Bid**). Besides this, following documents shall have to be furnished:

- a) Particulars of ownership / partnership or Board of Directors pertaining to the Organization / Company / Firm.
- b) Copies of valid GST certificate, **Relevant Electrical Supervisory** license Certificate (HT & LT).
- c) Bank solvency Certificate not less than 2.00 crores in the last financial year 2017-2018 or 2018-19.
- d) Valid documents in support of annual Turnover.
- e) **Credential certificate of similar nature job of minimum One Crore in the last 10 financial years.**
- f) List of machines & equipment necessary for fields.
- g) List of Technical Personnel employed under the organization in details with names, qualification, experience and address with contact number.
- h) Corresponding address, fax & telephone nos. Contract mobile no. & Email no. of the Organization.

**All documents in original to be produced in due course of time as & when asked by the Tender Inviting Authority**

#### **5) Earnest Money:-**

- a) **2% of the Quoted Bid price in two parts, vice. Rs. 5,00,000.00 (Rupees Five Lakhs only) as an initial Earnest Money with Bid Proposal and rest as mentioned below.**
- b) **Initial earnest money is to be deposited either online by net Banking through using ICICI Bank Payment Gateway or offline through RTGS / NEFT. Please refer Memo No 3975-F(Y) dated 28.07.2016 of the Finance Department, Govt. of West Bengal**
- c) **Earnest Money Deposit i.e. 2% of bid amount beyond Rs. 5,00,000.00 (if any) shall have to be deposited after acceptance of Bid Proposal in the form of Bank Draft from any nationalized/scheduled Bank in favour of “Burdwan Municipality”, Payable at Burdwan.**

**6) Date and time schedule:-**

Sl. No.	Particulars	Date & Time
1	Date of uploading of NleB. and Bid Documents (online) (Publishing Date)	19/06/2020 at 11:00 A.M
2	Date of Pre Bid Meeting with the intending bidders In the office of the Superintending Engineer, M.E.Dte., West Circle Patal Bazar, 3 <sup>rd</sup> fl. Tinkonia, Purba Burdwan, Pin- 713101, Email- sewcmed@gmail.com	01/07/2020 at 03:00 P.M
3	Documents download start date (Online)	19/06/2020 at 02:00 P.M
4	Documents download end date (Online)	17/07/2020 at 03:00 P.M
5	Bid submission start date (On line)	19/06/2020 at 03:00 P.M
6	Bid Submission closing (On line)	17/07/2020 at 06:00 P.M
7	Tentative Bid opening date for Technical Proposals (Online)	20/07/2020 at 11:00 A.M
8	Date of uploading list for Technically Qualified Bidder (online)	To be notified later
9	Date for opening of Financial Proposal (Online)	To be notified later
10	Also if necessary for further negotiation through off line for final rate.	To be notified later

**7) Cost price of Bid Document:-**“Nil”

**8) Time of completion:-**

Time of completion of the Contract is 16(sixteen) months from the date of issue of Work Order.

**9) Site inspection & general information:-**

Intending Bidders are required to inspect the site of the Project with particular reference to location and infrastructure facilities. They are to make a careful study of all relevant data with regard to availability of Sufficient Quantum of Water as per the Requirement for the project and all relevant factors as might affect the rates and prices. They should make themselves acquainted with the relevant IS specifications, CPHEEO manuals, Clauses & Sub Clauses of the Bid documents and to have fully acquainted with all details of work front, communications, underground utility services, seasonal weather and its variation including High Flood level, labour, water supply, existing & proposed site levels, position and diversion of transportation and barricading , if required, electricity and any other general information including topological condition & existing level which are needed for the work to be completed in scheduled time properly.

## 10) **Bid documents:-**

A full set of Bid documents consists of 2 Parts. These are;

a) **Part I** containing all documents in relation to the name of the firm applied credentials possessed by them, all documents as depicted in Sl. No. 4 along with this NleB and its all corrigenda's.

AND

Section A: BID NOTICE, CORRIGENDUM AND ADDENDUM (to be inserted).

Section B: DECLARATION BY THE BIDDER.

Section C: PROJECT BACKGROUND WITH SALIENT INFORMATION

Section D: SCOPE OF WORK

Section E: SCHEDULE OF WORK

Section F: PROCESS DESCRIPTION AND DESIGN PARAMETERS

Section G: Survey, Planning, Design, Construction, Erection, Supply, Delivery, Fitting & Fixing of all necessary equipments, Commissioning and Completion in all respect of Civil and Electro- Mechanical Works including all others allied, related works for enabling 2 nos. of 22.73 MLD Capacity each Radial Collector Wells with laying of stainless steel strainer pipes by jack pushing method & designing operation along with Pump House, Access & Pipe carrying Bridge at Damodar including HT Sub Station Building at Damodar River in between Belkash & Zuzuty village, protection work at river bank, Raw Water Rising Main including construction of Pipe carrying Bridge on Banka & DVC Canal & laying of Raw water Rising main from Zujhuti to Jalkal Math at Lakuddi for Conveying raw water & Permanent Road restoration works from Radial Collector Wells to WTP as recommended in the Hydro- geological investigation report of Jadavpur University along with all manifold line and necessary valves and accessories, and construction of boundary wall, approach road, drain at Sub-station area with necessary Civil, Electrical (according to Indian Electricity rules), Mechanical & all other allied works related for pump house with necessary approval from respective Competent Authority including lightening within yard, pump house, walkway and internal illumination complete in all respect on turnkey basis as per satisfaction of the department. After satisfactory completion and commissioning, 3 (three) months trial run, necessary training of maintenance staff & thereafter (subsequently) 5 (five) years operation and maintenance with security /guarding arrangement under AMRUT Project.

Section H: All drawings, designs should be vetted by the premier Institutions like, NITs/IITs/Jadavpur University and the Chief Engineer / the Superintending Engineer (E/M), KMDA. as per current related IS Codes and same should be submitted in 6 (six) copies for necessary approval of Superintending Engineer, M.E. Dte (West Circle).

Section I: All the works required as per CPHEEO Manual or relevant code to draw 45.47 MLD is within the scope of bidder.

Section J: Laying of M.S. Rising Main on foot Way Bridge

Section K: Boundary wall

- i. List of documents to be furnished
- ii. Tentative Layout of Substation Building
- iii. List of tools / Electrical equipment.
- iv. List of vendors
- v. List of deviation
- vi. Tentative lay out plan of Intake Jetty
- vii. Site Plan

Section L: Terms of Payment

b) **Part II** containing following documents; Bid Price / Price Schedule (BOQ) **in separate part of Civil Work and Electromechanical Work, respectively.**

**11) Validity of Bid:-**

A Bid submitted shall remain valid for a period of 240 calendar days from the date set for opening of Bids. Any extension of this validity period if required will be subject to concurrence of the Bidders.

**12) Withdrawal of Bid:-**

A Bid once submitted shall not be withdrawn within the validity period. If any Bidder/Bidders withdraw his / their Bid(s) within the validity period then Earnest Money as deposited by him / them will be forfeited.

**13) Acceptance of Bid:-**

The Chairman/ Administrator, Burdwan Municipality will accept the Bid on recommendation of the Competent Authority. He does not bind himself to accept otherwise the lowest Bid and reserves to himself/herself the right to reject any or all of the Bids received without assigning any reason thereof.

**14) Intimation:-**

The successful Bidder will be notified in writing of the acceptance of his Bid. The Bidder then becomes the "Contractor" and he shall forthwith take steps to execute Formal Contract Agreement with The Chairman/ Administrator, Burdwan Municipality in 4 (four) copies after depositing requisite cost of Formal Contract Agreement and fulfil all his obligations as required by the Contract.

After the Bid is provisionally accepted, the Bidder shall submit detail Design, Drawing and working specifications phase wise based on existing site condition & proposed levels at site. It will be approved by the Superintending Engineer (West Circle) if it is found technically correct and acceptable

with proper examination by the Superintending Engineer (West Circle), M.E. Dte. & the Chief Engineer / Superintending Engineer, (E/M), K.M.D.A. Provisional approval of the submitted drawings will be accorded phase wise for execution. Eventually, all the parts, Design, Drawings etc. of the successful Bidder shall be taken as a part of the agreement.

**15) Escalation of Cost:-**

There will be no escalation in cost for materials or labour and the contract price mentioned in the contract stands valid till completion of the operation and maintenance of the contract.

**16) Name & address of Engineer-In-Charge (EIC) of the Work**

For Civil Work, Executive Engineer, Burdwan Division, M.E.Dte. and For Electro Mechanical Work Executive Engineer (E/M) K.M.D.A.

**17) Execution of Work:-**

The Contractor is liable to execute the whole work as per direction and instruction of the Executive Engineer, Burdwan Division, M.E.Dte. and for Electro Mechanical Work Executive Engineer (E/M) K.M.D.A. upto the satisfaction of E-I-C or his/her representative.

**18) Payment:-**

Payment will be made to the successful Bidder by The Chairman/Administrator, Burdwan Municipality periodically only on receipt of written recommendation from the Executive Engineer, Burdwan Division, M.E.Dte. and for Electro Mechanical Work Executive Engineer (E/M) K.M.D.A & after satisfaction of E-I-C or his/her representative.

**19) Influence:-**

Any attempt to exercise undue influence in the matter of acceptance of Bid is strictly prohibited and any Bidder who resorts to this will render his Bid liable to rejection.

**Following clauses are to be adhering to by the concerned Bidder during the process of Bidding.**

20.	In case office faces sudden closure owing to reason beyond the scope and control of The Chairman/Admistrator, any of last date / dates as schedule in Sl. No 7 may be extended up-to / to next and following working day without issuing further and separate notice should The Chairman/Admistrator feel it to be necessary and exigent.
21.	Persons having authenticated and having registered Power of Attorney may be considered lawfully becoming to be acting on and for behalf of the Bidder.
22.	Sufficient care has been taken to avoid variance in between the contents of the listed documents in the Bid documents. However, if there is any variance between the contents of different documents, the provision of documents appearing earlier in the list shall prevail over the same provided in the contents coming later.
23.	Imposition of any duty / tax / rule etc. owing to change / application in legislations / enactment shall be considered as a part of the contract and to be adhering to by the Bidder / contractor strictly.
24.	Bid Acceptance Authority is The Chairman/Administrator Burdwan Municipality.
25.	In case of any dispute arising from any clauses of similar nature between bid documents and Municipal tender form, the recomendation of the Superintending Engineer (West Circle) and Superintending Engineer, KMDA (E/M) will be final and binding.
26.	All usual deductions for GST, IT, and Labour welfare Cess etc. as applicable will be made from the bills from time to time which is inclusive in cl.57 of section C.
27.	No conditional / incomplete Bid shall be entertained.
28.	In the event of e-Filing intending bidder may download the tender document from the website <a href="https://wbtenders.gov.in">https://wbtenders.gov.in</a> directly by the help of Digital Signature Certificate free of cost. Technical Bid & FinancialBid both will be submitted concurrently duly digitally signed in the Website <a href="https://wbtenders.gov.in">https://wbtenders.gov.in</a> . Tender document may be downloaded from website & submission of Technical Bid/Financial Bid as per Tender Schedule.
29.	The requisite cost of Earnest Money, as specified in this NleB shall be paid to ICICI bank by online internet bank transfer or NEFT or RTGS in favour of Burdwan Municipality (as per GO No. 3975-F(Y) dt. 28.07.2016 of Finance Department, Govt. of West Bengal). Every such Transfer shall be done on or after the date of publish of NleB. Any Bid without such Transfer of EM (Except exemption as per G.O.) shall be treated as informal and shall be automatically cancelled. Online transfer of Earnest Money receipt (Scanned copy) shall be uploaded as statutory document.
30.	The Bidder, at the Bidder's own responsibility and risk is encouraged to visit and examine the site of works and its Surroundings and obtain all information that may be necessary for preparing the Bid and entering into a contract for the work as mentioned in the Notice inviting Tender, the cost of visiting the site shall be at the Bidder's own expense. Traffic management and execution shall be the responsibility of the Agency at his / her / their risk and cost.



31.	The intending Bidders shall clearly understand that whatever may be the outcome of the present invitation of Bids, no cost of Bidding shall be reimbursable by the Municipality. The Chairman/Administrator Burdwan Municipality reserves the right to reject any application for purchasing Bid documents and to accept or reject any or all the offered bid / bids without assigning any reason whatsoever and is not liable for any cost that might have incurred by any Bidder at any stage of Bidding.
32.	Prospective applicants are advised to note carefully the minimum qualification criteria as mentioned in 'Instructions to Bidders' before bidding.
33.	During scrutiny, if it is come to the notice to tender inviting authority that the credential or any other papers found incorrect / manufactured / fabricated, that Bidder will not be allowed to participate in the tender and that application will be out rightly rejected without any prejudice.
34.	Before issuance of the work order, the tender inviting authority may verify the credential & other documents with the original of the lowest bidder if found necessary. After verification, if it is found that such documents submitted by the lowest bidder is either manufactured or false, in that case, L.O.A. / work order will not be issued in favour of the bidder under any circumstances.
35.	If any discrepancy arises between two similar clauses on different notifications, the clause as stated in later notification will supersede former one in following sequence: i) Formal Contract Agreement ii) NleB iii) Special terms & Condition iv) Technical bid v) Financial bid
36.	Contractor shall have to comply with the provisions of (a) the contract labour (Regulation Abolition) Act. 1970 (b) Apprentice Act. 1961 and (c) minimum wages Act. 1948 of the notification thereof or any other laws relating thereto and the rules made and order issued there under from time to time.
37.	Where an individual person holds a digital certificate in his own name duly issued to him against the company or the firm of which he happens to be a director or partner, such individual person shall, while uploading any tender for and on behalf of such company or firm, invariably upload a copy of registered power of attorney showing clear authorization in his favour, by the rest of the directors of such company or the partners of such firm, to upload such tender. The power of attorney shall have to be registered in accordance with the provisions of the Registration Act, 1908.
38.	Any legal matter will be settled within the jurisdiction of Hon'ble District Judges Court at Burdwan, Dist:- Purba Bardhaman, West Bengal.
39.	Bidder would be at liberty to point out any ambiguities, contradictions, omissions etc. seeking clarifications thereof or interpretation of any of the conditions of the Bid documents before the Bid Inviting Authority in writing 48 hours prior to Pre Bid Meeting, beyond such period no representation in that behalf will be entertained by the Bid Inviting Authority.
40.	The successful Bidder will remain liable for following with West Bengal Contract Labour (Regulation & Abolition) Act 1970 and necessary certificates from appropriate authority to be submitted within 07 (seven) days from the date of issue of work order, otherwise the work order may be cancelled.

41.	<p>Security Deposit @ 8% (eight percent) will be deducted from each and every running bill. The Security Deposit excluding operation and maintenance will be refunded as per PWD order No. 5784-PW/L&amp;A/2M-175/2017 Dated: 12.09.2017, wherein, Construction of new building / new bridge / new culvert, the Defect Liability Period of the work shall be five years from the actual date of completion of the work;</p> <p>For work with five years Defect Liability Period:</p> <p>i) No security deposit shall be refunded to the contractor for 1<sup>st</sup> 3 years from the actual date of completion of the work;</p> <p>ii) 30% of the security deposit shall be refunded to the contractor on expiry of four years from the actual date of completion of the work;</p> <p>iii) The balance 70% of the security deposit shall be refunded to the contractor on expiry of five years from the actual date of completion of the work.</p>
41	<p>The successful bidder has to provide detailed estimate along with rate analysis (if any) for all civil and electro-mechanical works including planning, designing and drawings as per the clause 57 of Section C with all necessary break up elaborately for comparison of rate with departmental estimate if asked by the concerned authority before acceptance of bid which will be treated as part of the bid document.</p>
42.	<p>Clause 57 of Section C has been prepared on the basis of major items of the work so that contractor may get payment after completion of major items in a phase wise way . If any item the contractor feels as major item but not reflected in the clause will be pointed out during pre-bid meeting. All other items (if any) not shown in the payment schedule or in bid document but required for successful completion and commissioning of the project will be in the scope of Bidder.</p>
43.	<p>The bidder should take requisite reference from Report of Jadavpur University and CPHHEEO Manual.</p>

## INSTRUCTION TO BIDDERS/BIDDERS

### SECTION – A-I

#### **1. General guidance for e-Bidding**

Instructions/ Guidelines for bidders for electronic submission of the Bids have been annexed for assisting them to participate in e-Bidding.

#### **2. Registration of Bidder**

Any Bidder willing to take part in the process of e-Bidding will have to be enrolled and registered with the Government e-procurement system, through logging on to <https://wbtenders.gov.in> The Bidder is to click on the link for e-Bidding site as given on the web portal.

#### **3. Digital Signature certificate (DSC)**

Each Bidder is required to obtain a class-II or Class-III Digital Signature Certificate (DSC) for submission of Bids, from the service provider of the National Information's Centre (NIC) or any other bonafide service provider on payment of requisite amount. Details are available at the Web Site stated in Clause 2 of Guideline to Bidder. DSC is given as a USB e-Token.

#### **4. The contractor can search and download Nl&B and Bid Documents**

Electronically from computer once he logs on to the website mentioned in Clause 2 using the Digital Signature Certificate. This is the only mode of collection of Bid Documents.

#### **5. Submission of Bids.**

General process of submission, Bids are to be submitted through online to the website stated in Cl. 2 in two folders at a time for each work, one in Technical Proposal and the other is Financial Proposal before the prescribed date and time using the Digital Signature Certificate (DSC) the documents are to be uploaded virus scanned copy duly Digitally Signed. The documents will get encrypted (transformed into non-readable formats).

#### **A. Technical proposal**

The Technical proposal should contain scanned copies of the following further two covers (folders).

#### **A-1. Statutory Cover Containing**

##### **1. Prequalification Document**

- i. As per Sl. No. 4
- ii. Prequalification Application (Sec-B, Form – I)
- iii. Scanned Copy of online bank challan towards earnest money (EMD) as prescribed in the NleB against each of the serial of work.

**2. NleB**(download and upload the same Digitally Signed)

**3. Technical Document** (*To be filled, scanned & digitally signed*)

- i. Financial Statement (Section – B, Form – II).
- ii. Affidavits (Ref:-Declaration of theBidder)
- iii. Bank Solvency Certificate.
- iv. Form III & IV Of Section B.
- v. Declaration by the Bidder.

(The autocad drawing may be obtained from concerned divisional office after publishing of the bid document for showing locations of different items if required and sluice valve chambers and to be uploaded.)

**A-2. Non statutory Cover Containing/My Documents**

- i. Registration Certificate under Company Act. (if any).
- ii. Registered Deed of partnership Firm/ Article of Association and Memorandum
- iii. Power of Attorney (For Partnership Firm/ Private Limited Company, if any)
- iv. Tax Audit Report along with Balance Sheet and Profit and Loss A/c for the lastfiveyears(year just preceding the current Financial Year will be considered as year – I)
- v. Clearance Certificate for the Current Year issued by the Assistant Registrar ofCo-Op(S) (ARCS) bye laws are to be submitted by the Registered labour Co-Op(S) Engineers' Co.-Opt.(S)
- vi. List of machineries possessed by own/arranged through lease deed along with authenticated documents of lease / sub-lease / hire basis etc.
- vii. List of laboratory Instrument.
- viii. List of technical staff along with structure and organization (Section – B, Form – III).

Note: - Failure of submission of any of the above mentioned documents (as stated in A1 and A2) will render the Bid liable to be summarily rejected for both statutory and non-statutory cover.

**Intending Bidders should upload Non-Statutory documents as per following folders in My**

**Document:**

<b>E-Bidding system of Government of West Bengal</b>			
<b>Bidder Document Sub Category Master</b>			
<b>Sl. No.</b>	<b>Category Name</b>	<b>Sub Category Name</b>	<b>Sub Category Description</b>
A	CERTIFICATES		
		A1. CERTIFICATES	1. GST Registration / ST Registration/ P.F/PAN / P. Tax Clearance Certificate  2. Income Tax Acknowledgement Receipt (Latest)  3.E.S.I Registration Certificate.
B	COMPANY DETAILS		
		B1. COMPANY DETAILS 1	1. Proprietorship Firm (Trade License).  2. Registered Deed of partnership Firm  3. Registration Certificate under Company Act. (if any). Ltd.

			Company (Incorporation Certificate , Trade License)  4. Power of Attorney (For Partnership Firm/  Private Limited Company, if any)  5. Society (Society Registration copy, Trade License)
C	CREDENTIAL		
		C1. CREDENTIAL1	Similar nature Work & Completion Certificates along with work order and payment certificate issued by competent  authority (as per SI No. 4 of NleB)
D	EQUIPMENT		
		D1.LABOURTARY	1. List of Machineries and equipment
		D2. CIVIL MACHINERIES	necessary for field as well as laboratory test of
		D2. ELECTRICAL MACHINERIES	all materials as per NleB
		D2. MECHNANICAL MACHINERIES	
		D2. MISCELLENEOUS MACHINERIES	
E	FINANCIAL INFO		
		E1. P/L & BALANCE	P/L & BALANCE

		SHEET 2011-2012	SHEET (As per NleB)
		E2. PAYMENT CERTIFICATE 1	Payment Certificate in support of valid credential only to be submitted(as per NleB)
		E3 PAYMENT CERTIFICATE 2	
F	MANPOWER		
		F1. TECHNICAL PERSONNEL	1. List of sufficiently qualified technical person  (as per SI No 4 of NleB)
		F2. TECHNICAL PERSONNEL ON CONTRACT	1. List of technical personnel employed under the organization (or on contact basis ) in details  with name, qualification, experience and, address with contact number.
G	DECLARATION	DECLARATION 1	1. Bank Solvency Certificate (As per NleB)
		DECLARATION 2	2. Valid Document in support of annual  (As per NleB)
		DECLARATION 3	3. Corrigendum and additional document (if any).

**Note:- Failure of submission of any of the above mentioned documents (as stated in 5.A-1 & 5.A-2) will render the Bid liable to summarily rejected for both statutory & non statutory cover. All Corrigendum & Addendum Notices, if any, have to be digitally signed & uploaded by the contractor in the Declaration Folder of My Documents.**

### **B. Bid Evaluation**

- i. Opening and evaluation of Bid :- If any Bidder is exempted from payment of EMD, copy of relevant Government order needs to be furnished (applicable in case of Registered Labour Co-Operative Society).
- ii. Opening of Technical proposal: - Technical proposals will be opened by the Bid Inviting Authority electronically from the website using his/ her Digital Signature Certificate.
- iii. Cover (folder) of statutory documents (vide Cl. No. 5.A-1) should be opened first and if found in order, cover (Folder) for non-statutory documents (vide Cl. No. – 5.A-2) will be opened. If there is any deficiency in the statutory documents the Bid will summarily be rejected.
- iv. Decrypted (transformed in to readable formats) documents of the non-statutory cover will be downloaded and handed over to the Bid Evolution Committee. Scrutiny of technical proposal and recommendation thereafter and processing of comparative statement for acceptance etc. will be made by the Municipal Engineering Directorate, under the Deptt. of Municipal Affairs, Govt. of West Bengal. Comparative Statement may be forwarded to appropriate authority depending on the value of the work as applicable as per existing norms and guidelines under AMRUT programme.
- v. Uploading of summary list of technically qualified bidders.
- vi. Pursuant to scrutiny and decision of the screening committee the summary list of eligible Bidder and for which their proposal will be considered and uploaded in the web portals.
- vii. While evaluation, the committee may summon the bidders and seek clarification / information or additional documents or original hard copy of any of the documents already submitted and if these are not produced within the stipulated time frame, their proposals will be liable for rejection.

### **C. Financial proposal**

As per Sl. 11, Bid Price / Price Schedule to be uploaded Digitally signed by the Bidder.

**6.** Financial capacity of a Bidder will be judged on the basis of working capital and available bid capacity as mentioned in the NleB to be derived from the information furnished in **FORM-I and II** (Section-B) i.e., Application (for Pre-qualification) and Financial Statement. If an applicant feels that his/their Working Capital beyond own resource may be insufficient, he/they may include with the application a letter of guarantee issued by a first class Bank to supplement the applicant. This letter of guarantee should be addressed to the Bid Inviting/ Accepting Authority and should guarantee duly specifying the name of the project that in case of contract is awarded to the Bidder, the Bidder will be provided with a revolving line of credit Such revolving line of credit should be maintained until the works are taken over by the Authority.



The audited Balance sheet for the last five years, net worth bid capacity etc. are to be submitted which must demonstrate the soundness of Bidder financial position, showing long term profitability including an estimated financial projection of the next two years.

#### **7. Penalty for suppression / distortion of facts**

Submission of false document by Bidder is strictly prohibited and in case of such act by the Bidder the same may be referred to the appropriate authority for prosecution as per relevant IT Act with forfeiture of earnest money forthwith.

#### **8. REJECTION OF BID**

**The Employer (Bid accepting authority) reserves the right to accept or reject any Bid and to cancel the Bidding processes and reject all Bids at any time prior to the award of Contract without thereby incurring any liability to the affected Bidder or Bidders or any obligation to inform the affected Bidder or Bidders of the ground for Employer's (Bid accepting authority) action.**

The Bidder whose Bid has been accepted will be notified by the Bid Inviting and Accepting Authority through acceptance letter/ Letter of Acceptance. The Letter of Acceptance will constitute the formation of the Contract.

The Agreement in Printed Bid Form will incorporate all necessary documents e.g. NleB., all addenda-corrigendum, different filled-up forms (Section –B), Price Schedule and the same will be executed between the Bid Accepting Authority and the successful Bidder.

**The Chairman/ Administrator  
Burdwan Municipality**

SECTION – B

FORM –I

**PRE-QUALIFICATION APPLICATION**

**To**  
**The Chairman/ Administrator,**  
**Burdwan Municipality,**  
**Dist: -PurbaBurdwan,**  
**West Bengal,**

Ref: - Bid  
for \_\_\_\_\_

\_\_\_\_\_ (Name of work)

\_\_\_\_\_ **NleB No.:**

Dear Sir,

Having examined the Statutory, Non statutory and NleB documents, I /we hereby submit all the necessary information and relevant documents for evaluation. The application is made by me / us on behalf of \_\_\_\_\_ In the capacity \_\_\_\_\_ duly authorized to submit the order.

The necessary evidence admissible by law in respect of authority assigned to us on behalf of the group of firms for Application and for completion of the contract documents is attached herewith.

We are interested in bidding for the work(s) given in Enclosure to this letter.

We understand that:

- (a) Bid Inviting and Accepting Authority can amend the scope and value of the contract bid under this project.
- (b) Bid Inviting and Accepting Authority reserves the right to reject any application without assigning any reason.

**Enclo:- e-Filling:-**

- 1. Statutory Documents
- 2. Non Statutory Documents

Date: -

**Signature of applicant including title and capacity in which application is made.**

**SECTION – B**

**Form - II**

**FINANCIAL STATEMENT**

**B.1** Name of Applicant:

**B.2** Summary of assets and liabilities on the basis of the audited financial statement of the last five financial years. (Attach copies of the audited financial statement of the last five financial years)

	1st Year  (Rs. In lakh)	2nd Year  (Rs. In lakh)	3rd Year  (Rs. In lakh)	4th Year  (Rs. In lakh)	5th Year  (Rs. In lakh)
a) Current Assets : (It should not include investment in any other firm)					
b) Current liabilities : (It should include bank over draft)					
c) Working capital : (a) – (b)					
d) Net worth : (Proprietors Capital or Partners Capital or Paid up Capital + Reserve & surplus )					
e) Bank loan/ Guarantee : (As per clause G.2. with all sub clauses)					

**B.3** Annual value of construction works undertaken :

Work in hand i.e. Work order issued	As on 31.03.2020	As on 31.03.2019	As on 31.03.2018	As on 31.03.2017	As on 31.3.2016	As on 31.03.2015

Signed by an authorized officer of the firm

---

Title of the officer

\_\_\_\_\_

Name of the Firm with Seal

Date \_\_\_\_\_

**Declaration of the Bidder**

(Affidavit to be affirmed on a Non Judicial Stamp Paper of Rs. 10/- and enclosed with the Bid documents which is required to be submitted in time duly)

I, \_\_\_\_\_, son of \_\_\_\_\_

\_\_\_\_\_, aged about \_\_\_\_\_ ye \_\_\_\_\_ ars by occupation \_\_\_\_\_ do hereby solemnly aff irm and confirm as follow:

1. That, I am the \_\_\_\_\_ Of \_\_\_\_\_ have duly authorized by and compete nt to affirm this affidavit on behalf of the said Bidder.

2. That, I have inspected the site of work covered under NleB (NleB No \_\_\_\_\_ ) circulated through Office memo bearing No \_\_\_\_\_ dated \_\_\_\_\_ and have made myself fully acquainted with the site conditions existing level/proposed level and local conditions in and around the site of work. I have also carefully and meticulously gone through the Bid documents. Bid of the above named Bidder is offered and submitted upon due consideration of all factors and if the same is accepted, I on and for behalf of the aforesaid Bidder, being lawfully and duly authorized, promise to abide by all the covenants, conditions and stipulations of the Contractual documents and to carry out, complete the works to the satisfaction of the Bid accepting Authority of the Work and abide by all instructions as may given by the Engineer in Charge of the work time to time. I also hereby undertake to abide by the provisions of Law including the provisions of Contract Labour (Regulation & Abolition) Act, Apprentice Act 1961, West Bengal Sales Tax Act, VAT Act, Income Tax Act as would be applicable to the Contractor upon entering into formal Contract / agreement with the Bid Inviting/Accepting authority.

3. That I declare that, no relevant information as required to be furnished by the Bidder has been suppressed in the Bid documents.

4. That the statement above made by me is true to my knowledge.

Deponent

Solemnly affirmed by the said

.....  
Before me.....(1st clas s Judicial  
Magistrate / Notary Public)

**SECTION - B**

**FORM- III**

**STRUCTURE AND ORGANISATION**

**A.1** Name of applicant :

**A.2** Office Address :

Telephone No. and Cell Phone No. :

Fax No. :

E mail :

**A.3** Attach an organization chart showing the structure of the company with names of  
Key personnel and technical staff with Bio-data. :

**Note:** Application covers Proprietary Firm, Partnership, Limited Company or Corporation,

**Signature of applicant including title  
and capacity in which application is made**

**SECTION - B**

**FORM – IV**

**C. DEPLOYMENT OF MACHINERIES (in favour of owner / lessee): -**

(Original document of own possession arranged through lease deed to be annexed)

(If engaged before Certificate from E.I.C. to be annexed in respect of anticipated dated of release of Machineries.)

Name of Machine / Instrument	Make	Type	Capacity	Motor Engine No.	/ Machine No.	Possession Status		Date of release If Engaged
						Idle	Engaged	

For each item of equipment the application should attach copies of

- (i) Document showing proof of full payment, (ii) Receipt of Delivery,
- (iii) Road Challan from Factory to delivery spot, is to be furnished.

**Signature of applicant including title and capacity in which application is made.**

Copy Forwarded for information and for favour of wide circulation to:

1. The Director SUDA, SUDA BHAWAN, HC Block, Sector-III, Salt Lake, Kol-106.
2. The Mission Director, AMRUT, IlgusBhavan, Kol-700106, Sec-IV
3. The Secretary, M.E.Dte., BikashBhawan, Salt Lake, Kol-91
4. The Chief Engineer, M.E.Dte., BikashBhawan, Salt Lake, Kol-91.
5. The Chief Engineer KMDA (E/M), Salt Lake Kolkata,
6. The Additional Chief Engineer, M.E.Dte., BikashBhawan, Salt Lake, Kol-91.
7. The Superintendent Engineer, (Western Circle), M.E.Dte., PurbaBardhaman.
8. The Administrator & SDO SADAR(N)
9. The Superintendent Engineer KMDA (E/M), Salt lake Kolkata
10. The Executive Engineer, M.E.Dte. Burdwan Division.
11. The Executive Engineer, KMDA (E/M), Salt lake Kolkata
12. The Finance officer, Burdwan Municipality.
13. The O.S. for wide circulation in a day by National & local News Paper in Bengali, English and Hindi News Paper.
14. The Office Notice Board, Burdwan Municipality for wide circulation.
15. The Guard File.

**The Chairman/ Administrator  
Burdwan Municipality**

# INDEX

1	SECTION – A	BID NOTICE, CORRIGENDUM AND ADDENDUM (to be inserted)
2	SECTION – B	DECLARATION BY THE BIDDER
3	SECTION – C	PROJECT BACKGROUND WITH SALIENT INFORMATION
4	SECTION – D	SCOPE OF WORK
5	SECTION – E	SCHEDULE OF WORK
6	SECTION – F	PROCESS DESCRIPTION AND DESIGN PARAMETERS
7	SECTION – G	TECHNICAL INFORMATION
8	SECTION – H	SPECIFICATION OF WORK (CIVIL)
9	SECTION – I	GENERAL CONDITION OF CONTRACT
10	SECTION – J	ADDITIONAL CONDITION OF CONTRACT
11	SECTION – K	ADDITIONAL INFORMATION AND SPECIAL TERMS & CONDITIONS
12	SECTION – L	VENDOR LIST

**SECTION - A**  
**BID NOTICE, CORRIGENDUM AND**  
**ADDENDUM (To be inserted)**



**SECTION - B**  
**DECLARATION BY THE BIDDER**

**SECTION - C**  
**PROJECT BACKGROUND WITH SALIENT INFORMATION**

**5.2 Climatic Condition**

A dry tropical climate prevails in whole command area which is arid in nature with cold winter and very hot summer. The winter season prevails in 3 months from December to February followed by moderate temperature during March & middle of April, very hot summer between middle of April to Middle of June when monsoon starts and stay up-to middle of October. During the period between middle of October to end of November the climate remains soothing prior to commencement of cold winter. Approx. temperature of area is as follows:

	Winter	Summer	Rest of other season
<b>Maximum</b>	25o to 30o C	33o to 45o C	28o to 35o C
<b>Minimum</b>	5o to 10o C	25o to 30o C	20o to 28o C

**5.3 Annual Rain Fall**

The average annual rainfall for last 5 years in the project area is approx. 1100mm

**5.4 Geology and the Soil Condition**

Geological condition is mostly residual soil formed by weathering of Bed Rock. The area falls under the lateritic area of the state. The contractor shall obtain all soil characteristics through soil test to find out the exact nature of the soil. However, for Tendering purpose, the **Soil Bearing Capacity (SBC)** may be adopted as **7.5MT / Sqm.** and Subsoil water level shall be taken at the existing Ground Level. After award of contract if contractor's soil test results show SBC value less than **7.5 MT / Sqm**, the design is to be carried out with that soil test report, for which no extra cost shall be paid by MEDDte. to the contractor. However, if the soil tests results show SBC value greater than **7.5 MT / Sqm**, the design may be based on same.

**Note:-The information / data regarding the SBC shown above are indicative only. The Successful Tendered shall confirm the sizes of each component by their own design and shall submit the same to EIC for approval before construction. No extra claim shall be entertained by the M.E.Dte. for increase in size of units by the Successful Tendered.**

**6.0 CHARACTERISTICS OF WATER**

**6.1 Quality of Raw Water of Subsurface Water of River Damodar**

The Raw Water characteristics are varying from season to season and are generally as follows:

- i) pH Value: 8.32& 6.69 (monsoon season)
- ii) Turbidity (NTU): 2.99 &13.00 (monsoon season)
- iii) Total Dissolved Solids (mg/l) : 93.7, & 84 (monsoon season)
- iv) Chlorides (as Cl) (mg/l) : 34& 10.28 (monsoon season)
- v) Fluoride (as F)(mg/l) : 0 (monsoon season)
- vi) Iron (as Fe) (mg/l) : 0.5& 1.09 (monsoon season)
- vii) Manganese (as Mn) (mg/l) : Data not available
- viii)Alkanity (mg/l) : 16.92 (monsoon season)
- ix) Total Hardness (mg/l) : 148& 48 (monsoon season)
- x) Arsenic (mg/l): BDL(monsoon season)
- xi) TC: 1500 colonies& 136 CFU/100ML (monsoon season)
- xii) FC: nil& 84 CFU/100ML (monsoon season)

## 6.2 Treated Water Quality for Domestic Feed (Potable Water)

The quality of treated drinking water shall be as per IS 10500 -2012 /latest edition.

### 7.0 SALIENT INFORMATION

Survey, Planning, Design, Supply, Delivery, Erection, Construction, Commissioning and Completion in all respect all Civil and Electro- Mechanical Works including all others allied, related and enabling works for 2 nos. 22.73 MLD Capacity each Radial Collector Wells With Pump House, Access & Pipe carrying Bridge including 1 no HT Sub Station Building at Damodar River in between Belkash&Zuzuty village, protection work at river bank, Raw Water Rising Main from Radial Collector Wells to WTP as directed Hydro- geological investigation report of Jadavpur University along with all manifold line and necessary valves and accessories, and construction of boundary wall, approach road, drain with necessary civil, Electrical (according to Indian Electricity rules), Mechanical & all other allied works related for pump house with necessary approval from respective Competent Authority including lightening within yard, walkway and internal illumination complete in all respect on turnkey basis and after satisfactory completion and commissioning, 3 (three) months trial run, necessary training of maintenance staff & thereafter (subsequently) 5 (five) years operation and maintenance with security /guarding arrangement under AMRUT Project.

#### Project 7.1 Salient Features of the Project:

Sl. No.	Description	Details
1	Name of Scheme	: Burdwan water supply under AMRUT Project
2	Municipality	: Burdwan Municipality
3	District	: PurbaBurdwan
4	No. of ward	: 35 nos.
5	Population	
a	Population as per census 2011	: 314638
b	Designed population (2032)	: 376970
c	Designed population (2047)	: 426508
6a	Demand meet up through radial wells collector	: 45.47 MLD
6b	Demand meet up through Tube well	: 15.00 MLD
6c	Gross Demand	: 60.47 MLD
7	Source of water	: Sub surface water of river Damodar
8	Method of Extraction	: Through RadialCollector Wells
9	Treatment	: Source of Water is subsurface water ofriverDamodar and will be abstracted through Collector Wells. Hence, treatment is required tomake it potable as deem fit (not in scope of work).

10	Disinfection	:	Chlorination
11	Operational Hour of collector Wells	:	20 hrs.
12	Abridged schedule of works under scope of this Tender	:	Planning, survey, Soil Investigation work, Design & Construction of 2 nos 22.73 MLD capacity Radial Collector Wells, Access & Pipe carrying Bridges, Pump House over Radial Collector Wells, Sub-station Building, Office cum Go down, Guard Room, Bank protection, Paver Block topped Pathway, Internal surface Drain, Boundary Wall at Sub-Station area, Laying Raw Water Rising Main including hydro test & permanent road restoration work from Collector wells to WTP on construction of Bridge on Damodar River, DVC & Baka Khal, saddle support underground as required as per site condition including all civil & Electro-Mechanical Works and successful completion of 3 (three) months trial run, necessary training of maintenance staff & thereafter (subsequently) 5 (five) years operation.
<b>Brief Scope of works</b>			
13	Collector Wells		
a	Number of Collector Wells	:	2(two)
b	Inner Diameter of Collector Wells	:	6.0m minimum or as designed
c	Over all depth of Collector Well	:	Extend upto 2.00m above HFL and min. 18m below river bed and also as per design structural stability or as designed
d	Diameter of radial Stainless steel strainer	:	400 mm or as designed
e	Number and length of radial strainer	:	Total 24 Nos. of min 40.0m strainer length each in 2 layers and min. horizontal distance 3.0 m min. in between two strainer pipes and length of radial strainers required as per report of Jadavpur University depending upon hydraulic design based on hydro-geological study of subsurface water flow/storage characteristics of river Damodar

			to ensure withdrawal of required design water demand with adequate factor of safety whichever is more. The slot size of the strainer is kept at D10 of the gravel pack material to avoid segregation of the fine particles near the strainer opening ranging between 1.5 to 4 mm and the length 5 to 12 mm. Minimum of 12% opening or as designed to draw targeted quantity of water
14	M.S Access & Pipe carrying Bridge on Pile support on Damodar River		
a	Length of Bridge	:	Min. 534m. & 354m. & it should be at least 2.00m. above HFL
b	Width	:	3.00m minimum
15	Raw Water Rising Main		
a	Diameter & Length of Rising Main from Collector Wells to WTP	:	600 mm D.I (K9) of length 1550 m. on Collector wells Bridge and river bank and balance length approx. 9000m of 800mm DI (K/9).
b	Diameter & Length of Rising Main from common manifold to WTP	:	Suitable length & design dia. of DI/MS pipe.
16	Pump House over Collector Well	:	2 Nos. of 90.0m <sup>2</sup> Size each as required and it should be 2.00 m. above HFL.
17	Sub – Station Building	:	1 No. of 20.0mx11.0 m Size (min)
19	Guard Room	:	1 No. of 14.0m <sup>2</sup> Size (min)
20	Boundary Wall	:	175.0 m or as required as per site.
21	Bank protection	:	200.0 m or as required
22	Land Development	:	100 Cum or as required
23	Paver topped road		
a	4.0 m wide road	:	50.0m or as required
b	1.5 m wide road	:	50.0m or as required
24	Internal surface drain	:	50.0m or as required
25	Arboriculture and beautification	:	1 item
26	Soil testing	:	1 item
27	Hydrological study of Subsurface water flow/storage characteristics of river Damodar	:	1 item
28	Trial run	:	3 months
29	Operation and maintenance	:	5 years

## **SECTION - D**

### **SCOPE OF WORK**

#### **1.0 GENERAL**

The main scope of work envisages Survey, Planning, Design, Supply, Delivery, Erection, Construction, Commissioning and Completion in all respect of Civil and Electro- Mechanical Works including all others allied, related and enabling works for 2 nos. 22.73 MLD Capacity each Radial Collector Wells with laying of stainless steel strainer pipes by jackpushing method & desanding operation along with Pump House, Access & Pipe carrying Bridge at Damodar including HT Sub Station Building at Damodar River in between Belkash & Zuzuty village, protection work at river bank, Raw Water Rising Main including construction of Pipe carrying Bridge on Damodar (from Bank to Collector well) Banka & DVC Canal & Permanent Road restoration works from Radial Collector Wells to WTP as recommended Hydro- geological investigation report of Jadavpur University along with all manifold line and necessary valves and accessories, and construction of boundary wall, approach road, drain at Sub-station area with necessary Civil, Electrical (according to Indian Electricity rules), Mechanical & all other allied works related for pump house with necessary approval from respective Competent Authority including lightening within yard, pump house, walkway, Tubeline on Walkway for transporting pumps and accessories from bank to pump house and internal illumination complete in all respect on turnkey basis as per satisfaction of the department. After satisfactory completion and commissioning, 3 (three) months trial run, necessary training of maintenance staff & thereafter (subsequently) 5 (five) years operation and maintenance with security /guarding arrangement under AMRUT Project.

The Scheme shall be provided with Collector Wells with Pump House, Access Bridge, Raw Water Rising Main from wells to WTP, Clear Water Reservoir, High Lift Pump House, Sub-Station Buildings, Office cum godowns, Raw water and Clear Water Pumping Machineries and other allied Civil and Mechanical/Electrical Works. and related allied works are included in this Tender. The works under this Tender shall be based on hydrogeological study of subsurface flow/ storage characteristics for creation of sustainable source on rainfed of Damodar river as recommended by Jadavpur University, level survey, soil testing and planning thereafter, design and construction of various units, erection of supplied equipments, appurtenances, commissioning and O&M work.

Tender Inviting Authority however, reserves the right to accept or delete any item of Scope of works in full or part thereof.

#### **2.0 MAJOR ITEMS OF THE SCOPE OF WORK**

##### **1) Survey and Investigation:**

a) Level, Hydraulic, hydro-geological investigation at Damodar river in between Zuzuty & Belkash and Contour Survey for Collector Well Site, Sub-Station Building Site and Raw Water Rising Main from Collector Well to WTP Lakuty Jalkal building should be done by agency separately.

b) Soil exploration and soil investigation at Collector Well, Sub-Station Building site, at the Pier & abutment location for M.S Access Bridge on Damodar, Bakakhal & DVC channel should be done by agency separately.

Department may conduct a soil test and Hydro- geological investigation separately in that conservative criteria of soil test & Hydro- geological investigation shall be considered all the design parameter among these two shall be considered.

c) All the Components (Electromechanical and Civil) which are essential as per design for proper completion of work to achieve the desired target, are within the scope of work.

## **2) Planning & Design:**

a) Planning & Hydraulic design of Radial Collector Wells for withdrawal of design daily water demand of 45.47 MLD.

b) Planning, Architectural and Structural design of Collector Well, Pump House over Collector Well, SubStation Building, Office Cum godown, Guard Room, Boundary Wall, M.S Access Bridges min. 3.00 m wide with necessary abutments, piers, columns supported on RCC/Pile foundation, walkway and railing etc. for carrying raw water rising main from Collector Wells to WTP and submission of 6 (three) copies of design report and drawings both hard and editable soft copies.

### **NOTE:**

a) Vetting of design, drawing and relevant documents of all civil & Electro-Mechanical structures including hydraulic design for Collector Well should be done by any Govt. recognized Engineering Institute. However, M. E. Dte may also get such design/ drawing checked departmentally or through any other agency/organization/personnel decided by the Directorate, the cost of which is to be borne by the contractor.

b) Design of all civil & Electro-Mechanical structures in all parts shall be based on surveys, soil test report and hydro geological study etc. conducted separately by the successful bidder.

## **3) Execution and Construction:**

### **At Radial collector wells**

The following major works are required to be executed / constructed within the scope of the Tender.

a) Radial Collector Wells with Pump house having 1.5m wide walk way at periphery and inner diameter of 6.0 m. min. at wells and extend up to 2.00m. above HFL & 14m is below river bed level including 2 working 1 standby vertical turbine Pump in each well with all ancillary, allied and related all civil, Electro-Mechanical works: **2 Nos.**

b) M.S Access & Pipe carrying Bridge with necessary abutments, piers, columns supported on RCC/pile foundation, walkway and railing etc. for carrying raw water rising main from Collector Wells to WTP with all ancillary allied and related works: 3.00m wide approx. 534m. & 354m. **Length at Damodar and others area for laying of Rising main at Banka Khal & DVC canal approx. 100m each length.**

c) RCC framed single Stored Pump House over Collector Wells including all ancillary, allied and related works: **90.0m<sup>2</sup> Size-2 Nos.**

d) RCC framed Single Stored Sub Station Building including all ancillary, allied and related works: **220.0 m<sup>2</sup> size – 1No. (Capacity of Sub-station to be calculated to feed the 2 nos. 22.73 MLD capacity Radial collector wells and illumination.)**

e) RCC framed Single Stored Guard Room without water supply and sanitation arrangement including all ancillary, allied and related works: **14.0m<sup>2</sup> sizes – 1No.**

RCC framed Boundary Wall with Gate, with all ancillary, allied and related works at Sub-Station Building Site: **175.0m or as designed.**

f) supplying, laying, horizontal jack pushing, fixing of Stainless steel strainer pipe of required diameter & length designed by bidder, with desanding operation as per recommendation of Jadavpur University including surveying, Planning, design, drawing and construction of Civil, Electrical and Mechanical works including supply, carriage of all materials with necessary arrangement of Collector well and provision of following accessories. The slot size of the strainer is kept at D10 of the gravel pack material to avoid segregation of the fine particles near the strainer opening ranging between 1.5 to 4 mm and the length 5 to 12 mm. Minimum of 12% opening is recommended. The Stainless steel strainer pipes of 400 mm. dia.

of 12 mm thick. On every meter length of pipes with ribbed case holes of required nos. slotted holes of size as per code provision and approved Drawing in required nos. and Rows.

g) L.T. PDB panel at Collector wells end with 2 Nos. Air Circuit Breaker of required rating for receiving the power from L.T. PDB panel at high lift pump house including 4 Nos. star delta starters having all the safety of pump-motor for manual operating and remote operating Digital flow and discharge meter for calculate the discharge in sec, minute, hour, day, month and total discharge of water of Siemens L.& T and other approved make as per direction of E.I.C and necessary Collector wells internal illumination, yard lighting including necessary conceal wiring.

h) Vertical Turbine pump – motor discharge 600.00 cum per hour at the head of approx. 48.00 meter (actual discharge & head will be calculate by the bidder) 2 Nos. working and 1 No. Stand by for each well.

i) Planning, Design, Construction of Sub-Station building on ground floor 7 nos. room of Total area 220.0 Sqm 1) 1 No. for WBSEDCL room, 2) 1 No. for H.T. VCB Panel room, 3) 1 nos. for Transformer room, 4) 1 Nos. for LT Panel room, 5) 1 No. operator room cum store with toilet facility 6) 1 No. Auxilliary Transformer Room 7) 1 No. decorative type office room with vitrified tiles flooring, wall putty finishing wall and toilet facility by porcelain tiles on wall and also with 2.0 m High (From FGL) boundary wall with RCC Column, tie beam and lintels frame structure and fencing with barbed wire 600 mm height over boundary wall, one no. big gate (6000 mm width) and one no. small gate of 1200 mm width, approach road by RCC pavement, drain, Filling & Land development, beautification of Whole Premises up to HFL with ramming, compacting, leveling, and finishing complete in all respect as per approved drawing and direction of E.I.C at the entry point of the walkway.

j) Supply and installation of substation, required Amp HT VCB panel, 2 nos. 800 KVA transformer ( 1 Operating + 1 Standby), LT PDB panel, and H.T. Cable, L.T. cable all complete. k) Operation & maintenance: Operation and maintenance including supply of all accessories of the same for a period of 60 (Sixty) months after the completion of specified period of Successful Trial Run 3 moths. Source of Power for E/M works of 2 nos. Radial Collector Wells and other area to be taken from 800 kvasubstation. It should be connected through cable laying on cable tray at pipe carrying bridge as per IS Code provision and approved drawing by the EIC.

l) Laying of raw water rising main with specials & valve from collector well to WTP with all ancillary, allied and related works: 600 mm dia. DI (K9) 1550m. **length** at M.S Access Bridge & Laying of Underground Rising main approx. balance length of approx. 9000m of 800mm dia. with when and as required saddle support, Carrier Bridge.

m) Bank Protection by Boulder Sausage Work on Both Upstream and Downstream of Abutment of the Access Bridge for the Collector Well including All Ancillary, Allied and Related Works: **200.0 m min**

n) Land Development with all ancillary, allied and related works with carried earth arranged by the contractor at the Sub-Station Building Site: **100.0 cum min**

o) Construction of Paver Block Topped Internal road/ Path way at the Sub-Station Building Site:

a) 4.0m width Path way over 150mm thick PCC: **50.0 m min**

b) 1.5m width Path way over 100mm thick PCC: **50.0 m min**

p) Construction of masonry internal Surface drain having inside width 500mm and average depth 450mm having both side wall thickness 250mm at the Sub-Station Building Site: **50.0m min**

q) Arboriculture and Beautification with all ancillary, allied and related works at Sub-Station Building Site: **1 Item**

r) Soil Investigation including all allied works at the Collector Well, Sub-Station Building site, at the Pier & abutment location for M.S Access Bridge: **1 Item**

**4) Commissioning, Trial Run and Operation & Maintenance:** Commissioning, Trial run and O&M for the period as mention below are included in the scope of work.

a) Trial run of entire the entire system under this Tender for a period of 3 (three) months after successful commissioning.

b) Operation & Maintenance of entire the entire system under this Tender for a period of 5 (five)



Years after successful completion of three months trial run.

**NOTE: All data given above the scope of works as tentatively, bidder is responsible to take necessary survey, test and all consideration before submission of tender. The scope of Work, supply and service of plants and equipments may not be limited to the aforesaid items. The items though not specifically mentioned but needed to make the system complete in all respect and reliable for safe and smooth operation and guaranteed performance shall be included with related items in the price schedule.**

## **2.5 BROAD SCOPE OF WORK:**

Broad Scope of Works under this Tender is as under and also as detailed under various Sections of the Tender Document.

### **A) SURVEY & INVESTIGATION**

- (i) Level Survey for Collector Wells, Sub Station Building site and raw water rising main route from collector well to river bank shall be conducted by the successful bidder. Hindrance, if any, which are absolutely unavoidable, shall be shifted with proper permission of respective authorities. The design of various units is to be taken up on the basis of this survey work.
- (ii) Contour Survey at Collector Well & Sub Station Building site is to be done as per requirement and specifications.
- (iii) Soil exploration and soil investigation work for Collector Well, Substation Building and at the Pier & abutment location for M.S Access Bridge shall be carried out by the Successful Bidder, in order to determine the soil Properties, Soil Bearing Capacity (SBC) etc. The required depth of soil exploration & no. of bores for utility sites for construction of major structures shall be decided & carried out by the Contractor and shall be approved by EIC before starting the work. The sub-soil water level shall be taken at finished Ground Level for the purpose of evaluating the uplift pressure..
- (iv) Any other test/investigation required for design purpose.

### **B) PLANNING & DESIGN**

Planning and design of different components are to be done by the successful bidder based on the basic information obtained from survey, soil test, and other investigations conducted by the successful bidder. In doing such planning and design work the latest IS codes and design practices by using approved and accepted design software are to be used by the successful bidders.

Vetting of design, drawing and relevant documents of all civil structures should be done by any Govt. recognized Engineering Institute. However MED Dte. may also get such design/ drawing checked departmentally or through any other agency/organization/personnel decided by the Directorate, the cost of which is to be borne by the contractor.

### **C) EXECUTION & CONSTRUCTION**

Execution /construction of different item of works as described above are to be done following the procedure and specifications indicated elsewhere in this Tender document and following the best –Any other allied and related works to complete .

**2) Construction of Collector Wells having inner diameter of 6.0m min. and well extend upto 2.00m above HFL and also min. 18m below bed level and also structural stability as per IS code /relevant code provision. Provide with minimum 24 nos. of 40m long and 400mm diameter of radial strainers in each of the 2 layers as per drawing with all ancillary, allied and related works. Boulder sausage work of 1.0 m thickness by providing, placing, and setting in position laterite/ stone boulders of size 150 mm to 300 mm and above and of approved quality including emmeshed in 10 gauge G.I wire netting around the collector well 50.0 m from the outer wall of the well for preventing scouring in the immediate vicinity of the well during flood: 1No.**

1(One) no. Collector Well having inner diameter min. 6.0m.

2 layers 3m apart(min) with all ancillary, allied and related works will be constructed for withdrawal of subsurface water of river Damodar as source of water for the Piped Water Supply Scheme for Burdwan Municipality under AMRUT Scheme. This work should be executed in all respect with supply of all labors, materials, hire charges of machineries, equipments, tools & plants as per design, drawing, specification, scope of works, and different sections of Tender Document and direction of EIC. Major items

of works involved are given below:

→Cleaning site including cutting and removing jungles, bushes and shrubs with any kind of uprooting and layout of the work as per approved drawing in relation to the other works or structures as per direction of the EIC.

→Construction of Temporary Island and or temporary diversion of river course by construction of outerannular layer with two rows of bullahs, suitable spaced, of dia. not less than 150 mm, driven at least half of the total length, properly tied, braced and supported and filling the annular space with sand / soilfilled bags, protected by drum sheet walling on both side and filling the core portion with locallyavailable materials including the dismantling, removing and cleaning the site. Temporary Island should be maintained up to the completion of work for construction and sinking of collector well.

→Providing and constructing Temporary Service Road of width not less than 3.75 m over river for movement of men, equipment and construction machineries from river bank to collector well location considering necessary stability and safety aspects by providing and driving suitable piles, providing fitting, fixing suitable R.S. Joist, Channels, angles and wooden sleeper as per design requirement including dismantling and taking out the entire service road after construction.

→Supplying, fabricating and setting out steel cutting edge of collector well as per design, drawing and direction of the EIC.

→Providing and laying M30 grade Controlled Cement concrete or as designed in all parts of the Collector Well including base slab over the bottom plugged concrete except bottom plug concrete with well Graded stone chips (20mm size) excluding shuttering and reinforcement, with complete design of concrete as per IS:456 & relevant special publications submission of job mix formula after preliminary mix design after testing of concrete cubes including necessary vibrating, curing and cost for quality control, sampling, testing etc. as per direction of EIC. Consumption of cement will not be less than 500 Kg of cement with superplasticizer per cubic meter of controlled concrete but actual consumption will be determined on the basis of preliminary test and job mix formula [using concrete mixture]

→Providing and laying M25 Grade Controlled Cement concrete or as designed in bottom plug concrete with well graded stone chips (20mm nominal size) excluding shuttering and reinforcement with complete design of concrete as per IS: 456 and relevant special publications, submission of job mix formula after preliminary mix design after testing of concrete cubes including necessary vibrating, curing and cost for quality control, sampling, testing etc. as per direction of Engineer-in charge. Consumption of cement will not be less than 500 Kg of cement with Super plasticizer per cubic meter of controlled concrete but actual consumption will be determined on the basis of preliminary test and job mix formula. [using concrete mixture]

→Reinforcement for reinforced concrete work in all sorts of structure including distribution bar, stirrups binders etc. including supply of rod, initial straightening and removal of loose rust (if necessary) cutting to requisite length hooking and bending to correct shape placing in proper position and binding with 16mm. gauge black annealed wire at every inter section complete as per drawing & direction of the EIC. (i) HYSD Tor Steel/T.M.T bars Fe-500 grade (SAIL/ TATA/RINL).

→Hire and labour charges for shuttering with centering and necessary staging up-to 4 m using approved stout props and thick hard wood planks of approved thickness with required bracing for concrete slabs, beams and columns, lintels curved or straight including fitting, fixing and striking out after completion of works.

i) Steel shuttering or 9 to 12 mm thick approved quality ply board shuttering in any concrete work.

→Staging beyond 4M with stout bamboo / M.S or G.I tubular staging with necessary support and braces with necessary coir rope, nail, nut & bolts etc.

→Sinking of Well having 6.0m internal dia. as per IRC specification through all types of strata namely sandy soil, clayey soil and rock as shown against each case, including drawing Foundation Wells true to position and plumb including hire charges of all tools and plants etc. and supplying power, dewatering etc. initial excavation of earth complete as per drawing and technical specifications and direction of the Engineer-in-charge including throwing the spoils clear off the well up to 150m. radius through any kind of soil including rocky soil and rock till 25% of cutting edge (linear) comes in contact with rock including testing of bottom plug by dewatering the well up-to 5 meters and checking the rise in water level as per clause 1208 of IRC Specification.

→ Providing minimum 32 Nos. openings for potholes of 515 mm dia. in steining before concreting as per design and drawing.
→ Providing, fitting and fixing minimum 32 Nos. circular timber plate 615 mm X 75 mm thick

at the end of the Port holes before concreting.

- Fabricating supplying cast steel minimum 35 Nos. bullet heads and welding to slotted pipes.
- Supplying, fabricating minimum 35 nos. of 40m long each, 400mm diameter and 12mm thickness of stainless steel ribbed case type slotted pipe strainers and driving them horizontally at required depth and length; 24 Nos. in each of the 2 layers 3m apart.
- Fabricating supplying and welding minimum 35 Nos. or as required 400 mm dia. non-return sand valves in the first slotted pipes.
- Supplying fitting fixing minimum 35 Nos. or as required 400 mm dia. sluice valves as per I.S 14846 :2000 of approved make as per vendors' list to the well end of port holes including hand wheel connecting rods from sluice valves to valve operating gallery including guides, supporting clamps bushes etc. complete as to enable the operation of the valves from the gallery (which may be 15.0 m above the top of the valve) smooth and reliable.
- Supplying, fabricating & erecting mild steel support in the collector well for the erection of the pumps and other equipment.
- Supplying, fabricating and erecting steel/Aluminum ladder in the collector well from the pump house floor to the operating platform and from the operating platform to the bottom of the well.
- Supplying, fabricating & erecting an intermediate platform with hand railing, in the collector well for opening and closing of sluice valves.
- Supplying, fabricating & erecting floor of pump house with M.S Joist, angles and plates etc.
- Providing 20 mm dia. M.S rungs @ 400 mm c/c on the staining wall of collector well.
- Priming one coat on steel or metal surface with synthetic oil bound primer of approved quality including smoothing surfaces by sand papering etc.
- Painting two coats with best quality synthetic enamel paint of approved make and brand, approved colour & shade including smoothing surface by sand papering etc. including using of approved putty etc. on the surface, if necessary on steel or other metal surface with super gloss (hi-gloss).
- Conducting yield test of Collector Well after completion of all works as per specification by providing necessary numbers of VT/BHT or submersible pump sets of capacity as specified along with all accessories, tools and plants, generators, electrical connections, safety or control devices, water level measuring facilities inside the collector well and in the observation tubes during and after pumping as per direction including providing men and materials and lighting arrangement for conducting the test complete.
- Bailing / pumping out of any type water from trenches and / or any other sources.
- Filling in foundation or plinth by silver sand in layers not exceeding 150 mm as directed and consolidating the same by thorough saturation with water, ramming complete including the cost of supply of sand.

→ **Boulder sausage work of 1.0 m thickness by providing, placing, and setting in position laterite/ stone boulders of size 150 mm to 300 mm and above and of approved quality including emmeshed in 10 gauge G.I wire netting around the collector well 50.0 m from the outer wall of the well for preventing scouring in the immediate vicinity of the well during flood.**

- Providing flood gauge marks 75 mm wide strip by painting using approved paint with number, showing depth of water of every 250 mm on collector well.
- Cleaning, washing and disinfection of the collector well and making the same ready for trial run and commissioning.
- Making necessary barricading, fixing of caution boards, flags, fluorescent strips, lighting arrangement for works in night, traffic diversion where necessary.
- Removal of surplus excavated earth/spoils and cleaning the site in all respect.
- Any other allied and related works to complete construction of Collector Well in all respect.

**3) Construction of M.S Access Bridge with necessary abutments, piers, columns supported on RCC/Pile foundation, walkway and railing etc.** for carrying raw water rising main from Collector Well to river bank, Bakakhal & DVC canal **with all ancillary, allied and related works: 3.00 m wide -1No.**

1(One) M.S Access of Bridge 3.00m.m wide with necessary abutments, piers, columns supported onRCC/Pile foundation, walkway and railing etc. will be constructed for access to the Collector Well as well as carrying raw water rising main from Collector Well to river bank with all ancillary, allied and related works.

This work should be executed in all respect with supply of all labors, materials, hire charges of machineries, equipments, tools & plants as per design, drawing, specification, scope of works, different sections of Tender Document and direction of EIC. Major items of works involved are given below:

–Cleaning site including cutting and removing jungles, bushes and shrubs with any kind of uprooting and layout of the work as per approved drawing in relation to the other works or structures as per direction of the EIC.

–Providing and constructing Temporary Service Road of width not less than 3.75 m over river for movement of men, equipment and construction machineries from river bank to collector well location considering necessary stability and safety aspects by providing and driving suitable piles, providing fitting, fixing suitable R.S. Joist, Channels, angles and wooden sleeper as per design requirement including dismantling and taking out the entire service road after construction.

–Construction of Temporary Island and or temporary diversion of river course by construction of outerannular layer with two rows of bullahs, suitable spaced, of dia. not less than 150 mm, driven at least half of the total length, properly tied, braced and supported and filling the annular space with sand / soilfilled bags, protected by drum sheet walling on both side and filling the core portion with locallyavailable materials including the dismantling, removing and cleaning the site. Temporary Island should be maintained up to the completion of works for piers and abutment.

–Earth work in excavation of foundation trenches or drains up-to design depth, in all sorts of soil including mixed soil, laterite or sandstone and hard rock including controlled blasting and / or pavement breakers or any other equipment as approved by the Engineer-in-charge including removing, spreading or stacking the spoils within a lead of 75m. as directed. The item includes necessary trimming the sides of trenches, levelling, dressing and ramming the bottom, bailing out water as required complete. –Bailing / pumping out of any type water from foundation trenches and / or any other sources.

–Hire and labor charges for shoring work including necessary close plank walling, framing, Eucalyptus/ Jhou bulla piling, strutting etc. or sheet piling with necessary support and bracing where necessary, all complete as per direction of the Engineer-in-charge for foundation excavation.

–Preparation of bed of foundation trenches by ramming etc. as per direction of EIC.

–Filling in foundation or plinth by silver sand in layers not exceeding 150 mm as directed and consolidating the same by thorough saturation with water, ramming complete including the cost of supply of sand.

–Single Brick Flat Soling of picked jhama bricks including ramming and dressing bed to proper level and filling joints with local sand.

–Ordinary Cement concrete (mix 1:2:4) with graded stone chips (20 mm nominal size) excluding shuttering and reinforcement, if any as per relevant IS codes including compacting and curing.

–Drilling holes up to 15 cm dia. and up to 1.50 m depth through rock including bailing out / pumping out water and fitting / fixing anchor bolts 20 mm to 40 mm dia. with necessary fittings with cement concrete 1:1.5:3 using anti shrinkage admixture.

–Providing RCC cast in situ bored piles of required dia. in position in all kinds of soil except rock of any hardness including cost of boring by any method but using drilling mud to stabilize the bore and flushing the bore of excess mud with freshly prepared drilling fluid by using pumps prior to placing concrete by tremie method in one continuous operation and including the cost of all materials and labor for placing of concrete and also including the cost of hire charges of all equipments i.e. pile rigs and concrete thereof, welding of reinforcement cage as necessary and lowering reinforcement cage complete but excluding the cost of reinforcement and labor for bending, binding etc. work to be executed as per IS: 2011 (Part I / Sec.2). using Pakur/Rampurhat/Panchal variety or its equivalent stone chips, ultimate crushing strength of cement concrete should not be less than 350 kg/cm<sup>2</sup> on 15 cm cubes at 28 days with water cement ratio of 0.4 and slump 150-200 mm with minimum cement content of 500kg/m<sup>3</sup> including 1.0 m minimum dummy length of pile concrete.

–Providing and laying M30 grade Controlled Cement concrete in all parts of the Access Bridge in pile cap, column, pier, abutment, wing wall etc. with well Graded stone chips (20mm size) excluding shuttering and reinforcement, with complete design of concrete as per IS:456 & relevant special publications submission of job mix formula after preliminary mix design after testing of concrete

cubes including necessary vibrating, curing and cost for quality control, sampling, testing etc. as per direction of EIC. Consumption of cement will not be less than 500 Kg of cement with super plasticizer per cubic meter of controlled concrete but actual consumption will be determined on the basis of preliminary test and job mix formula [using concrete mixture].

→ Hire and labor charges for shuttering with centering and necessary staging up to 4 m using approved stout props and thick hard wood planks of approved thickness with required bracing for concrete slabs, beams and columns, lintels curved or straight including fitting, fixing and striking out after completion of works.

ii) Steel shuttering or 9 to 12 mm thick approved quality ply board shuttering in any concrete work.

→ Staging beyond 4M with stout bamboo / M.S or G.I tubular staging with necessary support and braces with necessary coir rope, nail, nut & bolts etc.

→ Reinforcement for reinforced concrete work in all sorts of structure including distribution bar, stirrups binders etc. including supply of rod, initial straightening and removal of loose rust (if necessary) cutting to requisite length hooking and bending to correct shape placing in proper position and binding with 16mm. gauge black annealed wire at every inter section complete as per drawing & direction of the EIC.

(i) HYSD Tor Steel/T.M.T bars Fe-500 grade (SAIL/ TATA/RINL).

→ Supplying, fabricating at shop suitable M.S Truss segments, transporting form shop to site and hoisting in position after necessary splicing at site with bolts and nuts M.S. Latticed Girders made of R.S Joist, angles, Channels, flats etc. conforming to IS: 226, IS: 808 and SP – 6 including hire charges of all lifting tackles, provision for walk way and hand railing.

→ Supplying, fitting and fixing in position true to line and levels approved Electrometric (Neoprene) Bearing as per IRC Code 83-Part I, including making of mortar / epoxy bed over sub – structure including its installation and testing.

→ Providing and laying in position on bridge deck RCC precast slabs of M25 cement concrete of 100 mm thick including shuttering vibrating curing etc. complete (including reinforcement steel and bending etc.) and all other materials and as per drawing design & instruction of EIC.

→ Providing GI railing integrated with GI post placed @450mm C/C and stiffened top and centrally with GI pipe, all made of 32mm dia. GI pipe (Medium quality of TATA make) on both sides of walk way including cost of GI pipe, Tee and cross where necessary cutting pipes, welding at every junction and intersection of pipes, welding the post with the M.S girder, all complete as per drawing and finished with two coats of synthetic enamel painting to all exposed surface of GI pipes as per direction and satisfaction of EIC. → Priming one coat on steel or metal surface with synthetic oil bound primer of approved quality including smoothing surfaces by sand papering etc.

→ Painting two coats with best quality synthetic enamel paint of approved quality, make, brand, approved colour and shade including smoothing surface by sand papering etc. including using of approved putty etc. on the surface, if necessary on steel or other metal surface with super gloss (hi-gloss).

→ Back filling of foundation trenches or filling the plinth or filling behind abutment / wing wall with good earth obtained from excavation, carried earth and or silver sand in layers not exceeding 150 mm including watering and ramming etc. layer by layer all complete.

→ Boulder sausage work of 1.0 m thickness by providing, placing, and setting in position laterite/ stone boulders of size 400 mm and above and of approved quality including G.I wire netting around the Piers, abutments and wing walls with 5.0 m radius around the Piers, abutments and wing walls for preventing scouring in the immediate vicinity of these structures/ components during flood.

→ Making necessary barricading, fixing of caution boards, flags, fluorescent strips, lighting arrangement for works in night, traffic diversion where necessary.

→ Removal of surplus excavated earth/spoils and cleaning the site in all respect.

→ Any other allied and related works to complete construction of M.S Access Bridge in all respect.

#### **4) Construction of RCC Framed Single Stored Pump House Over Collector Well including all ancillary, allied and related works: 90.0m<sup>2</sup> Size- 2 Nos.**

1(One) RCC Framed Single Stored Pump House of 90.0m<sup>2</sup> Size Over Collector Well including all ancillary, allied and related works will be constructed for installation of pumping machineries for pumping water from the Collector Well to CWR at Head Work Site. The work should be executed with supply of all labours, materials, hire charges of machineries, equipments, tools & plants as per design, drawing,

specification and direction of EIC.

Major items of works involved are given below:

-	Providing and casting M25 grade cement concrete (Design Mix) at an approximate height of 20 m from river bed for the following items for pump house including, vibrating curing etc.
	<p>a. Wall, Columns</p> <p>b. Lintel &amp; Cantilever projection</p> <p>c. Pump house floor (as per design)</p> <p>d. Roof and roof ring beams</p> <p>e. Cranes gantries and floor supporting brace etc.</p> <p>f. Columns supporting brackets of crane.</p> <p>- Supplying, bending, binding and laying in position HYSD or Steel/T.M.T bars Fe-500 grade reinforcement of different dimensions in cement concrete works of different components in superstructure including initial straightening of coil bars, removal of loose rust ( if any ), cutting to requisite length, bending, binding with annealed wire not less than 1 mm in size conforming to IS 280 at every intersection, hooked and bent to correct shape and placed on forms etc. including cost of black annealed wire and cost of loading, unloading, carriage of all steel materials.</p> <p>- Providing steel or plywood form work, scaffolding and staging for different components in foundation, substructure and super structure.</p>
-	<p>Providing 250 mm thick 1st class brick work with cement sand mortar (1:5) &amp; 125 mm thick brick work with cement sand mortar (1:4).</p> <p>Providing opening for doors, windows and ventilators and exhaust fans etc.</p> <p>Providing plaster to wall, beam, column, floor, walking platform with cement sand mortar (1:5), Ceiling plaster with cement sand mortar (1:3) and neat cement punning for skirting at floor level of minimum 2.00mm thickness on both side up to 400 mm high.</p> <p>Providing supplying steel doors / windows with integrated grills conforming to IS 1038 - 1975 and manufactures from rolled steel section including hoisting in position fixing in cement concrete,</p> <p>brickworks, complete in all respect including glazing of 3 mm (mins) thickness. Supplying fitting fixing steel rolling shutter (gear operated) profile type with 18 BG of approved type steel latch section 75 mm wide fitted with coil wire spring to necessitate the fitting of required Number of C.I.</p> <p>Pulley on heavy type solid drawn seamless steel complete with locking arrangement both inside and outside, guide channels hood. Providing and laying Ironite floor with proper grade, slope laid in panels. Providing M.S/G.I. hand railing where necessary for safety.</p> <p>Applying plastic emulsion paint two coats over two coats of primer on the inside face and ceiling of the pump house.</p> <p>Applying two coats of weather coat painting over two coats of primer on the outside faces of the pump house and other structures etc</p>
-	Applying 2(two) coats of synthetic enamel paint of approved quality, approved colour & shade over
-	two coats of red oxide primer on metal surface
-	Providing roof treatment with screed concrete (1:2:4) of 50mm average thickness with water proofing compound laid in panels with proper slope
-	Making necessary barricading, fixing of caution boards, flags, fluorescent strips, lighting arrangement for works in night, traffic diversion where necessary.
-	Removal of spoils and cleaning the site in all respect.
-	- Any other allied and related works to complete construction of <b>Pump House</b> in all respect.
-	
-	

## 5) Construction of

**(a) RCC Framed Single Storeyed Sub Station Building including Plinth Protection and Surface Drain including all ancillary allied and related works: 220.0 m<sup>2</sup> Size-1 No. at Intake Site.**

**(b) RCC Framed Single Storeyed Guard Room including Plinth Protection and Surface Drain including all ancillary allied and related works: 14.0 m<sup>2</sup> Size-1 No.**

1(One) RCC Framed Single Storeyed Sub Station Building of 220.0 m<sup>2</sup> size including Plinth Protection and Surface Drain including all ancillary, allied and related works will be constructed at the Sub Station

Building Site to receive electric power and providing power supply to pumping machineries and other equipments. 1(One) RCC Framed Single Storeyed Office Cum Godown of 10.0m<sup>2</sup> size including Plinth Protection and Surface Drain with water supply and sanitation arrangement including all ancillary, allied and related works will be constructed at the Sub Station Building Site for its intended use as Office and Site Godown for storing of materials/spares during Operation and Maintenance Period.

1(One) RCC Framed Single Storeyed Guard Room of 14.0m<sup>2</sup> size including Plinth Protection and Surface Drain including all ancillary, allied and related works will be constructed at the entrance of the Sub Station Building Site for watching and guarding purpose.

These works should be executed in all respect with supply of all labors, materials and hire charges of machineries, equipments, tools & plants as per design, drawing, specification and direction of EIC. Major items of works involved are given below:

-	Cleaning site including cutting and removing jungles, bushes and shrubs with any kind of uprooting and layout of the work as per approved drawing in relation to the other works or structures as per direction of the EIC.
-	Dismantling brick masonry, plain cement concrete, reinforced cement concrete etc. and stacking serviceable materials at site and removing rubbish as directed within a lead of 75.0 m. Earth work in excavation of foundation trenches or drains, in all sorts of soil including mixed soil,
-	
-	

Laterite or sandstone and hard rock including removing, spreading or stacking the spoils within a lead of 75m. as directed. The item includes necessary trimming the sides of trenches, leveling, dressing and ramming the bottom, bailing out water as required complete.

-	Bailing / pumping out of any type water from foundation trenches and / or any other sources.
-	Hire and labor charges for shoring work including necessary close plank walling, framing,
-	Eucalyptus/Jhou bulla piling, strutting etc. or sheet piling with necessary support and bracing where necessary, all complete as per direction of the Engineer-in-charge for foundation excavation.
-	Preparation of bed of foundation trenches by ramming etc. as per direction of EIC.
-	

- Filling in foundation or plinth by silver sand in layers not exceeding 150 mm as directed and consolidating the same by thorough saturation with water, ramming complete including the cost of supply of sand.

- Single Brick Flat Soling of picked jhama bricks including ramming and dressing bed to proper level and filling joints with local sand. BFS should be provided below PCC in foundation / floor etc.

- Ordinary Cement concrete (mix 1:2:4) with graded stone chips (20 mm nominal size) excluding shuttering and reinforcement, if any as per relevant IS codes including compacting and curing with Pakur variety stone chips.

- Ordinary Cement concrete (mix 1:1.5:3) with graded stone chips (20 mm nominal size) excluding shuttering and reinforcement if any as per relevant IS codes including vibrating, curing and cost for quality control, sampling, testing etc. in RCC work for all components of the building. Pakur variety stone chips should be used.

- Reinforcement for reinforced concrete work in all sorts of structure including distribution bar, stirrups binders etc. including supply of rod, initial straightening, and removal of loose rust (if necessary) cutting to requisite length hooking and bending to correct shape placing in proper position and binding with 16mm. gauge black annealed wire at every inter section, complete as per drawing & direction of the EIC. (i) HYSD Tor Steel/T.M.T bars Fe-500 grade (SAIL/ TATA/RINL)

- Hire and labor charges for shuttering with centering and necessary staging up-to 4 m using approved stout props and thick hard wood planks of approved thickness with required bracing for concrete slabs, beams and columns, lintels curved or straight including fitting, fixing and striking out after completion of works.

i) Steel shuttering or 9 to 12 mm thick approved quality ply board shuttering in any concrete work.

- Staging beyond 4M with stout bamboo / M.S or G.I tubular staging with necessary support and

braces with necessary coir rope, nail, nut & bolts etc.

→ 250 mm thick brick work with 1st class bricks in cement mortar (1:6) & 125 mm thick brick work with 1st class bricks in cement mortar (1:4) in foundation, plinth and super structure etc.

→ Providing opening for doors, windows, ventilators and exhaust fans etc. as per approved drawing.

→ Plaster (to wall, floor, ceiling etc.) with sand and cement mortar including rounding off or chamfering corners as directed and raking out joints including throating, nosing and drip course, scaffolding/staging where necessary including chipping over concrete surface. i) With 1:6 cement mortar

a) 20 mm thick on rough surface of brick work

b) 15 mm thick on plumed surface of brick work

ii) With 1:4 cement mortar

a) 10 mm on vertical concrete surface, ceiling of roof and chajja.

→ Providing supplying steel doors, steel /aluminium windows with integrated grills conforming to IS 1038-1975 and manufactures from rolled steel section including hoisting in position fixing in cement concrete, brick works including supplying 1.5mm thick M.S. sheet fitted and fixed on one or both faces of M.S./W.I. gate /door etc. with point welding at not more than 150mm apart or glazing of 3 mm (min) thickness, complete in all respect as per design including cost of all labour and materials. → Supplying, fitting and fixing steel rolling shutter (gear operated) profile type with 18 B.G. of approved type steel latches section 75mm wide, fitted with coil wire spring to necessitate the fitting of required Nos. of C.I. Pulleys on heavy type solid drawn seamless steel tube complete with locking arrangements both inside and outside specially built up side guide channels including providing a hood for the steel rolling shutter in the room, painting two coats of approved aluminum paint over a coat of red lead primer complete.

→ Supplying, fitting fixing best quality PVC doors with all fixtures for bath rooms only as per standard specification and direction of the EIC.

→ 35 mm thick Artificial stone in floor, dado, staircase etc. with cement concrete (1:2:4) with stone chips, laid in panels as directed with topping made with ordinary or white cement (as necessary) and marbledust in proportion (1:2) including smooth finishing and rounding off corners including raking out joints or roughening of concrete surface and application of cement slurry before flooring works using cement @ 1.75 kg/sq.m all complete including all materials and labor with 3 mm thick topping.

i) Floor of the all building except Pump House, office room, toilet and bath room should be Artificial Stone Floor

ii) Floor of the Pump House should be Ironite Floor.

iii) Floor of toilet and bathroom should be made with vitrified tiles

→ Neat Cement punning about 3mm thick in wall dado window, sills, floor and drain etc.

→ Supplying and laying true to line and level vitrified tiles of approved brand (size not less than 600 mm X 600 mm X 10 mm thick) in floor, skirting etc. set in 20 mm sand cement mortar (1:4) and 2 mm thick cement slurry back side of tiles using cement @ 2.91 Kg./sqm or using polymerised adhesive (6 mm thick layer applied directly over finished artificial stone floor/Mosaic etc without any backing course) laid after application slurry using 1.75 Kg of cement per sqm below mortar only, joints grouted with admixture of white cement and colouring pigment to match with colour of tiles / epoxy grout materials of approved make as directed and removal of wax coating of top surface of tiles with warm water and polishing the tiles using soft and dry cloth up-to mirror finish complete including the cost of materials, labor and all other incidental charges complete true to the manufacturer's specification and direction of Engineer-in-Charge.

i) Deep Colour & White on the floor of office room.

ii) Anti-Skid, Full Body, Homogeneous & Granular finish Vitrified Tiles on the floor of Toilet and bath room etc.

→ Supplying, fitting & fixing best quality digital printed Ceramic tiles in coloured decorative on walls and floors to match with the existing work & 4 nos. key stones (10mm) fixed with adhesive 4.5 mm thick at the back of each tile & finishing the joints with white cement mixed with colouring oxide if required to match the colour of tiles including roughening of concrete surface, if necessary or by synthetic adhesive & grout materials etc. with polymerised adhesive and epoxy grout pointing including spacer- 2mm (When tiles are laid over existing hard ready surface) all complete as per direction of Engineer-in-charge.

→ On the wall of the toilet and bath room etc.

→ Supplying and laying 25 mm thick chequered tiles of any shade & of approved quality with (1:1½:3) cement concrete laid in panels or patterns as directed in pavement, footpath etc. including necessary underlay 25 mm thick [avg.] cement mortar (1:3) complete in all respect with all labor and materials



using cement slurry @ 4.4 kg/sqm at back side and @2.4 kg/sqm for joint filling (Red Variety).

→Supplying super plasticizer of sika/cico conforming to IS-2645-1975 & IS-9130-1979 to be needed in mortar admixture @ 0.20% by weight of cement (i.e. 100ml. Per 50KG of cement) for improving workability reducing shrinkage & improvement of water lightness of the concrete.

→M.S. or W.I. ornamental grill weighing above 16 Kg./sqm of approved design joint continuously welded with M.S., W.I. flats and bars for window, railing, verandah etc. fitted and fixed with necessary screw and lugs.

→Providing GI railing integrated with GI post placed @450mm C/C and stiffened top and centrally with GI pipe, all made of 32mm dia. GI pipe (Medium quality of TATA make) including cost of GI pipe, Tee and cross where necessary cutting pipes, welding at every junction and intersection of pipes, embedding the post in the concrete floor up to a minimum depth of 80mm all complete as per drawing and finished with two coats of synthetic enamel painting to all exposed surface of GI pipes as per direction and satisfaction of EIC.

→Construction of RCC cable trench of 1.0 m wide and 1.0 depth with curb angle for substation building including earth work in excavation in any kind of soil with necessary sand filling, BFS, P.C.C(1:2:4), R.C.C work in M-20 grade concrete and reinforcement with Fe-500/550 D grade steel, shuttering, backfilling of the foundation trench, all complete as per drawing and direction of the EIC.

→Construction of ramp having full width of the door or gate openings for Sub Station building and steps for other buildings including earth work in excavation in any kind of soil with necessary sand filling, BFS, P.C.C(1:2:4), R.C.C work in M-20 grade concrete and reinforcement with Fe-500/550 D grade steel, brick work, plastering and neat cement punning, shuttering, back filling of the foundation trench, all complete as per drawing and direction of the EIC.

i) Ramp should be finished with chequered tiles

ii) Steps should be finished with AFS and neat cement finish.

→Back filling of foundation trenches or filling the plinth with good earth obtained from excavation and or silver sand in layers not exceeding 150 mm including watering and ramming etc. layer by layer all complete.

→Making arrangement for water supply and sanitation with supplying and laying (underground/above ground/conceal) of UPVC /CPVC pipes, specials, fittings, valves and all accessories such as water closet, wash basin, C.P bib cock, pillar cocks, taps, shower, soap tray, mirror, towel rail and PVC storage tank etc. of approved quality and make including construction septic tank, soak well, inspection pit, complete in all respect with supply of all labors and materials as per drawing and direction of the EIC.

→Applying two coats of Acrylic Distemper to interior wall, ceiling with a coat of solvent based interior grade acrylic primer (as per manufacturer's specification) including cleaning and smoothening of surface.

→Applying Two Coats Exterior Grade Acrylic primer of approved quality and brand on plastered or concrete surface old or new surface to receive decorative textured (matt finish) or smooth finish acrylic exterior emulsion paint including scraping and preparing the surface thoroughly, complete as per specification manufacturer's and as per direction of the EIC.

→Applying Two Coats of super Protective and Decorative Acrylic exterior emulsion paint of approved quality, as per manufacturer's specification and as per direction of EIC to be applied over acrylic primer as required.

(a) (a) Super Protective 100% Acrylic Emulsion.

→Priming one coat on steel or metal surface with synthetic oil bound primer of approved quality including smoothening surfaces by sand papering etc.

→Painting two coats with best quality synthetic enamel paint of approved quality, make, brand, approved color and shade including smoothening surface by sand papering etc. including using of approved putty etc. on the surface, if necessary on steel or other metal surface with super gloss (hi-gloss).

→Providing roof treatment with screed concrete (1:2:4) of 50mm average thickness with water proofing compound laid in panels with proper slope including preparing the surface.

→Supplying, fitting & fixing rain water pipe of UPVC pipes A- Type and fittings conforming to IS:13592-1992 with all necessary clamps nails, including making holes in walls, floor etc. cutting trenches in any soil through masonry concrete structures etc. if necessary and mending good damages including joining with jointing materials.

i) 110 mm OD

→Construction of plinth protection with surface drain around the building including earth work in excavation in any kind of soil with necessary sand filling, BFS, P.C.C(1:2:4), brick work, plastering

AFS and neat cement punning, shuttering, back filling of the foundation trench, complete in all respects as per drawing and direction of the EIC.

-	Making necessary barricading, fixing of caution boards, flags, fluorescent strips, lighting arrangement for works in night, traffic diversion where necessary.
-	Removal of surplus earth or spoils and cleaning the site in all respect.
-	Any other allied and related works to complete construction of these Buildings in all respect.
-	
-	

**6) Construction of RCC Framed Boundary Wall with M.S Gate with all ancillary, allied and related works at the Sub Station Building Site: 175.0m**

RCC Framed Boundary wall of 2.0 m height above the finished G.L will be constructed at the Sub Station Building Site for a total length of 175.0 m. to prevent entry of trespassers and cattle for safety of the Sub Station Building Site. This work should be executed in all respect with supply of all labors, materials and hire charges of machineries, equipments, tools & plants as per design, drawing, specification and direction of EIC. Major items of works involved are given below:

-	Cleaning site including cutting and removing jungles, bushes and shrubs with any kind of uprooting and layout of the work as per approved drawing in relation to the other works or structures and demarcation of land as per direction of the EIC.
-	Dismantling brick masonry, plain cement concrete, reinforced cement concrete etc. and stacking serviceable materials at site and removing rubbish as directed within a lead of 75.0 m. Earth work in excavation of foundation trenches or drains, in all sorts of soil including mixed soil, laterite
-	
-	

or sandstone and hard rock including removing, spreading or stacking the spoils within a lead of 75m. as directed. The item includes necessary trimming the sides of trenches, leveling dressing and ramming the bottom, bailing out water as required complete.

-	Bailing / pumping out of any type water from foundation trenches and / or any other sources.
-	Hire and labor charges for shoring work including necessary close plank walling, framing, Eucalyptus/Jhou bulla piling, strutting etc. or sheet piling with necessary support and bracing where necessary, all complete as per direction of the Engineer-in-charge for foundation excavation. Preparation of bed of foundation trenches by ramming etc. as per direction of the EIC. Filling in foundation or plinth by silver sand in layers not exceeding 150 mm as directed and consolidating the same by thorough saturation with water, ramming
-	complete including the cost of supply of sand Single brick flat soling of picked jhama brick
-	including ramming and dressing bed to proper level & filling joints with powdered earth or local sand in foundation and plinth. BFS should be provided below PCC in foundation/floor etc.
-	Ordinary Cement concrete (mix 1:2:4) with graded stone chips (20 mm nominal size) excluding shuttering and reinforcement, if any as per relevant IS codes including compacting and curing with Pakur variety stone chips.
-	Ordinary Cement concrete (mix 1:1.5:3) with graded stone chips (20 mm nominal size) excluding
-	
-	

shuttering and reinforcement if any as per relevant IS codes including vibrating, curing and cost for quality control, sampling, testing etc. in RCC work for all components of the boundary wall. Pakur variety stone chips should be used.

→ Reinforcement for reinforced concrete work in all sorts of structure including distribution bar, stirrups binders etc. including supply of rod, initial straightening and removal of loose rust (if necessary) cutting to requisite length hooking and bending to correct shape placing in proper position and binding with 16mm. gauge black annealed wire at every inter section complete as per drawing & direction of the EIC. (i) HYSD Tor Steel/T.M.T bars Fe-500 grade (SAIL/ TATA/RINL).

→ Hire and labor charges for shuttering with centering and necessary staging up-to 4 m using approved stout props and thick hard wood planks of approved thickness with required bracing for concrete slabs, beams and columns, lintels curved or straight including fitting, fixing and striking out after completion of works. (i) Steel shuttering or 9 to 12 mm thick approved quality ply board shuttering in any concrete work

→	250 mm thick brick work with 1st class bricks in cement mortar (1:6) & 125 mm thick brick work with
→	1st class bricks in cement mortar (1:4) in foundation, plinth and super structure etc. Plaster (to wall, floor, ceiling etc.) with sand and cement mortar including rounding off or chamfering
→	

corners as directed and raking out joints including throating, nosing and drip course, scaffolding/staging where necessary including chipping over concrete surface. i) With 1:6 cement mortar

i) 20 mm thick on rough surface of brick work

ii) 15 mm thick on plumbed surface of brick work ii) With	1:4 cement mortar
a) 10 mm on vertical concrete surface Neat Cement punning about 3mm thick in wall dado, skirting, window sills, floor and drain etc. Backfilling of foundation trenches or filling the plinth with good earth obtained from excavation and or silver sand in layers not exceeding 150 mm. including watering and ramming etc. layer by layer complete. Supplying, fixing and fixing in position M.S/W.I Ornamental Grill joint continuously welded with M.S., W.I. flats and bars, M.S Gate of approved design made of M.S rolled Section and 1.5mm thick M.S. sheet fitted and fixed on one or both faces of M.S./ W.I. gate. Supply, fitting and fixing in position Cattle Catcher made of M.S/G.I Pipes, M.S angle, flat, bars etc. Applying Two Coats Exterior Grade Acrylic primer of approved quality and brand on plastered or concrete surface old or new surface to receive decorative textured (matt finish) or smooth finish acrylic	
→	
→	
→	
→	
→	

exterior emulsion paint including scraping and preparing the surface thoroughly, complete as per specification manufacturer's and as per direction of the EIC.

→	Applying Two Coats of super Protective and Decorative Acrylic exterior emulsion paint of approved quality, as per manufacturer's specification and as per direction of EIC to be applied over acrylic primer as required (a) Super Protective 100% Acrylic Emulsion. Priming one coat on steel or metal surface with synthetic oil bound primer of approved quality including smoothening surfaces by sand papering etc.
---	---

	Painting two coats with best quality synthetic enamel paint of approved make and brand including smoothing surface by sand papering etc. including using of approved putty etc. on the surface, if necessary on steel or other metal surface with super gloss (hi-gloss). Making necessary barricading, fixing of caution boards, flags, fluorescent strips, lighting arrangement for works in night, traffic diversion where necessary. Removal of surplus earth or spoils and cleaning the site in all respect. Any other allied and related works to complete construction of Boundary Wall in all respect.
—	
—	
—	
—	
—	

**7) Laying Raw Water Rising Main from Collector Well to river bank on the Access Bridge with all ancillary, allied and related works per Departmental design and drawing: 600 mm dia. DI (K9) & 800mm dia. DI (K9) – 1 items .**

Raw Water Rising Main will be laid from the Collector Wells to the CWR at Head Work WTP Site for pumping subsurface water of river Damodar abstracted through Collector Well. Only the portion of Raw Water rising main from the Collector Well to WTP of required length will be laid under this Tender. The work should be executed with supply of all labors, materials except DI(K9) pipes which will be supplied departmentally free of cost, hire charges of machineries, equipments, tools & plants as per departmental design, drawing, specification and direction of EIC. Major items of works involved are given below:

—	Carriage of departmental materials i.e. DI (K9) pipes from the Municipal Store at Burdwan to Work Site including loading, unloading and stacking properly as per direction of the E.I.C. Providing in Alignment, laying and jointing of D.I.(K-9)/C.I./M.S/C.I.D.F/D.I.D.F pipes with Tyton joints/Flanged joints /Mechanical joints etc. on the Access Bridge including cutting and chamfering pipes
—	

with supply of lubricant of approved quality, all jointing materials, hiring of tools and tackles etc. (D.I./C.I./D.F/D.I.D.F pipes and rubber gaskets will be supplied departmentally free of cost.)

—	Supply and delivery at site any kind of Ductile Iron specials and fittings such as Bends, Tees, Hydrant Tees, Tapers, Flanged Spigot Tail Pieces, Flanged Sockets Tail Pieces, M.J Collars etc. as per IS 9523: 2000 (Push on joints, Mechanical joints or Flange joints) of approved make and quality including loading, carriage, unloading and stacking and aligning, laying and jointing of the same with supply of all jointing materials.
---	---

— Supply and delivery at site any kind of C.I.D.F valves such as sluice valves (IS:14846-2000), non-return valves (IS 5312: 2004), air valves (IS 14845: 2000) etc. of approved make and quality, including loading, carriage, unloading and stacking and aligning, laying and jointing of the same with supply of all jointing materials.

—	Supplying, fitting and fixing of M.S supports/benching arrangement for laying of DI (K9) pipe line on the Access Bridge. Supply and delivery of M.S.E.R pipes of different dia. of 10 mm thick of Fe 410 grade as per I.S 3589 –
—	

2001 including loading, carriage, unloading and stacking for interconnection of the Raw Water Rising Main with the common header of the raw water pumps.

—	Supply, fabrication and jointing any type M.S specials of different dia. made of M.S.E.R pipes of 10mm thick of Fe 410 grade conforming to I.S 3589 – 2001 for interconnection of the Raw Water Rising Main with the common header of the raw water pumps. Construction of masonry sluice/ washout/ reflux/ non-return/ air valve chamber with supply of approved type of RCC cover including earth work in excavation, bailing out water, single layer B.F.S and cement concrete (1:2:4) with stone chips in foundation, brick work in
---	---

	cement mortar (1:6) with 1st class brick with provision of weep holes at bottom, 100mm thick precast RCC slab (1:1.5:3) with necessary shuttering & reinforcement work (Fe-500 grade steel) and other materials, fitting, fixing, overhauling the valves if necessary to work in proper order, all complete including cost of all labours, materials, carriage etc. (valves & tail pieces only will be supplied departmentally free of cost). The work should be done as per Department Drawing no CC/49/91-RIV.
→	
→	Design and Construction of R.C.C thrust blocks and anchor blocks including earth work in excavation in any kind of soil, sand filling, single layer B.F.S, 100 mm thick P.C.C. (1:2:4), ordinary cement concrete (1:1.5:3), necessary reinforcement (Fe-500 grade steel), shuttering including vibrating, curing and back filling of the trench all complete.
→	Providing steel/ply board shuttering, scaffolding, staging etc. with necessary support and bracings. Making necessary barricading, fixing of caution boards, flags, fluorescent strips, lighting arrangement for works in night, traffic diversion where necessary. Testing hydraulically, all classes, all types of completed pipelines for a specified head of water in sections including supply of necessary equipments, gauge and other testing tools, required water and labors etc. all complete as per specification and direction of the EIC. Washing cleaning & disinfecting of all completed pipe lines with chlorinated water with at least chlorinated doses of 5mg/litre of water as per specification & direction of the EIC
→	Priming one coat on steel or metal surface with synthetic oil bound primer of approved quality including smoothing surfaces by sand papering etc. Painting two coats with best quality synthetic enamel paint of approved make and brand, color and shade including smoothing surface by sand papering etc. including using of approved putty etc. on the surface, if necessary on steel or other metal surface with super gloss (hi-gloss). Removal of surplus excavated earth/spoils and cleaning the site in all respect. Any other allied and related works to complete laying of Raw Water Rising Main on Access Bridge in all respect.
→	

**8) Design, Supply and Providing Bank Protection by Boulder Sausage Work on Both Upstream and Downstream of Abutment of the Access Bridge for the Collector Well Including All Ancillary, Allied and Related Works: 200.0 M**

**Length: 200.0m, Width (Min): Length in slope of embankment + 2.5 min for apron**

**Thickness of boulder sausage: (i) in slope of embankment :0.45 m (min) and (ii) in apron: 0.75m (min)**

This work should be executed in all respect with supply of all labors, materials and hire charges of machineries, equipments, tools & plants as per design, drawing, specification and direction of EIC. Major items of work involved are given below:

- Cleaning site including cutting and removing jungles, bushes and shrubs with any kind of uprooting.
- Hire and labor charges for shoring work including necessary close plank walling, framing, Eucalyptus/Jhou bulla piling, strutting etc. or sheet piling with necessary support and bracing where necessary, all complete as per direction of the Engineer-in-charge for foundation excavation.
- Preparation of bed of foundation trenches by ramming etc. as per direction of the EIC.
- Earth work in excavation of foundation trenches or drains, in all sorts of soil including removing, spreading or stacking the spoils within a lead of 75m. as directed including necessary trimming the sides of trenches, leveling, dressing and ramming the bottom, bailing out water as required complete.
- Earth work in filling in foundation trenches or plinth with good earth, in layers not exceeding 150 mm. including watering and ramming etc. layer by layer complete with earth obtained from excavation of foundation or carried earth.
- Filling in foundation or plinth by silver sand in layers not exceeding 150 mm as directed and consolidating the same by thorough saturation with water, ramming complete including supply of sand.
- Dewatering of foundation of allied structure by well point method, swamp pump, deep well pumps

or any other approved method supplied by the contractor including installation, preparation etc. of pump pipe line & equipments, energy charge including supply and carriage of all accessories complete.

→ Supplying of continuous filament, needle punched, 100% poly-propylene UV stabilized non-woven Geo-textile used as a filter in Anti-erosion works as per specification given below including carriage of materials to work site complete.

**Specification:**

**1. Physical Properties:**

- i) Mass per unit Area (ASTMD 5261) - 280 Gms/m<sup>2</sup>
- ii) Thickness (ASTMD 5199) - 2.50 mm.

- i) Tensile strength (Wide width) (ASTMD 4595) - 19 KN/m.
- ii) Grab tensile strength (ASTMD 4632) - 1090 KN
- iii) Trapezoidal tear resistance (ASTMD 4533) - 445 N.
- iv) Rod Puncture Strength (ASTMD 4833) - 550 N.

- i) Permeability (ASTMD 4491) - 0.03 mm./Sec.
- ii) Apparent opening size (ASTMD 4751) - 0.09 mm.

→ Labor charges for placing, spreading and laying Geo-jute/ Geo-textile/ Geo-synthetic filter (manufacturer's specification to be followed) on slope of embankment including preparation of subgrade by excavating necessary trenches, filling earth on slope up-to 7.50 cm. depth, cutting Geo-jute/Geo-synthetic sheet in proper shape and sizes etc. dressing, watering, ramming where necessary complete as per direction of the engineer-in-charge.

→ Making sausage rectangular in section for any length made with trap stone boulders (min. 25 Kg. size) rolled inside with 10 SWG (150mm X 100mm mesh) galvanized wire net caging with proper lapping of minimum 250 mm over splitted bamboo stiffeners at 50cm centre to centre (both ways) tying and sewing with 12 SWG galvanized wire including cost all materials to site, carriage, pitching and laying the sausage including launching under water after preparing the bed to proper slope as per direction of the Engineer-in-charge (Loading, unloading and carriage cost of boulder to be paid separately)

a) Where boats are not necessary

(i) (1.20 X 0.90) Metre

→ Labor charges for dry boulder pitching including preparing sub-grade with necessary earthwork including hand packing, filling up the interstices of boulder with smaller pieces and sand, rough dressing boulders excluding supply and carriage of boulders from quarry to site. (Measurement will be on the finished works).

Hard stone boulder weighing 25 Kg. to 40Kg. Panchami or similar variety.

a) Over Geo-fabric filter.

→	Supply of hard stone boulder of Panchami or similar variety at quarry site (25Kg to 40 Kg.) as per specification delivered at work site including stacking as per direction of EIC.
---	---

→ Making necessary barricading, fixing of caution boards, flags, fluorescent strips, lighting arrangement for works in night, traffic diversion where necessary.

→ Removal of surplus earth or spoils and cleaning the site in all respect.

→ Any other allied and related works to complete construction of Bank Protection Work in all respect.

**9) Land Development with all ancillary, allied and related works at the Sub Station Building Site: 200.0cum**

Land development of the **Sub Station Building Site** is required to raise the level of the site for proper drainage

of rain water and any water from other sources to prevent inundation of the site to maintain accessibility and workability throughout the year. Finish level should be at least 0.6m above the flood level. This item includes supply of carried earth, spreading, ramming and compacting etc.

This work should be executed in all respect with supply of all labors, materials and hire charges of machineries, equipments, tools & plants as per specification and direction of EIC. Major items of works involved are given below:

→ Cleaning site including cutting and removing jungles, bushes and shrubs with any kind of uprooting

→ Dismantling brick masonry, plain cement concrete, reinforced cement concrete etc. and stacking

serviceable materials at site and removing rubbish as directed within a lead of 75.0 m.

→Earth work in filling in compound tank, low land, ditches etc. with good earth, in layers not exceeding 150 mm. including breaking clods and consolidating the same by ramming and dressing with proper leveling and grading complete (a) With carried earth arranged by the contractor from any distance.

→Removal of surplus excavated earth/spoils and cleaning the site in all respect.

→Any other allied and related works to complete Land Development in all respect

## **10) Design, Supply and Construction of Paver Block Topped Internal Road/ Path way at the Sub Station**

### **Building Site:**

**a) 5.0m width Path way over 150mm thick PCC: 50.0 meter**

**b) 2.0m width Path way over 100mm thick PCC: 50.0 meter**

This work should be executed in all respect with supply of all labors, materials and hire charges of machineries, equipments, tools & plants as per design, drawing, specification and direction of EIC. Major items of works

involved are given below:

→Cleaning site including cutting and removing jungles, bushes and shrubs with any kind of uprooting and layout of the work as per approved drawing in relation to the other works or structures and demarcation of land as per direction of the EIC.

→Dismantling brick masonry, plain cement concrete, reinforced cement concrete etc. and stacking serviceable materials at site and removing rubbish as directed within a lead of 75.0 m.

→Earth work in excavation of foundation trenches or drains, in all sorts of including removing, spreading or stacking the spoils within a lead of 75m. as directed. The item includes necessary trimming the sides of trenches, leveling, dressing and ramming the bottom, bailing out water as required complete.

→Bailing / pumping out of any type water from foundation trenches and / or any other sources.

→Preparation of bed of foundation trenches by ramming etc. as per direction of the EIC.

→Earth work in filling in foundation trenches or plinth with good earth, in layers not exceeding 150 mm. including watering and ramming etc. layer by layer complete. (a) With earth obtained from excavation of foundation.

→Filling in foundation or plinth by silver sand in layers not exceeding 150 mm as directed and consolidating the same by thorough saturation with water, ramming complete including the cost of supply of sand.

→Ordinary Cement concrete (mix 1:2:4) with graded stone chips (20 mm nominal size) excluding shuttering and reinforcement, if any, in ground floor as per relevant IS codes. a) Pakur Variety

→Single Brick Flat Soling of picked jhama bricks including ramming and dressing bed to proper level and filling joints with local sand.

→Brick work with 1st class bricks in cement mortar (1:4) (a) In foundation and plinth

→Plaster (to wall, floor, ceiling etc.) with sand and cement mortar including rounding off or chamfering corners as directed and raking out joints including throating, nosing and drip course, scaffolding/staging where necessary (Ground floor). (i) With 1:6 cement mortar a) 20 mm thick plaster

→80 mm thick interlocking designer concrete paver block M-40 grade for medium-traffic zone & utility cuts on arterial roads etc. as per IS: 15658-2006 (over 20-40 mm medium sand bed on 250mm thk. WBM/WMM base course & 250 mm thk. bound granular/ granular sub-base course & filling the interstices of blocks with fine sand by brooming & subsequent watering including cost of sand for sand bed but excluding cost of base, sub-base course & subgrade preparation.) complete as per direction of Engineering-Charge. [Note: Subgrade CBR should not be less than 5] (ii) Coloured Decorative

→Applying Exterior grade Acrylic primer of approved quality and brand on plastered or concrete surface old or new surface to receive decorative textured (matt finish) or smooth finish acrylic exterior emulsion paint including scraping and preparing the surface thoroughly, complete as per manufacturer's specification and as per direction of the EIC. (a) Two Coats.

→Protective and Decorative Acrylic exterior emulsion paint of approved quality, as per manufacturer's specification and as per direction of EIC to be applied over acrylic primer as required. The rate includes cost of material, labor, scaffolding and all incidental charges but excluding the cost of primer.

→Removal of surplus earth or spoils and cleaning the site in all respect.

→Any other allied and related works to complete construction of Internal Pathways in all respect.

**11) Design, Supply and Construction of Masonry Internal Surface Drain Having Inside Width 500mm and Average Depth 450mm Having Both Side Wall Thickness 250mm at the Sub Station Building Site: 1 items**

This work should be executed in all respect with supply of all labors, materials and hire charges of machineries, equipments, tools & plants as per design, drawing, specification and direction of EIC. Major items of works involved are given below:

- Cleaning site including cutting and removing jungles, bushes and shrubs with any kind of uprooting and layout of the work as per approved drawing in relation to the other works or structures and demarcation of land as per direction of the EIC.
- Dismantling brick masonry, plain cement concrete, reinforced cement concrete etc. and stacking serviceable materials at site and removing rubbish as directed within a lead of 75.0 m.
- Earth work in excavation of foundation trenches or drains, in all sorts of soil including removing, spreading or stacking the spoils within a lead of 75m. as directed. The item includes necessary trimming the sides of trenches, leveling, dressing and ramming the bottom, bailing out water as required complete. →Bailing / pumping out of any type water from foundation trenches and / or any other sources.
- Preparation of bed of foundation trenches by ramming etc. as per direction of the EIC.
- Earth work in filling in foundation trenches or plinth with good earth, in layers not exceeding 150 mm. including watering and ramming etc. layer by layer complete. With earth obtained from excavation of foundation.
- Filling in foundation or plinth by silver sand in layers not exceeding 150 mm as directed and consolidating the same by thorough saturation with water, ramming complete including the cost of supply of sand. (B) Do - by fine sand
- Single Brick Flat Soling of picked jhama bricks including ramming and dressing bed to proper level and filling joints with local sand.
- Ordinary Cement concrete (mix 1:2:4) with graded stone chips (20 mm nominal size) excluding shuttering and reinforcement, if any, in ground floor as per relevant IS codes. a) Pakur Variety
- Brick work with 1st class bricks in cement mortar (1:4) (a) In foundation and plinth
- Plaster (to wall, floor, ceiling etc.) with sand and cement mortar including rounding off or chamfering corners as directed and raking out joints including throating, nosing and drip course, scaffolding/staging where necessary (Ground floor). (i) With 1:6 cement mortar a) 20 mm thick plaster
- Neat cement punning about 1.5mm thick in wall, dado, window sill, floor etc.
- Removal of surplus earth or spoils and cleaning the site in all respect.
- Any other allied and related works to complete construction of Surface Drain in all respect.

**12) Arboriculture and Beautification with all ancillary, allied and related works at the Sub Station Building Site: 1 Item**

Arboriculture and beautification of the Sub-Station Building Site should be done in a manner to render good aesthetic view. This work should be executed in all respect with supply of all labors, materials and hire charges of machineries, equipments, tools & plants as per beautification plan, drawing, specification and direction of EIC.

Major items of works involved are given below:

This work should be executed in all respect with supply of all labors, materials and hire charges of machineries, equipments, tools & plants as per design, drawing, specification and direction of EIC. Major items of works involved are given below:

- Cleaning the site including any tape of uprooting and preparation of layout for the work.
- Earth work in excavation of foundation trenches or drains, in all sorts of soil including removing, spreading or stacking the spoils within a lead of 75 m. as directed. The item includes necessary trimming the sides of trenches, leveling, dressing and ramming the bottom, bailing out water as required complete.



- (A) Filling in foundation or plinth by silver sand in layers not exceeding 150 mm as directed and consolidating the same by thorough saturation with water, ramming complete including the cost of supply of sand. (payment to be made on measurement of finished quantity) (B) Do-by fine sand
- Earth work in filling in foundation trenches or plinth with good earth, in layers not exceeding 150 mm.including watering and ramming etc. layer by layer complete. (a) With earth obtained from excavation offoundation.
- Single Brick Flat Soling of picked jhama bricks including ramming and dressing bed to proper level andfilling joints with local sand.
- Ordinary Cement concrete (mix 1:2:4) with graded stone chips (20 mm nominal size) excluding shutteringand reinforcement if any, in ground floor as per relevant IS codes. a) Pakur Variety
- Ordinary Cement concrete (mix 1:1.5:3) with graded stone chips (20 mm nominal size) excluding shuttering and reinforcement if any, in ground floor as per relevant IS codes.
- Reinforcement for reinforced concrete work in all sorts of structures including distribution bars, stirrups,binder setc initial straightening and removal of loose rust (if necessary), cutting to requisite length,hooking and bending to correct shape, placing in proper position and binding with 16 gauge blackannealed wire at every intersection, complete as per drawing and direction. (a) For works in foundationandupto roof of ground floor/upto 4 m (i) Tor steel/Mild Steel I. SAIL/ TATA/RINL
- Hire and labor charges for shuttering with centering and necessary staging upto 4 m using approved stoutprops and thick hard wood planks of approved thickness with required bracing for concrete slabs, beamsand columns, lintels curved or straight including fitting, fixing and striking out after completion of works(upto roof of ground floor)(When the height of a particular floor is more than 4 m the equivalent floorheight shall be taken as 4 m and extra for works beyond the initial 4 m ht. shall be allowed under 12 (e)for every 4 m or part thereof) (a) 25 mm to 30 mm thick wooden shuttering as per decision &directionof Engineer-In-Charge (b) 25 mm to 30 mm shuttering without staging in foundation .
- Brick work with 1st class bricks in cement mortar (1:6) (a) In foundation and plinth
- Plaster (to wall, floor, ceiling etc.) with sand and cement mortar including rounding off or chamferingcorners as directed and raking out joints including a) 20 mm thick plaster (6:1)
- Construction of raised bed for plantation including 250mm thick brick in 1:6 cement sand mortar, rendering plastering in 1:6 cement sand mortar , color wash on all surfaces including earth work in excavation in any kind of soil, back filling the trench and filling the bed with good quality carried earth.
- Construction of Brick gabion 1.50 m internal dia. and 1.20m high with 150 mm deep solid brick band(in 1:6 cement mortar) at base,125 mm thick body of Jeffry brick work set in cement mortar (1:4) and150 mm. deep solid brick band at top in cement mortar 1:6 and cement plaster (1:6) (all faces) includingcolour wash (all surfaces) to the top band and red-oxide or similar approved wash (all surfaces) to theremaining portion.
- Brick edging 75 mm wide around the plantation bed at ground level with picked jhama bricks, laid true to line and level including cutting necessary trench in soil or in hard metalled surface, laying the bricksand repacking the trench (on both side of the digging) with spoils and ramming the same thoroughly
- Supplying and stacking of good earth (adequate for horticulture work)
- Supplying and stacking sludge (adequate for Horticulture work) at site in dry cake form from approveddisposal work site including royalty, all lead and lift etc.
- Spreading of sludge, dump manure/farm yard manure/animal dung manure and good earth in requiredthickness including, tools & plants.
- Supplying and fixing grasses tiles of grass Mexican Carpet/Selection No. 1 Healthy & fresh grasses (size1'x1' or bigger) including watering and maintenance of the lawn for 30 days or more till the grass formsa thick lawn free from weeds and fit for mowing including supplying good earth as required by Engineering-charge.
- Preparation of beds for hedging and shrubbery by excavating 60cm deep and trenching the excavated baseto a further depth of 30cm, refilling the excavated earth after breaking clods and mixing with sludge ormanure in the ratio of 8:1 ( 8 parts of stacked volume of earth after reduction by 20%, one part of stackedvolume of sludge or manure after reduction by 8%), flooding with water, filling with earth if necessarywatering and finally fine dressing, leveling etc., including stacking and disposal of materials declaredunserviceable and surplus earth by spreading and leveling as directed, within a lead of 50m lift upto 1.5mcomplete. This includes supply of labor, tools & plants including materials. Planting hedge plants in tworows at 30cm apart
- Supplying and Planting of different plant / trees (Supplying well grown plants bushy and healthy,

minimum height as specified i.e. exposed height including all leads & lift, carriage, handling, manuring, applying pesticide and fertilizer etc. i) Rangon hi-breed healthy plant. ii) China palm of leaves 4-5 in earthen pots size 25cm and iii) other selected variety.

→ Providing and erecting decorative bamboo fencing including 2(two) coats painting of approved colour and shade around the plantation beds.

→ Removal of surplus earth or spoils and cleaning the site in all respect.

→ Any other allied and related works to complete arboriculture and beautification in all respect.

**13) Survey, Soil Investigation excluding Hydrogeological investigation but including all allied works at the Collector Well, Sub-Station Building site, at the Pier & abutment location for M.S Access Bridge: 1 Item**

This work should be executed in all respect with supply of all labours, materials and hire charges of machineries, equipments, tools & plants as per specification and direction of EIC. Major items of works involved are given below:

→ All tools and plants along with accessories, materials & labours are to be mobilized at the worksites.

→ In addition, boring rig are to be set up and shifted to different borehole points.

→ Three (03) boreholes at each of the three (03) work sites is to be done by any standard method up-to 20.0m depth below ground level / bed level in all kinds of soil for the purpose of collecting disturbed and un-disturbed soil samples.

→ Drilling mud, Bentonite of suitable consistency is to be used to prevent collapse of bore hole.

→ Standard penetration tests are to be conducted at suitable intervals.

→ Soil samples are to be collected from the bore holes

→ The following laboratory tests are to be performed on disturbed / undisturbed soil samples as collected as per standard procedure including tabulation of test results in prescribed proforma as per direction of Engineer-in-Charge. (As per ISI:2720)

- Liquid Limit and Plastic Limit (As per 2720 part V)

- Sieve analysis (as per 2720 part IV)

- Grain Size analysis by sieving as per IS:2720 (Part-IV)

- Grain Size analysis by Hydrometer Method as per IS:2720 (Part-IV)

- Determination of water content as per IS 2720 (Part-II)

- Determination of Specific gravity as per IS 2720 (Part-III)

- Direct shear test as per IS 2720 (Part-XIII)

	<ul style="list-style-type: none"> <li>• Determination of unconfined compressive strength as per IS 2720 (Part-X) of Undisturbed soil</li> <li>• Determination of consolidation parameter test as per IS 2720 (Part-XIV)</li> <li>• Determination of Shear strength Parameters of a specimen tested in Unconsolidated Undrained Tri-axial compression without measurement of pore water pressure as per IS 2720 (Part – XI).</li> <li>• Determination of Safe Bearing Capacity of Soil (SBC)</li> <li>• Any other parameters as may be required.</li> </ul>	<ul style="list-style-type: none"> <li>•</li> <li>•</li> </ul>
<ul style="list-style-type: none"> <li>•</li> <li>•</li> </ul>		

→ All disturbed and undisturbed samples of soil are to be presented to the Office of the EIC

→ The report in three copies giving all relevant information data like site plan, bore log and water table, test result, calculation, discussion, suggestion and recommendation in respect of suitable foundation etc. including determination of silt factor calculation of water way and complete design of foundation including analysis of bearing capacity and settlement in bund are to be submitted to the office of EIC.

**D) COMMISSIONING, TRIAL RUN AND OPERATION & MAINTENANCE**

a) Three-months trial run of entire system under this Tender after completion and commissioning including supply of all accessories, manpower, spares, chemicals and other consumables as and when required is to be carried out. Tenderer will supply all commissioning spares. Cost of such spares is to be included in the financial offer.

All commissioning spares shall be at site before trial run of respective system. In all the cases damaged /defective portion shall be restored / replaced / renewed immediately, with no extra cost.

b) 5(five) year of O&M work of entire system under this Tender after successful completion of three months of trial run including supply of all accessories, manpower, spares / replacements, chemicals and other consumables and when required is to be carried out. Tenderer is to furnish list of spares for 5(five) year O&M on his previous experience. In all cases the damaged / defective portion shall be restored / replaced / renewed immediately at no extra cost.

### **Trial Run and Operation & Maintenance include**

→Opening & closing of all the different dia. sluice valves at different places along the alignment of the rising main daily or as and when required for regulating the supply of water including changing and restoration of gland packing of sluice valves, ball of air valve if required including opening the cap/plug of wash out point or opening the sluice valves including de-jointing flange joints including repairing works and cleaning the pipeline or changing of gate, spindle or liner etc. of sluice valves all complete, restoration works to be done including earth work in the excavation bailing out of water, refilling the excavated earth, taking out of RCC slab or slab cover and re-fixing true to position etc. all complete as per the specification and direction of EIC.

→Periodical cleaning silt from the overhead reservoirs, cleaning washing and disinfecting the same with bleaching powder, including machinery, tools and plants as per direction of EIC complete (Bleaching powder will be supplied by the Agency)

→Periodical cleaning of Clear Water Reservoir is to be done during the period.

→The pipes, specials, etc. under sanitary and water supply arrangement are to be replaced / repaired as and when required.

→The work includes supply of all accessories, manpower, spares, chemicals, and other consumables as and when required.

→Charges for health check-up for water borne disease of the workers deputed in maintenance work (including testing of blood (TC, DC, ESR, HB %), Urine (R/E), Stool (R/E) by registered Medical Practitioner.

→Any other item of work required for successful trial run and operation & maintenance to be taken up as and when required.

## **Specification of Pipeline**

### **1.0 GENERAL**

Laying D.I. pipes (All types & Class) including earth work in excavation in trenches, shoring (if necessary) of adequate width having minimum depth to keep the top surface of pipe 1.00M below of the existing ground level in any kind of soil mixed with boulder, metal crust, concrete pavement, any road sub-grade and its flank etc., dewatering the trenches, preparing the bottom surface of the trenches for continuous bedding including sand filling (if necessary) or over ground installation to cross ditches etc. supported with RCC pillars as & when necessary and fitting, fixing, jointing (all types of joints) valves, specials etc. as per requirement, in position, cutting, chamfering of pipes as required, carriage of materials from departmental store to work site, constructing sluice valve chambers including supply and fitting in position sluice valve of different dia. & supply and fitting in position D.I. Specials as per requirement, filling of the trenches with excavated materials, consolidating the same in layers, permanent road restoration, guarding trenches with temporary bamboo railing for safety where necessary, emergency horizontal auger boring (for roads other than NH and Railway) where necessary, removing the surplus materials from site including all labour charges, tools and plants, hydraulic pressure testing, cleaning and disinfection of pipes etc. complete in all respect as per IS 12288-1987 (latest edition) and instruction of E.I.C.

(Only the D.I. pipes and rubber gaskets will be supplied departmentally. Others materials like M.S. Pipes, Sluice valve, Air Release valve, D.I. Fittings, Mechanical Joints, M.S. Pipe for sharp bend and others location etc., where necessary, will be supplied by agency. The surplus and unused DI Pipe materials are to be returned to store at his own cost.)

## **2.0 LOCATION**

Water Supply Scheme under AMRUT within Burdwan Municipal area as per departmental drawing, Dist.-PurbaBurdwan.

## **3.0 DETAIL SCOPE OF WORKS**

I.The agency has to quote the rate on the basis of quantity of laying as per approved drawing and existingcondition of the site as unit rate diameter wise. The participating agency has to carefully inspect the site with the attached drawing and collect all data for preparation of justified estimate and thereafter evaluation of unit rate against each item of BOQ. The participating agency also includes the cost of all such items in estimating the total cost which is required to complete the work complete in all respect.

II.The work is to be executed as per related IS Specification, Municipal Agreement and other specificationlaid down in the bid. The DI Pipes of different diameter and rubber gaskets will only be supplied by this Municipality. Sluice valve, Air Release valve, D.I. Fittings, Mechanical Joints etc., where necessary, will be supplied by agency.

III.The contract comprises oflaying of Clear Water Rising Main (D.I.Pipes, All types & Class)including all D.I. Specials and laying, fitting, fixing, jointing and all other works incidental thereto asdesired and set-forth in the specification.Bidders are advised to inspect the site before tendering, extra claims on the ground of insufficient data and absence of knowledge about conditions prevailing at site shall not be entertained.

IV.A network drawing is attached with the quotation in .pdf format. The agency has to collect the .dwgformat (AutoCAD format) from the concerned division and plan everything on the drawing i.e., where additional work of shoring, BFS, RCC column, sand filling, Sluice valve and chambers etc. are required. **The whole planning thereof will be uploaded in .pdf format in a folder under Technical bid.** This will be oneof criteria to judge the Technical ability of the participating agency. This will be the basis on which the successful bidder has to submit the details of estimate if asked for before acceptance of bid. The final drawing (6 copies) prepared on the basis of the above will be prepared after issuance of work order and

will be approved by competent authority, if found correct.

**V.**The work has to be carried out on the basis of the approved drawing and part drawing has to be submitted along with each R.A bill submitted by the Contractor.

**VI.** After completion of the work, a completion drawing (6 copies) in suitable scale with position of pipes (diameter wise and its length), specials/fittings, valves issued to him by Department or supplied by them have to be submitted along with final bill. The final bill shall not be paid unless the said stipulation is complied with.

**VII.** Care has been taken to make the uploaded drawing as correct as possible, nevertheless these drawings must be checked thoroughly by the tenderers' who will be held responsible for satisfactory work of the pipe connection with all its details. Any discrepancy noticed should be pointed out before the work is commenced. Under all circumstances, the contractor will be held responsible for the satisfactory completion. In case of any discrepancy between the drawing and the schedule of tender, the decision of the Superintending Engineer will be final and binding.

**VIII.** The works are to be carried out strictly in accordance with approved drawing and specifications supplemented by other detailed working drawings as the Engineer-in-Charge may sign, if necessary, from time to time. For any change, no extra claim will be entertained.

**IX.** The pipes are to be laid as far as practicable along road flanks with least hindrances to the vehicular traffic. The contractors are to obtain the information regarding the layout and precise position of the underground Electric Main, Telephone or other Cables. No responsibilities in this respect will be taken by the Directorate. The contractor will have to cut metal road or bituminous road of any thickness where suitable Road flank is not available and its cost is included in the relevant items of the work.

**X.** The trenches will have to be adequately protected against accidents continuously throughout day and night. Demonstrations of danger signals, red lamps and other signs as may be required at the vintage point and imperative upon the contractors in the interest of public safety.

**XI.** The contractors' will further shore up and support to the satisfaction of the Engineer-in-Charge, all Building Works, Electric Mains, Telephone or Other Cables, Surface Storm Water, Drains, Ditches, Culverts, Water Sources, Water Mains and Other Pipes which may be or likely to be affected or endangered or disturbed by the works, being in the line thereof and continuous thereto.

**XII.**The contractors' will be liable for and make good at their own expenses within a reasonable period of time to be fixed by the Engineer-in-Charge, all damages which may be occasioned to one or combination of items in building, walls, water mains and other pipes by or in consequence of the execution of the works or accident whatsoever, in the event of default (in lapse with respect to the time limit) it shall be lawful for the undersigned to employ other agency to make good the damages at the risk at cost of the contractors' after a 24 hours written notice period has elapsed. The expenditure amount in above situation will be deducted from the bills of agency.

**XIII.**In case of trenches in front of any holding so as to block its passage of communication, the contractors' will have to make for temporary arrangements to remove the difficulties by provision of wooden planks or otherwise and removing the same after the trenches are filled up.

**XIV.**The tenderers will consider the conditions and adjust the extent of liabilities involved and quote their rate accordingly. Since no extra claims will be entertained separately on that account, inspection of sites prior to tendering, therefore, should be done by the tenderer.

Further "Laying of Pipes" shall also include excavation of trenches upto a depth ensuring a minimum cover of one metre over the top of the pipe.

**XV.**Decision of the Engineer-in-Charge in this respect is final. The excavation shall have to be done through any materials (e.g. – soil, premixed road surface, concrete to roads etc.) with shuttering and dewatering as may be required to protect the trenches and facilitate the works during execution. This also includes cutting and removing trunks and roots of trees upto 20mm dia.

**XVI.**Cutting the pipes to sizes (except for damaged ends supplied by the Department, where necessary), lowering and placing them along trenches including laying, fitting and jointing with rubber gasket and / or solvent cement joint and/or D.T. joint as the case may be. Filling the trenches in layers of 15cm, each layer being adequately watered and consolidated. The filling has to be done after completion of the joints and after effecting the hydraulic test as per specification.

**XVII.** After removal of the surplus excavated materials (except road metal) after the trenches have been rammed to the satisfaction of the Engineer-in-charge, if any, serviceable materials such as bricks and stones, ballast and chips, stone-setting, asphalt etc. are available from roads and other road flanks along which the pipes have been laid for restoration of the same, contractor will arrange for stacking these materials properly and separately as per direction of Engineer-in-Charge for which, no extra payment will be entertained in this situation.

**XVIII.**The contractors' rates for laying pipes will also include the cost of all the items of works mentioned with this Clause excepting that for which, a separate item has been provided in the schedule.

**XIX.**In general, the pipes have to be laid below 1 metre from the existing ground level but if 1 metre cushion cannot be maintained anywhere to maintain the hydraulic gradient in the undulating terrain, (+/-) 10 % deviation in respect of such situation will be acceptable.

**XX.**The contractor will provide his own arrangement for every cost, charges or expenses which may be claimed or any person public or private or Government concerned, occurred to the property of life of any such concern or person (as the case may be) by or in consequence of the execution of the said work or in respect of any labour of work, entitled upon said work for which, no extra payment will be allowed.

**XI. PERMANENT ROAD RESTORATION:**

**Restoration of bituminous roads & Concrete roads to be done as per drawing, direction and satisfaction of E.I.C.**

**XXIV. EXCAVATION OF FOUNDATION, FILLING UP TRENCHES:**

Foundation is excavated as per drawing. The depth and width of trenches are properly maintained. The bed of trench is to be properly levelled and rammed. Any water accumulated in the trenches due to sewage or rain water to be dewatered at the cost of contractor. The laying rate includes for excavation in whatever soil and stone, hard or soft, that may be found and breaking through any underground structure surface metalling, pegging and trimming and pumping, if necessary, for removal of water or muddy water, taking out mud keeping the top soil separately or unavailing of surplus materials, tapping and shoring excavated materials, matching temporary installment and maintenance of surface and every other expense in strict conformity with the specification.

The excavated areas around the foundation structure are to be filled up properly to the required levels with the earth obtained from excavation. The filling should be done properly consolidated with Iron Rammer and sprinkling water. The cost of filling up the trenches includes relevant items of work for which, no extra payment will be made.

## **XXV.DEPARTMENTAL SUPPLY OF PIPES AND CARRIAGE:**

The departmental supply of D.I Pipes of different Pipes and rubber gaskets for pipeline will be made from the local Departmental Store. List of materials will be prepared on the basis of the actual requirement duly once set by Engineer-in-Charge so that, least possible materials are left surplus which are to be returned back to local departmental store by the contractor for which no extra payment will be made.

The carriage cost from store to work site has been provided in the respective item of the schedule, for which, no extra payment will be made. The contractor shall check the quality of materials before taking delivery of the same, any subsequent complaint in this respect shall not be entertained.

The contractors' are solely responsible for the safe custody of those supplied materials onwards from the date of issue till the same are used in the work according to the contract and the surplus items are finally handed-over to this Directorate/Department. For any loss or damage occurring during this period, the contractors' will remain responsible and recovery will be made from them as per Rule.

The contractors' at their own cost will supply labours for loading, unloading and stacking the materials as and when required by the Engineer-in-Charge.

No carriage charges will be paid for any carriage within the campus of the work site, for any advance carriage (to relieve cage of the store), double carting if it becomes necessary and return the surplus materials to the Departmental Stores, no extra payment shall be made. The cost of all such carriage has been included and distributed in the relevant items of the bill of quantities.

No claims for extra payment due to any delay of detention, dispute of non-procurement of materials to be supplied departmentally or for any other reason will be entertained.

## **XXVI.RECOVERY OF MATERIALS:**

For loss or damage of the materials supplied by Government or non-returning of surplus materials, recovery will be made from the contractor at the highest of the following rates :-

.

Fifty per cent in excess of departmental stock rate or the rate at which Municipality buy the material from agency at the time of recovery of value.

Ten per cent in excess of market rate at the time of recovery of value. Decision of the Executive Engineer/E.I.C. concerned in respect of market price is final and bindings.

The contractors' should carefully examine the materials supplied from Govt. Store regarding its quality and suitability. No complaint in this regard will be entertained once the materials have been supplied to and received by the Contractors.

## **XXVII.DEPARTMENTAL MATERIALS AND COST:**



All the materials except D.I. Pipes, and DT/Mechanical Joints, Rubber Gaskets have to be supplied by the contractor. The aforesaid materials will be supplied by the Department free of cost as non-recoverable items.

#### **XXVIII.TIME OF COMPLETION:**

The works for pipe line shall be completed in all respect by the contractors' within 180(One hundred and eighty) days.

In the event of work being not completed within this stipulated period, the contractors' will be liable to pay a penalty as Clauses of Municipal Form K through which the tender will be accepted.

The contractor will show satisfactory cause for delay in starting work if the works are not started within 10(ten) days from the date of issue of work order. Otherwise, the contract will be terminated. The contractor will accordingly, prepare a time bound programme of execution with regard to all the items of work set-forth in a schedule and submit the same to the undersigned within 7(seven) days' from the date of work order.

For unsatisfactory progress of work, it will be the option of the undersigned/E.I.C. to withdraw the works out of the contractors' and to get the balance works done through any other agency at the risk and cost of the contractors'.

In case of recurrence of unsatisfactory progress, the undersigned/E.I.C. shall have the power to rescind the contract and to impose such penalties as have been specified in the Municipal Form K. The contractor may further be debarred from tendering for works under this Directorate.

Before starting the work, the contractor shall submit a target of progress schedule showing the different portions of work, he expects to complete against stages of time.

#### **XXIX.SITE ORDER BOOK:**

The contractor will produce Site order book at site before commencement of the work duly numbering the page herein shall be recorded the orders, instructing comments, sketches etc. as may be issued at site by the undersigned / Engineer-in-Charge or his authorized representative from time to time. The contractor also will comply with such order, instruction, sketches etc. and will maintain the site order book till the contract is fulfilled and will be required to produce the same on demand by the Engineer-in-Charge.

The site order book shall be a bound register full scape size of fifty pages in triplicate duly marked two pages in each unit of three should have perforation beside, so as to be easily detachable.

The contractors' or authorized representative (to be categorical named by the contractors') must sign any such orders, instructions, comments and sketches issued as a token acceptance in all three pages of the

Site Order Book.

**XXX.ACCIDENT OR INJURY TO WORKMEN:**

The Employer shall not liable for or in respect of any damages or compensation payable at law in respect or in consequence of any accident or injury to any workman or other; person in the employment of the Contractor or any sub-contractor, have and except any accident or injury resulting from any act or default of the employer, his agents, or servants. The Contractor shall indemnify and keep indemnified the Employer against all such damages and compensation, save and except as aforesaid and against all claims, proceedings, costs, charges and expenses whatsoever in respect thereof or in relation thereto.

**Bidder is responsible to extract water( 45.46 MLD) from river Damodar and deliver to WTP site considering 20hrs.**

**4.0 SPECIFICATION OF DIFFERENT ITEM OF WORKS TO BE EXECUTED**

**a)** Laying D.I. pipes (All types & Class of different diameters) with specials including earth work in excavation in of adequate width as per relevant IS Code having minimum depth to keep the top surface of pipe 1.00M below of the existing ground level in any kind of soil mixed with boulder, metal crust, concrete pavement, road sub-grade and its flank etc., in position and carriage of materials from departmental store to work site, filling of the trenches with excavated materials, consolidating the same in layers, removing the surplus materials from site including all labour, tools and plants etc.

( Only the pipes and rubber rings, will be issued departmentally. The surplus and unused materials are to be returned to store at contractor's own cost.)

**b)** Laying of C.I. / D.I pipes & specials over brick or concrete pillar or wall upto height of 2m above ground level aligning assembling etc. all complete including cost of all sal-ballah staging, bamboo scaffolding tools & plants specials for hoisting and positioning etc. all complete as per specification and direction of E.I.C.

**c)** Cutting cast iron/D.I. (all types) by chisel/Hacksaw including rendering the surface smooth to make itsuitable for rubber gasket/ rubber ring etc. complete as per direction of EIC. (for old line only).

**d)** Chamfering the spigot end of the C.I./D.I pipes for using in Tyton joints line or otherwise by means of electric grinder set at site as per directionof E.I.C

**e)** Cleaningthroughly the inner surface of pipe line including special & valves by flushing with water & subsequently disinfection of the same pipe line by flushing again with water containing bleaching powder resulting in residual chlorine not less than 10 mg / Hr. after 24 hours of such filling including laboratory testing of water sample obtained from disinfected pipe line & disposal of water from the pipe line after completion of the work. The rate is including of cost of requisite water to be arranged by the Contractor.

**f)** Supplying & delivery at working site CIDF sluice valve conforming to IS 14846-2000 (ISI marked), with latest amendment, including stacking and inclusive of Departmental inspection, packing charges, all taxes and duties as applicable and payable, Flanged drilled as per IS 1538-1993 with latest amendment all complete along with installation of the same as per direction of E.I.C.

(Approved make : Kirlosker/IVC/L&T/VAG/M&P/Upadhyay)

Class PN 1.0 with cap. (Sluice Valve to be supplied by agency)

**g)** Making flange joint to D.I pipes and specials and valves including dewatering of trenches, tools & plants, labour etc as per specification and instruction of E.I.C .

**h)** Hydraulically testing of different types of pipes in sections for a head of water not less than 1/2 (Half ) the pressure recommended by I.S or corresponding pipe materials whether the gauge pressure will remain static for 30 minutes by filling water including supply of necessary equipment's such as generator sets, pumps gauges etc. All complete as per specification and instruction of E.I.C. [Water have to be arranged by the bidder himself and whole testing procedure will be accordance with as per IS : 3114 - 1965]

**i)** Hire and labour charges for 75 mm dia bamboo railing on Jhau / Eucalyptus or other approved timber / bamboo posts 1.4 m above GL and 0.6 m below GL including tying strongly with coir ropes and boring holes for posts in any soil/ concrete surface / Bituminous surface packing the sides etc. including cost of restoration to the damages of the ground to its original condition as per direction of EIC after removing barricade. 75 mm dia bamboo railing and 100 mm dia bamboo posts @1.4 mtr apart. railing with 3 rows.

**j)** Dismantling all type of masonry including cement concrete, stacking serviceable materials at site and removing rubbish as directed within a lead of 75m in ground floor including roof.

**k)** Cutting sub -grade of road (concrete bituminous carpeting & consolidated Ballast/brick soling & other sub-grade materials by means of chisels/Hammer other equipments ( for trenches & laying of pipe line.)

**l)** Emergency horizontal road crossing by Auger-boring including boring charge, pipe laying and jointing, making barricades, lighting arrangement etc. all complete as per direction of E.I.C for 100 mm dia to 500 mm dia pipes. (Including State Highways, National Highways and Railways crossing).

**m)** Construction of sluice valve chamber as per drawing supplied by concerned division or standard drawing given by contractor and approved by E.I.C with brick work in cement mortar (6:1) over 15 cm. of WCC (6:3:1) with supply of approved quality (Heavy type) C.I surface box embedded in 100mm thick removable slab in (4:2:1) including fitting, fixing and overhauling and instruction of E.I.C (Valves will be supplied by Agency).

**n)** Installation of CI Bolted collar as per IS 13382-1992 with latest amendment or end cap up to date

including all taxes & other incidental charges what so ever, carriage, loading unloading & stacking at working site.

**o)** Hire and labour charges for shuttering with centering and necessary staging upto 4 mtr. using approved stout props for and thick hardwood planks of approved thickness with required bracing for concrete slabs , beams and columns ,lintels curved or straight including fitting , fixing and striking out after completion of works (upto roof of g.f), as per drawing, specification & direction of E.I.C.

**p)** Ordinary cement concrete ( mix 1:2:4) with graded stone chips (20 mm nominal size ) excluding shuttering and reinforcement if any in ground floor as per relevant IS Codes.

a) Pakur variety. In ground floor

**q)** Reinforcement for all reinforced concrete work in all sorts of structures including distribution bars, stirrups, binders etc. including supplying of rods, initial straightening and removal of rust (if necessary), cutting to requisite length, hooking & bending to correct shape ( if necessary) placing in proper position & binding with 16 gauge black annealed wire at every intersection etc. complete as per drawing & specification including cost of wire.

**r)** Ordinary cement concrete ( mix 1:1.5:3) with graded stone chips (20 mm nominal size ) excluding shuttering and reinforcement if any in ground floor as per relevant IS Codes.

a) Pakur variety. In ground floor

**s)** Single Brick Flat Soling of Picket Jhama bricks including ramming & dressing bed to proper level & filling joints with powder earth or local sand.

**t)Restoration of all types roads complete as per direction of and satisfaction of E.I.C.**

#### **4.0 Limit of Contract**

The limit of contract starts from preparation of complete drawing of respective zone showing diameter and length of pipe, Valve etc. and after approval of same by competent authority proper execution according to specification and after completion of the job preparation of final drawing and submission of the same to competent authority. In between the above, all the works required for successful completion of the component are in the scope of the above work.

**SCOPE OF WORKS & TECHNICAL SPECIFICATIONS FOR**  
**ELECTRICAL AND MECHANICAL INSTALLATION**

THE TENTATIVE ELECTRO-MECHANICAL EQUIPMENT LIST IS MENTIONED IN THE BOQ. HOWEVER, SPECIFICATION OF EQUIPMENT TO BE FINALIZED DURING DETAILED ENGINEERING BASED ON THE SITE / PROCESS REQUIREMENT AND ACCEPTANCE BY THE EIC.

**The Chairman/ Administrator**

**Burdwan Municipality**

## **SECTION- E**

### **SCHEDULE OF WORK**

Survey, Planning, Design, Supply, Delivery, Erection, Construction, Commissioning and Completion in all respect all Civil and Electro- Mechanical Works including all others allied, related and enabling works for 2 nos. 22.73 MLD Capacity each Radial Collector Wells With Pump House, Access & Pipe carrying Bridge at Damodar including HT Sub Station Building at Damodar River in between Belkash&Zuzuty village, protection work at river bank, Raw Water Rising Main including construction of Pipe carrying Bridge on Banka & DVC Canal &Parmanent Road restoration works from Radial Collector Wells to WTP as recommended Hydro-geological investigation report of Jadavpur University along with all manifold line and necessary valves and accessories, and construction of boundary wall, approach road, drain at Sub-station area with necessary Civil, Electrical (according to Indian Electricity rules), Mechanical & all other allied works related for pump house with necessary approval from respective Competent Authority including lightening within yard, pump house, walkway and internal illumination complete in all respect on turnkey basis as per satisfaction of the department. After satisfactory completion and commissioning, 3 (three) months trial run, necessary training of maintenance staff & thereafter (subsequently) 5 (five) years operation and maintenance with security /guarding arrangement under AMRUT Project.

<b>Sl. No.</b>	<b>Description of Work</b>	<b>Quantity</b>
1.	Design, supply and construction of Collector well having inner diameter of 6m min. and overall depth of 32m of which min 20m is below river bed level and provided with minimum 24 nos. of (40+10)m long and 400mm diameter of radial stainless steel ribbed case type strainers ineach of the 2 layers 3m apart distance by jack pushing method and desandingoperationalong with other necessary accessories including all alliedworks, complete in all respect with all labour& materials as per scope of work,specification, Tender Document & direction of E.I.C.	2 Nos.
2.	Design, supply and construction of Access Bridge (pipe carriageway) minimum 3.00m width to carry suction / delivery pipe up to the bank of the river with suitableRCC structure supported on column & adequate RCC foundation / pilesfoundation including all allied works, complete in all respect with all labour&materials as per scope of work, specification, Tender Document & direction ofE.I.C.	
a	3.00 m wide Access Bridge	354m. & 535m. at Damodor , 100m. at Bakakhal& 100m at DVC Canal.
4.	Design, supply and construction of 110 m2 Size Pump House over collector wellfor accommodating Vertical Turbine pumps for delivering water from well toCWR including all allied works, complete in all respect with all labour& materials as per scope of work, specification, Tender Document & direction of E.I.C.	1 No.
5.	Design, supply and construction of Sub-Station building of size of 30m X 5m	1 No.

	including plinth protection, surface drain and all allied works near collector well, complete in all respect with all labour & materials as per scope of work, specification, Tender Document & direction of E.I.C.	
6.	Design, supply and construction of Office cum Go down of 65m <sup>2</sup> area with water supply and sanitation arrangement including plinth protection, surface drain and all allied works at the Sub Station Building Site near collector well, complete in all respect with all labour & materials as per scope of work, specification, Tender Document & direction of E.I.C.	1 No.

7.	Design, supply and construction of Guard Room of 4.0 mx3.5m size including plinth protection, surface drain and all allied works at the Sub Station Building Site near collector well, complete in all respect with all labour & materials as per scope of work, specification, Tender Document & direction of E.I.C.	1 No.
8.	Design, supply and construction of Boundary Wall including all allied works at the Sub Station Building Site near collector well, complete in all respect with all labour & materials as per scope of work, specification, Tender Document & direction of E.I.C.	175.0m
9.	Laying DI(K9) Raw Water Rising Main from Collector Well to the River Bank on the Access Bridge including construction of valve chamber, thrust blocks, anchor blocks, hydraulic testing, cleaning washing and flushing with supply, fitting and fixing all types of DI specials including all allied works, complete in all respect with all labour & materials (except DI pipes which will be supplied departmentally free of cost) as per departmental drawing, scope of work, specification, Tender Document & direction of E.I.C.	1 Item
	a) Raw Water Rising Main on Access Bridge from Collector Well to River Bank: i) 600 mm dia. DI(K9) : b) River bank to WTP : 800 mm dia. DI (K/9):	1550.0 m 9000 m,
10.	Design, supply and providing Bank Protection by boulder sausage work on both upstream and downstream of abutment of the access bridge for the collector well including all allied works, complete in all respect with all labour & materials as per scope of work, specification, Tender Document & direction of E.I.C.	200.0m
11.	Land Development at the Sub Station Building Site near Collector Well by Earth work in filling in compound, tank, low land, ditches etc. with good earth, in layers not exceeding 150 mm. including breaking clods and consolidating the same by ramming and dressing complete. With carried earth arranged by the contractor within a radius of 3 km. complete in all respect with all labour & materials as per scope of work, specification, Tender Document & direction of E.I.C.	100.0 m <sup>3</sup>
12.	Design, supply and construction of Paver Block Topped Internal road/ Path way including all allied works at the Sub Station Building Site near Collector Well, complete in all respect with all labour & materials as per scope of work, specification, Tender Document & direction of E.I.C.	
	a) 4.0m width Path way over 150mm thick PCC	50.0m
	b) 1.5m width Path way over 100mm thick PCC	50.0m

13.	Design, supply and construction of Internal Surface drain of brick masonry including all allied works at the Sub Station Building Site near Collector Well, complete in all respect with all labour & materials as per scope of work, specification, Tender Document & direction of E.I.C. a) Inside width 500mm and average depth 450mm having both side wall thickness 250mm	50.0m
14.	Arboriculture and Beautification including all allied works at the Sub Station Building Site near Collector Well, complete in all respect with all labour & materials as per scope of work, specification, Tender Document & direction of E.I.C.	1 Item

15.	Soil Investigation for determination of safe bearing capacity and other relevant parameters of soil for Collector Well, Access Bridge and Sub-Station Building (3 sites @ 3 nos. bores. per each = 9 nos. bore) including all allied works, complete in all respect with all labour & materials as per scope of work, specification, Tender Document & direction of E.I.C.	1 Item
16.	Trial Run of entire system under this Tender after completion and commissioning including supply of all accessories, manpower, spares, chemicals and other consumables as and when required including periodical cleaning of Collector Well, complete in all respect with all labour & materials as per scope of work, specification, Tender Document & direction of E.I.C.	3 Months
17.	O&M work of entire system under this Tender after successful completion of three months of trial run including supply of all accessories, manpower, spares / replacements, chemicals and other consumable as and when required including periodical cleaning of Collector Well, complete in all respect with all labour & materials as per scope of work, specification, Tender Document & direction of E.I.C.	60 Months

**Note:**

1. The components / items involved in the work will consist of, but not limited to broadly the above and shall be carried out by the contractor as per scope of works, specification, drawing, conditions of contract, additional conditions of contract, other documents and direction of EIC.
2. Integration of works wherever required shall be made by the contractor as per standard civil Engineering practices for best use of the systems as contemplated as per direction of EIC.
3. No material except DI pipes will be supplied departmentally unless otherwise mentioned; contractor has to procure all materials from the approved Vendors of the department.
4. Haulage path / temporary approach road for carriage of materials / spoils to/from site shall be arranged by the contractor at his own cost for uninterrupted / smooth progress of work.

**The Chairman/ Administrator**

**Burdwan Municipality**



## **SECTION - F**

### **PROCESS DESCRIPTION AND DESIGN PARAMETERS**

#### **1.0 GENERAL**

Directorate of Municipal Engineering, Govt. of West Bengal intends to set up one Piped Water Supply Scheme of Burdwan Municipality, District: Burdwan. The Scheme shall be provided with Collector Well with Pump House, Access Bridge, Raw Water Rising Main, Clear Water Reservoir, High Lift Pump House, Clear Water Rising Main, 10 Nos. Zonal Over Head Reservoirs, Distribution System in all 10 Zones, Sub-Station Buildings, Chlorine Rooms, Office cum Godowns, Raw Water and Clear Water Pumping Machineries and other allied Civil and Mechanical/Electrical Works. All Civil Works including all Allied, Related and Enabling Works for Collector Well with Pump House, Access Bridge, Sub Station Building, Raw Water Rising Main from Collector Well to River Bank etc. are included in this Tender. Rest of the Works will be executed by inviting separate Tenders.

#### **2.0 PROCESS DESCRIPTION AND DESIGN PARAMETERS**

The source of water of the scheme is sub surface water of river Damodar. Sub surface water will be abstracted through Collector Well. Sub surface water thus abstracted will be pumped into a Clear Water Reservoir (CWR) at the Head Work Site through suitably designed DI (K9) raw water rising main and raw water high lift pumping machineries. Raw water will be treated by chlorination only to make it potable. As the source of water is subsurface water of river Damodar, no other treatment is required. From the CWR, treated water will be pumped into Zonal Over Head Reservoirs (OHRs) through suitably designed DI (K9) Clear Water Rising Main and Clear Water High Lift Pumping Machineries. From the Zonal OHRs water will be supplied to beneficiaries through adequately designed UPVC distribution System through house connections and Street Stand Posts. The design, manufacture, construction, installation and performance of the System and equipments supplied under this tender shall comply with the requirements of Manual on Water Supply and Treatment published by the Expert Committee of Central Public Health & Environmental Engineering Organization (CMEDEO), Govt. of India and relevant IS Codes of Practice. However, following parameters should be considered for the design of different units.

#### **1.0 RCC Collector Well:**

The Source of water of the Piped Water Supply Scheme for Burdwan Municipality is subsurface water of river Damodar. RCC Collector Well will be constructed on the river bed of river Damodar at Bijuri Mouzas, Block: Sainthia for abstraction of subsurface water. Parameters to be considered for design purpose are:

a) Number of Collector Well and Pump house	:	2(two) Nos.
b) Capacity of Collector Well	:	22.73 MLD
c) Pumping Hours	:	20 Hours.
d) Inner Diametre of Collector Well	:	6.0 m
e) Overall Depth of Collector Well	:	32.0 m
f) Depth below River Bed Level	:	20.0 m Min.
g) Height above River Bed Level	:	6.0 m
h) Entrance velocity of water in the slots of radial strainers	:	0.004 m/s
i) Diameter of stain less steel strainer	:	400 mm (min)
j) No. of Strainer	:	24 Nos. (min)

k) Length of each strainer	:	40.0 m (min)
l) No. of layers of strainers	:	2 layers at 3.0 m (min) apart
m) Material of Construction (MOC)	:	Stainless steel

Intermediate working platform, manholes, rungs, railing, stair etc. shall be provided as per requirement and standard construction practice. Suitable level indicator is to be provided.

### 2.0 MS Access Bridge:

M.S Access of Bridge with necessary abutments, piers, columns supported on RCC/Pile foundation, walkway and railing etc. will be constructed for access to the Collector Well as well as carrying raw water rising main from Collector Well to river bank. Parameters to be considered for design purpose are:

a) Number of Access Bridge	:	2(two) Nos.
b) Width of Access Bridge	:	3.0 m
c) Length of Access Bridge	:	534m. & 354m, 100m & 100m
d) Material of Construction (MOC)	:	RCC and M.S

Walkway, railing, stair etc. shall be provided as per requirement and standard construction practice. M.S gate with locking arrangement is to be provided.

### 2.5 RCC Framed Single Storeyed Pump House Over Collector Well:

Raw Water High Lift Pumps, Mechanical & Electrical Equipments and Accessories will be accommodated in one RCC Framed Single Storeyed Pump House Over Collector Well. Parameters to be considered for design purpose are:

a) Number of Pump House	:	2(two)
b) Plinth Area of Pump House	:	110.0 m <sup>2</sup>
c) Working Floor level	:	At top of Collector Well
d) Height of Pump House	:	5.5 m above working floor up-to bottom of roof beam.
e) Regular Stair for access to intermediate operator floor	:	1 (One) No.
f) Height of parapet wall	:	450 mm (Min)
g) Material of Construction (MOC)	:	RCC frame with brick panel

Walkway, railing, stair etc. shall be provided as per requirement and standard construction practice. M.S gate with locking arrangement is to be provided.

### 4.0 RCC Framed Single Storeyed Sub-Station Building:

RCC Framed Single Storeyed Sub-Station Building will be constructed at the Sub-Station Building Site near Collector Well for making Power Supply arrangement. Parameters to be considered for design purpose are:

a) Number of Sub-Station Building	:	1 (one)
b) Plinth Area	:	150 m <sup>2</sup>
c) Plinth level	:	600 mm above FGL
d) Floor Height	:	4.5 m from plinth level up-to bottom of roof beam.
e) Cable Trench with curb angle and insert plate	:	1 item as per requirement.
f) Height of parapet wall	:	450 mm
g) Material of Construction (MOC)	:	RCC frame with brick panel.

Walkway, ramp, railing, stair etc. shall be provided as per requirement and standard construction practice. M.S Rolling Shutter with gear operation and locking arrangement is to be provided.

### 5.0 RCC Framed Single Storeyed Office Cum Godown:

RCC Framed Single Storeyed Office cum Godown will be constructed at the Sub Station Building Site. Parameters to be considered for design purpose are:

a) Number of Office Cum Godown	:	1 (one)
b) Plinth Area	:	65.0 m <sup>2</sup>

c) Plinth level	:	600 mm above FGL
d) Floor Height	:	3.3 m from plinth level up-to bottom of roof.
e) Height of parapet wall	:	450 mm
f) Material of Construction (MOC)	:	RCC frame with brick panel.

### 6.0 RCC Framed Single Storeyed Guard Room:

RCC Framed Single Storeyed Guard Room will be constructed at the Sub Station Building Site. Parameters to be considered for design purpose are:

a) Number of Guard Room	:	1 (one)
b) Plinth Area	:	14.0 m <sup>2</sup>
c) Plinth level	:	600 mm above FGL
d) Floor Height	:	3.3 m from plinth level up-to bottom of roof.
e) Height of parapet wall	:	450 mm
f) Material of Construction (MOC)	:	RCC frame with brick panel.

All doors of Pump House, Sub- station Building, Office cum godown and Guard Room etc. should be made with M.S frame and M.S Sheet / Aluminum. All windows should be aluminum. Windows are to be provided with M.S Grill. 2.5 m x 3.5 m rolling shutter with gear should be provided. M.S Railing, Ramp etc. should be provided where necessary.

### 7.0 RCC Framed Boundary wall

RCC Framed Boundary wall will be constructed at the Sub Station Building Site to prevent entry of trespassers and cattle for safety of the site. The following parameters should be considered for design purpose.

a) Height of Boundary wall	:	2.0m above FGL
b) Length of Boundary wall	:	175.0 m
c) Minimum Size of Column	:	250 mm x 250 mm
d) Column Spacing	:	2.5 m c/c
e) Tie Beam	:	At two suitable locations
f) Brick work	:	125 mm thick in 1:4 cement mortar with 1st class bricks
g) Foundation depth (min)	:	1.2 m below EGL
h) Gate	:	3.5 m wide M.S Sheet Gate
i) Cattle catcher with drain	:	To be provided at the main entrance.
j) Material of Construction (MOC)	:	RCC frame with brick panel.

All the above data and information may vary and should be verified from the department before actual design. Further data / information required will be as per DPR of the PWSS, CMEDEO manual on Water Supply and Treatment and relevant I.S codes

### Structural Design of Collector Well, M.S Access Bridge, Pump House and Sub-Station Building and other components.

Collector Well, M.S Access Bridge, Pump House, Sub-Station Building, Office cum godown, Guard Room, Boundary wall and other Structures should be designed and constructed as per IS: 456 - 2000, IS: 3370, I.S:800 and other relevant I.S Codes with latest amendment, guidelines and construction practice in vogue. Following parameters shall be considered in general for structural design and construction of different components.

#### Safe Bearing Capacity of Soil:

Safe Bearing Capacity of Soil may be adopted as **7.5 MT/Sqm**. If contractor's soil test results show SBC value is less than **7.50 MT / Sqm**, the design is to be carried out with that soil test report, for which no extra cost shall be paid by MEDDT to the contractor. However, if the soil test results show SBC value greater than **7.50 MT / Sqm**, the design may be based on same.

#### Concrete Grade:

–PCC: 1:2:4

–RCC: M30 for water retaining structure & M25 for other important structures and M20 for ordinary construction. M30 and M25 grade concrete should be design mix concrete and cement content should not be less than 500 Kg/Cum. M20 grade concrete should be nominal mix concrete.

#### Steel Grade:

–	Reinforcement: HYSD Fe500 as per I.S 1786:2008
–	Structural Steel: M.S Rolled Section (Solid)
<b>Brick Work:</b>	

<ul style="list-style-type: none"> <li>-</li> <li>-</li> </ul>	<p>250 mm thick Brick Work in foundation, plinth and super structure in 1:6 Cement mortar</p> <p>125 mm thick Brick Work in super structure in 1:4 Cement mortar</p>
--	--

**Plaster:**

<ul style="list-style-type: none"> <li>-</li> <li>-</li> <li>-</li> </ul>	<p>Plaster to wall, beam, column, walking platform, with cement mortar</p> <p>1:6, Plaster on water retaining face with cement mortar 1:4</p> <p>Ceiling plaster with cement mortar 1:4</p>
---	---

- i) With 1:6 cement mortar
  - a) 20 mm thick on rough surface of brick work
  - b) 15 mm thick on plumbed surface of brick work
- ii) With 1:4 cement mortar
  - a) 10 mm on vertical concrete surface, ceiling of roof and chajja.
- iii) With 1:4 cement mortar
  - a) 20 mm thick on water retaining face

-

**Brick:**

-1st class bricks should be used.

**Form Work:**

-Steel / 12 mm thick ply board should be used

**Stone Chips:**

-Pakur variety well graded stone chips should be used.

**Sand:**

-Coarse and clean sand should be used for RCC work.

-Medium and clean sand should be used for brick masonry and plaster.

**MATERIAL AND SERVICES**

The materials and services for the civil/structural work shall include but not be limited to the following:

- a. Earthwork in excavation and backfilling for foundations, underground structures etc. and removal of surplus earth shall be done as per direction of the Employer.
- b. Dewatering of ground water/subsoil water and disposal of rain water shall be done properly.
- c. Compacted sand filling below foundations to achieve the required safe bearing capacity of soil shall be done if required and as per direction of EIC.
- d. Soling and sub-grading work shall be done for all foundations and flooring.
- e. RCC bored cast-in-situ piles shall be provided for foundation work for any structure where required.
- f. Reinforced concrete works shall be done in foundations, columns, beams, floors, slabs, on ground, overhead and underground tanks Super structures and other water retaining structures etc.
- g. Steelwork shall be done in superstructure including platforms, walkways, stairs, ladders, handrails, pipe supports, pipe bridges etc.
- h. All MS inserts, curb angles, channels, rails, MS and GI pipes, pipe sleeves, pipe inserts with puddle flanges, MS rungs etc. for embedding in permanent concrete or masonry work.
- i. All masonry work in sub-structures and super-structures except water retaining structure.
- j. All gates, rolling shutters, ventilators shall be of MS. Steel shutter should be perforated with latest design as per specification of INDO- GERMAN PRODUCT LTD, CHENNAI or similar make.
- k. All collector pipes and down comers shall be done for adequate roof drainage.
- l. All exposed concrete surfaces shall be provided with rendering and painting.
- m. All finishing work for floor, wall and roof to give proper smooth surface.
- n. All finishing and painting work shall be carried out to masonry and concrete structures, etc.
- o. All painting shall be done in steelwork and woodwork.

- p. All buildings/structures shall be provided with apron and peripheral drains.
- q. Adequate water storage tank for drinking, sanitary and plumbing arrangement shall be provided with proper water supply, sanitary and plumbing fixtures etc.
- r. All water supply, soil, waste and ventilation pipes, fittings etc. shall be done as per specifications and direction of EIC.
- s. All electrical appliances and gazettes shall be provided for all rooms and outside yard if covered under scope of work.
- t. Test for water tightness for water retaining structures shall be conducted as per norms.
- u. The items of works and their details which are not covered by this specification shall be carried out as per the relevant sections of specification of P.W. Dept. /MED Dept, Government of West Bengal, & relevant IS Code.

## **2.0 Load Conditions**

2.1 For the design of buildings and structures, dead, imposed and wind load condition shall be according to the latest edition of IS:875. Seismic load shall be considered according to the latest edition of IS:1893.

2.2 While designing structures and foundations either the effect of seismic forces or wind load, whichever produce the worst effect, shall be considered along with the usual load combinations. In the design, due allowance for impact, vibration, inertia loading etc. as secondary effect or live loads vibration, inertia loading etc. as secondary effect or live loads shall be taken into account. In addition, due allowance in load calculation of any equipment as per the equipment manufacturer's data and recommendation shall be considered.

## **2.5 Basic Considerations for Structural Design**

3.1 Codes of Practices Design and construction of all structures, buildings and foundations shall conform to the latest edition of the following codes (Latest Edition) :

- a) Loading Standards ..... IS:875
- b) Earthquake Design ..... IS:1893 & 4326
- c) Reinforced and Plain Concrete... IS:456
- d) Pre-stressed Concrete ..... IS:1343
- e) Structural Steel ..... IS:800
- f) Tubular Structures .... IS:806 & IS:1161
- g) Reinforcement Mild Steel... IS:456 & 432  
Ribbed TOR steel. .... IS:1786 & 1139
- h) Foundations ..... IS:1080 & IS:2950
- i) Pile Foundation & Machine Foundation..... IS:2911 & 2974
- j) Water Retaining Structures ..... IS:3370
- k) National Building Code of India ..... SP:7

### **4 Design of Structures and Foundations**

4.1 All designs shall be made as per the latest version of the relevant Indian Standards.

4.2 The design of reinforced concrete in technical buildings/structures and foundations other than water retaining structures shall be made according to the provisions of IS:456 adopting "Limit State" or "Working Stress" method. But design shall be consistent throughout.

4.3 The design of water retaining structures shall be made accordingly to the provision of IS:456 and IS:3370 adopting "working stress" method.

4.4 Reinforced concrete shall be of minimum grade M25 (Design mix) for all types of important structures and foundations (including equipment foundations) and M20 for other structures except water retaining structure.

4.5 The design of water retaining structures shall be made according to the provisions of IS:3370.

4.6 All underground/above ground (fully or partly) water retaining tanks or structures shall be of RCC construction of design mix properly adopted to impart proper strength, density, workability, water tightness and durability. Concrete shall be of minimum grade M30 (design mix) with minimum cement content of 500 kg/cu m. in the tank proper and M25 (design mix) with minimum cement

content of 500kg/cu m in rest of the part. In addition to this 25 mm thick plaster (1:3) admixture with approved quality waterproofing compound shall be provided on water retaining faces. 10 mm thick plaster (1:4) admixture with approved quality water proofing compound to be provided below roof slabs of water retaining structure.

Water retaining structure shall be a designed as uncracked section as per IS:3370. These will be designed considering liquid up-to full height of wall irrespective of provision of any overflow arrangement. Windloads on overhead tanks/ tall structures shall be designed as per provision of IS: 875. For design purpose, ground water level shall be considered at finished ground level.

4.7 The pipes and fittings which are to be built into the underground walls and floors of structures shall be built in as the work proceeds and plugged. Great care shall be taken to ensure that the joint is watertight. All pipe inserts required for tanks and other underground structures shall be provided with puddle flanges. 4.8 The design of structural steelwork shall be as per IS:800.

4.9 For all other items like brickwork, sheeting, flooring, doors, windows, roof drainage, painting, waterproofing etc. with all other miscellaneous items shall be as per the relevant Indian Standards.

4.10 Foundations for structures and equipment shall be proportioned to resist the worst conditions of loading and shall be generally designed as per the provisions of the latest revision of IS:1904.

4.11 The depth of foundation shall be determined based on loading on foundation, safe bearing capacity at the founding level, constructional and technological requirements. The maximum allowable bearing pressure for the design of foundations may be adopted as 7.5 MT/Sqm. If contractor's soil test results show SBC value is less than 7.50 MT / Sqm, the design is to be carried out with that soil test report, for which no extra cost shall be paid by MEDD to the contractor. However, if the soil tests results show SBC value greater than 7.50 MT / Sqm, the design may be based on same.

## **5.0 Piling**

5.1 General Piles shall generally be bored, cast-in-situ, reinforced concrete type and shall conform to the latest revision of Indian Standard Code of Practice for Design and Construction of Pile Foundations, IS:2911 (Part I/Sec 2). Other relevant codes, standards, manuals etc. published by the Bureau of Indian Standards, Central Public Works Department, Public Works Department/PWD(Roads) of Government of West Bengal, Public Health Engineering Directorate of Government of West Bengal etc. and direction of the Engineer-in-Charge shall govern different aspects of piling including design and workmanship.

5.2 Loading standards Pile foundations shall generally be adopted where due to high concentration of loads, spread footings may not be possible or economic and/or due to technological reasons differential settlements are restricted etc. Depending on the intensity of loading on the foundation, generally, piles with safe vertical capacity ranging from 60 – 80 t may be used. However, for foundations of minor structures, with light loads, piles of short length with safe vertical capacities of about 30 – 40 t may also be used. For piles in fresh fills, allowance shall be made for additional loads that will be passed on to them due to negative skin friction. For pile groups, the block stability vis-à-vis group settlement and group efficiency shall be checked. Lateral loads on foundations shall be generally taken care of by means of batter or raker piles. However, where the magnitude of lateral load on piles is comparatively small, the vertical piles may be designed to cater for the lateral loads. The permissible lateral load on a vertical pile shall be guided by the provisions of IS:2911 (relevant parts).

5.3 Materials and stresses Cement used shall 53 grade conform to the requirements of IS:269, IS:455, IS:8041, IS:1489 and IS:6909 (latest revisions) as the case may be PPC, OPC & PSC variety of cement may be used. Quality (OPC, PPC, PSC) will be determined by the EIC depending on use. Reinforcing steel shall conform to IS:432 (Part I) or IS:1139 or IS:1786 IS:226 (latest revisions). The stresses allowed in steel shall conform to the requirements of IS:456 (latest revision). Stresses in concrete shall not exceed those laid down in IS:456 (latest revision). Minimum grade of concrete to be used for all piling work shall be M25 (design Mix) with a minimum cement content of 450 Kg/m<sup>3</sup>. Where concrete of higher strength is required, richer concrete mix with greater cement content may be designed. Concrete used for piling shall generally have a slump of 150 mm (minimum).

However, when concrete is to be placed under water or drilling mud, higher slump of up-to 180 mm may have to be achieved.

Approved plasticizer shall be used for piling concrete at 0.2 % by weight of cement or as specified by the manufacturer.

The water used for preparing concrete shall be clean and free from acids and other impurities.

#### 5.4 Reinforcement and anchorage

The longitudinal reinforcement of the piles may be suitably curtailed beyond the point of virtual embedment after ensuring adequate anchorage. Beyond the depth of curtailment, the minimum longitudinal reinforcement

as indicated below shall be provided. Minimum clear cover to all main reinforcement in pile shaft shall not be less than 40 mm.

Minimum longitudinal reinforcement shall not be less than 0.4% of the gross cross-sectional area of the pile. Adequate lateral binders and spacers shall also be provided. Longitudinal reinforcement in excess of 8% of the gross cross-sectional area of the pile shall not be permitted for any load carrying capacity.

Piles subjected to tensile force shall be positively anchored to their caps. Anchorage shall be extended to the top of the pile cap. Vertical pedestal dowels shall be extended upto the bottom reinforcement of the pile cap.

#### 5.5 Termination levels

In general, piles shall terminate into dense sand stratum with adequate penetration. For determining the termination level of the piles within dense sand, a minimum 'N' value (as recorded from Standard Penetration Tests) of 50 shall be ensured.

Shorter piles of lower capacity may terminate on an intermediate stratum of suitable strength to obtain the design capacity.

#### 5.6 Load tests

Load test shall be conducted on working pile as per IS :2911. No. of test shall be guided by the code provision. Minimum of one (1 no.) vertical, lateral and pull-out test are to be conducted on each type of working pile in each area. The testing procedures and determination of safe loads shall follow provisions of the latest revision of IS:2911 (Part 4). If the test results are not satisfactory, the number of tests shall be increased at the discretion of the Engineer.

#### 5.7 Pile Cap

Pile Caps shall be of reinforced concrete. A minimum offset of 150 mm shall be provided beyond the outer faces of the outer most piles in the group if the pile cap is in contact with earth at the bottom, a leveling course of minimum 100 mm. thick of M 15 nominal mix concrete shall be provided. The attachment of the pile head to cap shall be adequate for the transmission of loads and forces. A portion of pile top may be stripped off from concrete and the reinforcement anchored into the cap. Manual chipping may be permitted after three days of pile casting, while pneumatic tools for chipping shall not be used before seven days after pile casting. The top of pile after stripping shall project at least 150 mm into the pile cap. A layer of surface reinforcement may be provided with a cover of 25 mm to retain the integrity of concrete below the main cap reinforcement which is to be laid 25mm. above the pile top.

Concreting of the pile cap shall be carried out in dry conditions. The bottom of the pile cap shall be laid preferably as low as possible taken account of the water level prevalent at the time of casting.

The top of concrete in a pile shall be brought above cut-off level to permit removal of all laitance and weak concrete before pile cap is laid. This will ensure good concrete at the cut-off level.

#### 5.8 IMPORTANT CONSIDERATIONS, INSPECTION/ PRECAUTIONS:

While concreting uncased pile, voids in concrete shall be avoided and sufficient head of concrete is to be maintained to prevent inflow of soil or water into the concrete. It is also necessary to take precaution during concreting to minimize the softening of the soil by excess water. Uncased cast-in-situ piles shall not be allowed where mudflow conditions exist.

The drilling mud such as bentonite suspension shall be maintained at a level sufficiently above the surrounding ground water level to ensure the stability of the strata which is being penetrated throughout the boring process until the pile has been concreted.

Where bentonite suspension is used to maintain the stability of the bore-hole, it is essential that the properties of the material be carefully controlled at stages of mixing, supply to the bore-hole and

immediately before concrete is placed. It is usual to limit:

The density of bentonite suspension to 1.05 gm/cc The marsh cone viscosity between 30 and 40

The pH value between 12 and 12

The silt content less than 1 % (one per cent)

The liquid limit of bentonite not less than 500 per cent

These aspects shall act as controlling factors for preventing contamination of bentonite slurry from clay and silt.

The bores shall be washed by bentonite flushing to ensure clean bottom at two stages viz. after completion of boring and prior to concreting after placing of reinforcement cage. Flushing of bentonite shall be done continuously with fresh bentonite slurry till the consistency of inflowing and out-flowing slurry is similar. Tremie of 150 mm. to 200 mm. diameter shall be used. For concreting the tremie should have uniform and smooth cross-section inside, and shall be withdrawn slowly ensuring adequate height of concrete outside the tremie pipe at all stages of withdrawal. Other recommendations for tremie concreting are;

The sides of the bore-hole have to be stable throughout.

The tremie shall be water-tight throughout its length and have a hopper attached at its head by a water tight connection.

The tremie pipe shall be large enough in relation to the size of aggregate. For 20 mm. aggregate the tremie pipe shall be of diameter not less than 150 mm. and for larger size aggregate tremie pipe of larger diameter is required.

The tremie pipe shall be lowered to the bottom of the bore-hole, allowing water or drilling mud to rise inside it before pouring concrete

The tremie pipe shall always to keep full of concrete and shall penetrate well into the concrete in the borehole with adequate margin of safety against accidental withdrawal if the pipe is surged to discharge the concrete.

For very long or large diameter piles use of retarding plasticizer in concrete is desirable.

For large diameter pile it may be essential to conduct non-destructive pile integrity tests to evaluate integrity of the pile.

Where possible, it may be desirable to grout the base of pile with cement slurry under suitable pressure after concrete in the pile attains the desired strength. For this purpose, conduit pipes with easily removable plugs at the bottom end should be placed in the bore along with reinforcement cage before concreting.

**5.9 Permissible Tolerances for Bore Pile:**

Variation in cross-sectional dimensions : 50mm – 10mm.

Variation from vertical or specified rake : 1 in 50

Variation in the final position of the head in plan : 50mm.

Variation of level of top of piles. :  $\pm 25$  mm.

## **6.0 Description of Items**

### **6.1 survey work**

### **6.2 Design, Supply and Construction of Collector Well: 2 No.**

1 (One) No. Collector Well having inner diameter of 6.0m and overall depth of 32.0m of which 26.0m is below river bed level and provided with minimum 16 nos. of 38m long and 400mm diameter of radial strainers in each of the 2 layers 4m apart with all ancillary, allied and related works will be constructed for withdrawal of subsurface water of river Damodar as source of water for the Piped Water Supply Scheme for Burdwan Municipality. Collector Wells should be constructed as per technical data, scope, schedule, and specification of work etc.

### **6.3 Design, Supply and Construction of M.S Access Bridge: 3.0m wide approx. 534m , 357m, 100m & 100m length**

1 (One) No. M.S Access of Bridge 3.0 wide approx. 534m , 357m, 100m & 100m length length with necessary abutments, piers, column supported on RCC/Pile foundation, walkway and railing etc. will be constructed for access to the Collector Well as well as carrying raw water rising main from Collector Well to river bank with all ancillary, allied and related works. M.S Access Bridge should be constructed as per technical data, scope, schedule, and specification of work etc.

### **6.4 Design, Supply and Construction of RCC Framed Single Storeyed Pump House Over Collector Well: 2 No. of 110.0m<sup>2</sup> Size.**

2 (One) No. RCC Framed Single Storeyed Pump House of 110.0m<sup>2</sup> Size Over Collector Well



including allancillary, allied and related works will be constructed for installation of pumping machineries for pumpingwater from the Collector Well to CWR at Head Work Site. Pump House should be constructed as per technical data, scope, schedule, and specification of work etc.

**6.5 Design, Supply and Construction of RCC Framed Single Storeyed Sub-Station Building: 1 No. of 200.0m<sup>2</sup> Size.**

1(one) No. RCC Framed Single Storeyed 200 m<sup>2</sup> size Sub-Station Building with necessary cable trench will be constructed at the Sub Station Building Site near Collector Well for power supply arrangement. Sub Station Building should be constructed as per technical data, scope, schedule, and specification of work etc.

**6.6 Design, Supply and Construction of RCC Framed Single Storeyed Office Cum godown: 1 No. of 65.0m<sup>2</sup> Size**

1(one) No. RCC Framed Single Storeyed 65 m<sup>2</sup> Size Office cum godown with water supply and sanitation arrangement will be constructed at Sub-Station Building Site. Office cum godown should be constructed as per technical data, scope, schedule, and specification of work etc.

**6.7 Design, Supply and Construction of RCC Framed Single Storeyed Guard Room: 1 No. of 14.0m<sup>2</sup> Size**

1(one) No. RCC Framed Single Storeyed 14.0 m<sup>2</sup> Size Guard Room will be constructed at the Sub-Station Building Site near Collector Well. Guard Room should be constructed as per technical data, scope, schedule, and specification of work etc.

**6.8 Design, Supply and Construction of Boundary Wall with Gate etc.: 175.0 m** Boundary wall for a total length of 175.0m will be constructed at Sub Station Building Site near Collector Well for safety of Sub Station Building Site. Height of boundary wall will be 2.0m from the FGL with tie beam at 2(two) locations with column spacing @ 2.5 m c/c. 125mm thick 1st brick work with 1:4 cement mortar will be done in panels. RCC foundation is to be provided at 1.2m below EGL. Gate and Cattle catcher is to be provided at the entrance to prevent entry of animals. Boundary wall should be constructed as per technical data, scope, schedule, and specification of work etc.

**6.9 Laying DI(K9) Raw Water Rising Main from the Collector Well to river bank :**

Raw Water Rising Main from Collector Well to river bank:

i) 500 mm dia. DI(K9) – 534m & 357m length.

900 mm dia. Balance Raw Water Rising Main will be laid from the Collector Well to the CWR at Head Work Site for pumping subsurface water of river Damodar abstracted through Collector Well. Only the portion of raw water rising main from the Collector Well to river bank on Access Bridge will be laid under this Tender.

The work should be executed with supply of all labours, materials except DI(K9) pipes which will be supplied departmentally free of cost, hire charges of machineries, equipments, tools & plants as per departmental design, drawing, specification, and direction of EIC.

**6.10 Bank Protection by Boulder Sausage Work on upstream and downstream side of the abutment of Access Bridge: 200.0m**

Bank protection by Boulder Sausage Work on upstream and downstream side of the abutment of Access Bridge, for a total length of 100.0m is required for protection of river bank from erosion for safety of the Access Bridge. This item includes supply of carried earth, spreading, ramming and compacting etc., supplying laying stone boulder with necessary G.I wire netting, under drainage system including all allied and related works as per scope of work, specification and direction of the EIC.

**6.11 Land Development at Sub Station Building Site: 100.0 Cum**

Land development of Sub Station Building Site is required to raise the level of the site for proper drainage of rain water and any water from other sources to prevent inundation of the site to maintain accessibility and workability throughout the year. Finish level should be at least 0.6m above the flood level. This item includes supply of carried earth, spreading, ramming and compacting etc.

**6.12 Design, Supply and Construction of Internal Roads, Pathways, Drains, Culverts etc. a) 4.0m width Path way over 150mm thick PCC: 50.0 meter**

b) 1.5m width Path way over 100mm thick PCC: 50.0 meter

c) Masonry surface drain having 400mm width and 450mm depth having both side wall thickness 250mm: 50.0m

4.0m wide internal roads with pavers blocks over 150 mm thk. P.C.C. and 1.5m wide walkway with pavers blocks over 100 mm thk. P.C.C. as per specification shall be constructed to provide easy access to all units throughout the year for loading, unloading, transportation of materials, operation, maintenance and supervision of system and facilities. Proper camber and grading are to be provided as per specification.

Plinth protection, perimeter drains around the buildings and overflow drains are to be constructed for drainage of rainwater, any other water from other sources, out of the Sub Station Building site to prevent any kind of inundation to maintain good working condition and to prevent any kind of damage to electro mechanical equipments.

Construction of culvert may be necessary to provide access to the Sub-Station Building Site if any drain / drainage channel exists at the entrance of the site.

### **6.13 Arboriculture and Beautification of Sub- Station Building Site: 1 Item**

The Sub- Station Building Site should be landscaped to make it blend with the surroundings and to add to the aesthetic effect, particularly when residential areas are in the near vicinity of the Sub Station Building Site. This item includes supply of manures, plants, hedges, decorative plants, seedlings etc. preparations of bed and construction of brick gabion etc.

### **6.14 Soil Investigation including all allied works at the Collector Well, Sub-Station Building site, at the Pier & abutment location for M.S Access Bridge: 1 Item**

This work should be executed in all respect with supply of all labours, materials and hire charges of machineries, equipments, tools & plants as per specification and direction of EIC for determination of safe bearing capacity of soil and other parameters required for design of foundation of different components.

### **6.15 Trail Run:**

The 6 (three) months trial run must be conducted for the works executed after successful commissioning of the scheme. The Performance Guarantee Test of 72 hrs. must be conducted in this trial run period. The contractor shall have to provide/replace of same make and specification all Civil component (if found defective during trial run) units together with the cost of all consumables materials lubricants, labour and chemicals. All defects must be set right during this period.

### **6.16 Operation & maintenance:**

Operation & maintenance of 5 (five) yr. after successful commissioning and completion of trial run is within the purview of the Bidder. The contractor shall have to provide/replace of same make and specification all Civil components (if found defective during O & M period) of the plant including the cost of all consumables lubricants, labour and chemicals. All defects must be set right during this period.

## **7 Important guidelines for civil work**

Earthwork shall be carried out in all kinds of soil, running sand, soil under water etc. and the contractor shall take enough precautions against collapse of excavations by providing 1:2 (vertical: horizontal) cut, using shoring, dewatering, etc. if necessary and shall not claim any extra payment on account of these.

The pipes and fittings in the underground walls and floors shall be built in as the work proceeds and plugged. Great care shall be taken to ensure the joint is watertight. All pipe inserts required for tanks and other underground structures shall be provided with puddle flanges. Damp-proof course shall be provided at the plinth level of all brick walls.

Finished floor level for all types of building should be considered as 600 mm above finished ground level.

Top of the plinth beam for all types of building works should be 400 mm below the existing ground level, if not specifically mentioned. Bottom of the lintel beam for all types of building works should be at 2.1 M clear height from the finished floor level, if not specifically mentioned.

Sill height for all types of building works should be 900 mm from the finished floor level, if not specifically mentioned.

Louver/ventilator should be placed below the roof beams as per direction of EIC.

Floor to floor clear height for all types of building works should be taken as 3.15M unless specified.

Chajja should be provided above all doors, windows and rolling shutters which are exposed to the sunlight. The minimum dimension away from the finished wall surface and perpendicular to it should be 500mm/1000 mm and the other dimensions along the surface of the wall should be taken considering a minimum extension of 100mm from the edge of the opening on either side. Top of the Chajja should have a required slope.

Brick masonry manhole pits, master traps, etc. shall have 20mm thick cement plaster in 1:4 cement and sand mortar to inside and outside faces. The inside faces should be finished with neat cement punning.

Brick below ground level shall have flush pointing to both faces in 1:6 cement and sand mortar. All exposed concrete surfaces shall have smooth plaster finish with cement mortar as per specification.

All walk way shall have of 1.0M with railing height of 900mm or as per drawing.

All inside faces of buildings shall have 2(Two) coats of plastic emulsion paint of approved quality and shade over two coat of primer and the external surfaces of buildings/Other Structures shall have 2(Two) coats of acrylic emulsion weather coat painting of approved colour and shade, if not specifically mentioned as per direction of EIC.

All entrance doors for Administrative Building, Staff Quarter, Operator Room, Guard Room shall be wooden flush door unless otherwise specified elsewhere.

All entrance doors for Pump House, Substation Building, Switch Room, Store and Chlorine Room shall be MS rolling shutter

All entrance doors for office room shall be aluminum panel door

All windows shall be 2/3 track sliding aluminum window

All windows shall be provided with MS grill.

Access doors to roof of the building shall be MS profile type double shutter/single door.

Parapet Wall of 750mm with aesthetic view should be provided on all the accessible roofs and accessible roof shall be provided with stair.

Proper expansion joint shall have to be considered. The boundary fencing shall be of R.C.C. post and barbed wire. The boundary wall shall RCC frame structure with two beams at two suitable locations.

All the rooms shall have sufficient number of doors and windows of appropriate material and the number and quantity to be approved by the Engineer in Charge (EIC). Openable area shall not be less than 10% and subject to maximum 25%

All internal roadway/path way shall be provided with proper beautification on both the sides with flowers, trees and gardens with garden spouts etc.

Sufficient surface drain shall have to be provided within the premises.

All reinforcement bars shall be HYSD Fe 500 grade of IS: 1786

After completion of the job at each site, all temporary structures are to be dismantled, the total site should be cleared of all debris and dismantled items etc. and the vacant area shall be converted to garden/lawns etc.

All steel structure shall have synthetic enamel paint. All finish colour to be decided by the EIC.

All roof of multi-storeyed building shall be accessible through regular stair. A regular RCC stair up to roof level shall be 1.0 m wide with 150 mm rise and 250 mm tread. Also a staircase room with doors and windows above roof level shall be provided for all buildings.

**NOTE:**

If the size and shape of any item(s) of the work have not been specified in the specification/drawing, then the shape or size of that item shall be finalized on the basis of technical ground mutually and any item or specification, if not clearly mentioned in the documents, will be finalized by the concerned EIC. The decision of the concerned EIC is final and binding and for which no extra claim will be entertained. **For water retaining structure and pipeline, 5% of the payment against that item will be retained till performing the test of satisfactory water tightness and joint test.**

**The Chairman/ Administrator**

**SECTION - H  
SPECIFICATION OF WORK (CIVIL)**

**GENERAL SPECIFICATION**

**1.0 REQUIREMENTS**

**1.1 Application of specification and item of work:**

This specification forms part of the contract and shall be read in conjunction with other documents forming the contract, viz. Notice inviting electronic Tender (NleT.), conditions and requirements of tendering, Scope of work and technical information, General conditions of contract, General and Technical Specification, drawings, Bill of quantities and schedule of probable items of works.

The offered rates must cover the cost of all materials (except DI pipes which will be supplied departmentally free of cost), all taxes & duties in vogue, labour, tools, machinery, plant, explosives, scaffolding, staging, shoring, props, bamboos, ropes, templates, pegs, and all appliances and operations whatever necessary for efficient execution and completion of the work. All works are to be executed in accordance with descriptions in the schedule of item of works along with the specifications, terms, conditions provided elsewhere in the tender documents.

Item of works and their details which are not covered by this specification, shall be carried out as per those of P.H.E/ P.W. Department, Govt. of West Bengal and relevant I.S. recommendation.

Manner of works not included above, should be carried out as per relevant provisions of Manual on Water Supply and Treatment by CMEDEO, relevant I.S. specifications and code of practice and as per manufacturer's specification (where ever necessary).

The overall outline of works to be done by the contractor and the details have been mentioned in the item of works in the schedule and in the specification, drawing and elsewhere in the tender documents. Each scheduled item has to be carried out and completed by the contractor at the accepted rate covering the full extent outlined in the schedule and specification and notwithstanding any omission in mentioning of supply and execution of such component of works except in special case specifically mentioned. Items indicated in the schedule are exhaustive. Yet if there by any short fall felt by the tenderer he may include the same while quoting his rate so as to make the item complete in all respect for successful completion of the work.

The contractor's works shall be guided by the total requirement briefly outlined and shall include additional works other than those component of works mentioned in the item to complete the work. The tenderer or the contractor has to completely execute the full requirements ensuring performance guarantee of each component of the works, equipment and machinery so that all the individual components are brought up to the optimum condition for sustained and satisfactory operation individually and collectively.

**1.2 Site Condition:**

The contractor is to visit the site and ascertain local conditions, traffic restrictions, and obstructions in the area before submission of tender paper to satisfy himself.

**1.3 Soil characteristic:**

The contractor shall obtain all soil characteristics through soil test to find out the exact nature of the soil. However, for Tendering purpose, the **Soil Bearing Capacity (SBC)** may be adopted as **7.50 MT / Sqm** and Subsoil water level shall be considered at finished Ground Level. Afterward of

contract if contractor's soil test results show SBC value is less than **7.50 MT / Sqm**, the design is to be carried out with that soil test report, for which no extra cost shall be paid by MEDDte to the contractor. However, if the soil tests results show SBC value greater than **7.50MT / Sqm**, the design may be based on same.

**1.4 Setting out and leveling:**

The contractor is to set out and level all the works in accordance with the approved drawings and will be responsible for the accuracy of the same. They have to provide all instruments, setting out equipments and proper qualified staff required for the setting works. If any error will be found during checking by the department, re-setting out will have to be carried out by the contractor without any extra payment. If any works found faulty due to erroneous setting out works, the contractor shall have to rectify the same without any extra cost.

**1.5 Safety Code:**

The contractor shall take adequate precaution to provide complete safety for prevention of accidents on the site.

**1.6 Keeping works free from water:**

The contractor shall provide and maintain at his own cost, electrically or other power-driven pumps and other plant and equipment to keep the site and foundation pits and trenches free from water and continue to do so till the site is handed over to the complete satisfaction of E.I.C.

**1.7 Clear Site:**

The site during the execution of works should have sober and tidy appearance with everything necessary for the work neatly and systematically arranged.

The contractor at his own cost shall clear the site of all trees, roots and obstructions. Where excavation is required, that should be done strictly up-to the required level. Any surplus earth should be spread over the low lands or used in earth filling works for development of site. After the completion of the work, the entire site shall be cleared satisfactorily with (a) all pits, diggings and trenches properly filled up (b) all surfaces adequately dressed (c) all surplus materials, sheds, tents and all other ancillaries removed from the site at his own cost.

**1.8 Bench Marks and Ground Water Gauges:**

The contractor shall establish and protect surveyor's benchmarks and base line marks from damage or movement during work at his cost.

**1.9 Inspection:**

The contractor shall inspect the site of work and ascertain site conditions and the nature of soil to be excavated.

**1.10 Contractor's Staff:**

The contractor must provide at all times efficient staff of trustworthy, skillful and experienced assistants capable of carrying out the work in accordance with the drawings and specifications and to correct levels in accordance with the provisions made in the relevant clause of the PQ Bid document.

**1.11 Measurement of Work:**

The CONTRACTOR or his authorized site engineer shall be available at site at all reasonable times to take joint measurement of work done for the purpose of payment and shall also provide without any extra charges, the necessary measuring instruments and men.

**1.12 List of I.S. Code of Practices & others Publications:**

A list of few important Indian Standards (latest edition) is given which does not cover all the relevant sides of practices. Wherever reference towards the Indian standards mentioned below or otherwise appears in the specification, it shall be taken as reference to the latest version of the standard.

SL.NO.	IS NO.	DESCRIPTION
1.	<b>IS-1200 (Part-I to 28)</b>	Measurement of Building Works, method materials & details of construction.
2.	SP :7 - 1983	National Building code of India. (first revision)
3.	IS-4082: 1996	Stacking of storage of constructional materials at site recommendation.
4.	IS-3764	Safety Code for Excavation Work.
5.	IS-3696	Safety Code for Scaffolds and Ladders.
6	IS-15875	Loading standards.
7.	IS-1893 & 4326	Earth Quake deign.
8.	IS-1080 & 2950	Foundations.
9.	<b>IS-1199: 1959</b>	Sampling & Analyzing of concrete.
10.	IS-8142: 1976	Tests for setting time of concrete.

11.	IS-516 : 1959	Tests for strength of concrete.
12.	IS-9013 : 1978	Tests for compressive strength.
13.	IS-4031	Tests for cement.
14.	IS-2911 : 1985 (Part –4)	Load test on piles.
15.	IS-3495	Methods of Testing Burnt Clay Bldg. Bricks.
16.	IS-3114 : 1965 (art-6)	Method of hydraulic test of water supply pipe line.
17.	IS-3597 : 1985	Method of testing of concrete pipes.
18.	IS-12969 : 1990	Method of test for quality characteristics of valves.
19.	IS-11606	Methods for sampling of C.I. Pipes & Fittings.
20.	IS-822 : 1970	Procedure for inspection of welds.
21.	IS-73-07 (Part – I)	Approved tests for welding procedures (fusion welding of steel)
22.	IS-7310 (Part – I)	Approved tests for welders working to approved welding procedure (Part I : fusion welding of steel).
23.	IS-2595 : 1978	Code of practice for radiographic testing.
24.	IS-4853 : 1968	Recommended practice for radiographic examination of fusion welded circumferential joints Steel Pipes.
25.	IS-1182 : 1967	Recommended practice for radiographic examination of fusion welded butt joints.
26.	IS-269: 1989	Ordinary, Rapid hardening & low heat Portland Cement – 33 Grade
27.	IS-8112 : 1989	Ordinary, Rapid hardening & low heat Portland Cement – 43 Grade
28.	IS-12269 : 1987	Ordinary, Rapid hardening & low heat Portland Cement – 53 Grade
29.	IS:455-1989	Portland slag cement.
30.	IS:6452-1989	High Alumina cement for structural use
31.	IS:8041-1990	Rapid hardening Portland cement.
32.	IS-1489(Part-I & 2) : 1991	Portland Pozzolona Cement.
33.	IS-1726	Admixture of concrete.

34.	IS-2645	Internal cement water proofing compounds.
35.	Sand IS-1542	Sand for plaster
36.	IS:2116-1980	Sand for masonry mortars
37.	Aggregates IS:383-1970	Aggregates coarse and fine from natural sources for concrete.
38.	Aggregates IS:515-1959	Aggregates for use in Mass Concrete Natural and manufactured.
39.	Bricks IS: 1077-1992	Common Burnt clay-building bricks.
40.	Soil IS:1489-1970	Classification & Identification of Soil for General Engineering purpose.
41.	Steel : Iron Work IS-1786 : 1985	High yield strength deformed bar (Grade Fe 415).
42.	IS-2062 : 1992	Structural steel.
43.	IS-814 : 1991	Electrodes for manual metal arc welding.
44.	IS-2062 (Grade-A)	Low Carbon structural steel.
45.	IS-808 : 1989	Rolled Steel Beams, Channels and angles.
46.	IS-1038 : 1983	Steel doors, windows & Ventilators.
47.	IS-1052 : 1983	Specification for Collapsible Gate.
48.	IS-7452 : 1990	Hot rolled steel section for doors, windows and ventilators.
49.	IS-1361	Steel Windows for Industrial Buildings.
50.	IS-412	Expanded Metal Steel Sheets for General Purpose.
51.	IS-1948	Aluminum Doors, Windows and Ventilators.
52.	IS-1949	Aluminum Windows Industrial Buildings.
53.	IS-4021 : 1995	Timber door window and ventilator frames.
54.	IS-1003 : 1991	Timber paneled and glazed door shutters.
55.	IS-2202 : 1991	Wooden flush door shutters. (Solid core type).

56.	IS-287	Recommendations for Maximum Permissible Moisture Content of Timber used for Different Purpose.
57.	IS-6198	Ledges, Braced and Battened Timber Door Shutters.
58.	IS-204	Tower bolts.

59.	IS-205	Non-ferrous metal butt hinges.
60.	IS-208	Door Handles.
61.	IS-281	Mild Steel Sliding Door Bolts for use with Padlocks.
62.	IS-2681	Non-ferrous Metal Sliding Door Bolts for use with Padlocks.
63.	IS-451	Technical Supply Conditions for Wood Screws.
64.	IS-1823	Floor Door Stopper.
65.	IS-2209	Mortice Lock (vertical type).
66.	IS-6607	Rebated Mortice Locks (vertical type).
67.	IS-3564	Door Closers (hydraulically regulated).
68.	IS-3847	Door Handles for Mortice Locks (vertical type).
69.	IS-363	Hasps and Staples.
70.	IS-419	Putty for use on Window Frames.
71.	IS-1237 : 1980	Flooring Tiles of Cement concrete.
72.	IS-777 : 1988	Glazed E.W. wall tiles.
73.	IS-4457 : 1982	Ceramic unglazed vitreous acid resisting tiles.
74.	IS-458 : 1988	Precast concrete pipe.
75.	IS-1230 : 1979	CI Rain Water Pipes & Fittings.
76.	IS:651	Salt-glazed-stoneware sanitary appliances
77.	IS:771	Glazed earthenware sanitary appliances
78.	IS:2556	Vitreous sanitary appliances (vitreous China)
79.	IS:774	Flushing cisterns for water closets and urinals, valueless symphonic type
80.	IS:775	Brackets and supports for wash basins and sinks
81.	IS:781	Sand-cast brass screw down bin taps and stop taps for water services
82.	IS:1795	Pillar taps
83.	IS:2326	Automatic flushing cisterns for urinals
84.	IS:2548	Plastic water-closet seats and covers
85.	IS:2963	Copper alloy waste fittings for wash basins and sinks
86.	IS: 4004	Plug cocks for water supply purpose

87.	IS:3311	Waste plug and its accessories for sinks and wash basins
88.	IS:4346	Washers for water taps for cold water services
89.	IS:778	Copper alloy gate, globe and check valve for water works purpose
90.	IS-780 : 1984	Sluice valves for water works purposes. (Small dia-50 mm to 400 mm size).
91.	IS-2906 : 1984	- do - (Higher dia-350 mm to 1200 mm size).
92.	IS-13095 : 1991	Butterfly valves for general purposes.
93.	IS-12992 : 1993	Spring loaded safety relief valves.
94.	IS-5312 : 1984	Swing check type reflux valves.
95.	IS-3042 : 1965	Single faced sluice gate (200 mm – 1200 mm).
96.	IS-5312 (Part-I) : 1984	Swing check type reflux (non-return) (single door) valves.
97.	IS-5312 (Part-II) : 1986	-do- (Multi door pattern)
98.	IS-12820 : 1989	Dimensional requirements for rubber gasket for mechanical joints & push on joints.
99.	IS-1726	Cast iron manhole covers and frames intended for use in drainage works.
100.	IS-1322 : 1993	Bitumen felt for water proofing and damp proofing.
101.	SP-23	Hand book of concrete Mix Design.
102.	Concrete IS-456 : 2000	Code of Practice for plain & reinforced concrete (1st revision).
103.	IS-4926 : 1973	Specification for ready mixed concrete. (first revision)

104.	IS:3370 - Part-I/1965	Code of Practice for concrete structures for the storage of Liquids-General requirements.
105.	IS-3370 - Part-II/1965	– do - - do – reinforced concrete structures.
106.	IS-1786 : 1985	Tor steel reinforcement.
107.	IS-2751 : 1966	Welding of reinforcement.
108.	IS-2502 : 1963	Bending & fixing of bars for concrete reinforcement.
109.	SP-34	Hand book of concrete Reinforcement and detailing.
110.	IS-9077 : 1979	Corrosion protection of steel reinforcement in R.C.C. structure.
111.	Is-2911 : 1979 (Part-I Section –2)	Design & construction of bored cast in situ concrete piles.

112.	IS-800 : 1984	Use of structural steel in general building construction.
113.	IS-816 : 1991	Use of metal in welding for general construction in mild steel.
114.	IS-823	Procedures for manual arc welding of mild steel.
115.	IS-4353	Submerged Arc Welding of Mild Steel and Low Alloy Steels.
116.	IS-6494 : 1988	Water proofing of under-ground water reservoir and swimming pools.
117.	IS-3067 : 1988	General design details and preparatory work for damp proofing and water proofing of building.
118.	IS-2750	Steel Scaffoldings.
119.	IS-4014	Code of Practice for Steel Tubular Scaffolding
120.	IRC-SP-63	Guideline for use of interlocking concrete block pavement.
121.	IS-2114 : 1984	Laying in situ terrazzo floor finish.
122.	IS-1443 : 1972	Cement concrete flooring tiles, laying and finishing off.
123.	IS-2571 : 1970	Laying in situ cement concrete flooring.
124.	IS-1081	Code of Practice for Fixing and Glazing of Metal Doors, Windows and Ventilators.
125.	IS-6248 : 1979	Specification for metal Rolling Shutter and Rolling Grill.
126.	IS-1868 : 1983	Code of practice for Fabrication of Aluminum Door & Window
127.	IS-1661 : 1972	Cement & Cement lime plaster finishes.
128.	IS-6278	Code of Practice for white washing and colour washing.
129.	IS-102	Ready mixed paint, brushing, red lead, non-setting, priming.
130.	IS-1477	Code of Practice for painting of ferrous metals in buildings.
131.	IS-2074	Ready mixed paint, red oxide zinc chrome priming.
132.	IS-2339	Aluminum paint for general purposes.
133.	IS-12288 : 1998	Specification for use and laying of Ductile Iron Pipes.
134.	IS-3114 : 1994	Laying of C.I. Pipes.
135.	IS-783 : 1985	Laying of concrete pipe.
136.	IS:7634	Laying and P.V.C. Pipes
137.	IS-5822 : 1994	Laying of Electrically Welded Steel Pipes for water supply.
138.	IS-782 :1978	Caulking Lead.
139.	IS-3950 : 1979	Surface boxes for sluice valves.
140.	IS-10221 : 1982	Coating & wrapping of underground mild steel pipe lines.
141.	SP-35(S&P)	Hand book on Water Supply & Sanitary works.
142.	IS-2685 : 1971	Specification for selection, installation and maintenance of Sluice Valves.
143.	IS-2800	Code of practice for construction & testing of Tube-well.
144.	IS:1742	Code of practice for building drainage
175.	IS:2065	Code of practice for water supply in buildings
146.	IS 4353	Code of practice for welding
147.	IS7307, & IS 7310	Code of practice for Qualification standard for welding procedures, welding and welding operations
148.	IS 5878	Code of practice for Welding defects
149.	IS 2595	Code of practice for Radiographic testing



150.	IS 4853	Code of practice for Radiographic Examination of Fusion Welded circumferential joints
151.	IS 1182	Code of practice for Radiographic Examination of Fusion Welded Butt joints
152.	IS 2598	Safety code for Industrial Radiographic practice.

**N.B.** :For rest of the I.S. Codes the Contractor should consult classified list of Indian standard,CivilEngineering Dept (CED) of latest version.

## 2.0 APPROVAL OF MATERIALS

Sample of materials in sufficiently large quantity with descriptive data thereof shall be furnished by the contractor to the Engineer-in-charge well before the collection of such materials and equipments so as to permit inspection, testing and approval. The sample shall be properly marked to show the name of the materials, name of manufacturer, place of origin and item for which it is to be used. After approval, the sample shall be available for inspection at all time.

All brought out/manufactured items such as valves, gate valves, penstock, HOT crane etc. to be supplied by the contractor shall conform to the requisite I.S. specification properly tested and duly certified. Those are to be approved by the Engineer-in-charge before use. **Third party inspection of such materials has to be arranged by the agency and to be approved by the tender inviting authority.**

139.	IS-3950 : 1979	Surface boxes for sluice valves.
140.	IS-10221 : 1982	Coating & wrapping of underground mild steel pipe lines.
141.	SP-35(S&P)	Hand book on Water Supply & Sanitary works.
142.	IS-2685 : 1971	Specification for selection, installation and maintenance of Sluice Valves.
143.	IS-2800	Code of practice for construction & testing of Tube-well.
144.	IS:1742	Code of practice for building drainage
175.	IS:2065	Code of practice for water supply in buildings
146.	IS 4353	Code of practice for welding
147.	IS7307, & IS 7310	Code of practice for Qualification standard for welding procedures, welding and welding operations
148.	IS 5878	Code of practice for Welding defects
149.	IS 2595	Code of practice for Radiographic testing
150.	IS 4853	Code of practice for Radiographic Examination of Fusion Welded circumferential joints
151.	IS 1182	Code of practice for Radiographic Examination of Fusion Welded Butt joints
152.	IS 2598	Safety code for Industrial Radiographic practice.

## 2.5 MATERIALS

### 3.1 Stone Chips:

These should be obtainable by the contractor from Pakur/Panchami, well graded conforming to the standard specifications of P.W.D. and approved by the Engineer-in-charge.

### 3.2 Sand :

Sand for construction purpose shall have to be collected either from Simlagar or river bed of Damodar / Damodar / Kangsabati or Ajoy and should be coarse, cleaned, screened and washed & of quality conforming to the standard specification of P.W.D/ this Directorate and also to be approved by the Engineer-in-charge.

### 3.3 Brick :

Bricks shall be of first class quality, well burnt in kiln, sound hard , true to shape and of the standard dimensions, and to be got approved by the Engineer-in-charge before use.

### 3.4 Plasticiser :

Super-Plasticiser of SIKA / CICO make conforming to IS: 2645-1975 & IS: 9103-1974 must be used.

### 3.5 Bolts & Nuts:

Make : GKW / TATA or Equivalent

Bolts and nuts conforming to the requirements of turned grade bolts of symbol 4D, 5D and 53 specifications - IS: 1363 (latest edition) – Technical supply conditions for threaded fastener.

The screw thread shall conform to coarse series – medium class referred in IS: 1367 (latest edition).

**4.0 MAT CONCRETE OR FOUNDATION CONCRETE**

100 mm thick concrete of proportion 1:2:4 with 20 mm downgraded stone chips (Chandil /Panchami/ Pakur variety) shall be provided below all the foundations and structures over a layer of Brick Flat soling as approved by Engineer-in-charge.

**5.0 EXCAVATIONS AND FILLING**

**5.1** The earthwork in excavation up-to required depth from E.G.L requires proper adequate /protection of surrounding soil/structure against collapse .This protection may be in form of MSsheet piling / salballah piling / construction of diaphragm wall or any other suitable methodapproved by EIC .Ground water table may be lowered below working level by well point orany other method suitable for easement in construction. The design of excavation work sideprotection measures should match with requirement at site and space available. The whol methodology for excavation work, protection measures, ground water lowering should beadequately design using relevant soil parameter and approved by EIC before execution. Anycollapse /failure of the surrounding should be rectified / reconstructed if required immediatlyin consultation with EIC without any extra cost whatsoever.

**5.2** Excavations necessary for the works may require digging and penetration through any soilorstrata, removal of stems and roots of tress, breaking and removal of old structures, salballah,dewatering from all sources e.g. rain, seepage, leakage, subsoil water etc. protecting the trenchand well pit and adjoining structures and service lines, by timbering, shoring, propping, sheetpiling etc. Excavation shall be done only up-to the required level and all extra depth ofexcavation, if made, has to be filled in with materials and manners approved by the Engineering-charge.

**5.3** All excavated materials must be carefully deposited in spoil bank allowing the access toworkers and plant machinery. The toe of the spoil bank shall be set at sufficient distance and should not be less than 3 to 4 times the depth of excavation. If so ordered by the Engineer-incharge, the excavated materials have to be carried away and placed within a lead of 75 meter.Such quantity of extra materials as may be required shall be brought back to back-fill the trenchwith proper consolidation in layers of 150 mm thickness, properly rammed. Flooding of trenchpit during back filling may be resorted to if so directed by the Engineer-in-charge.

5.4	Contractor must make good at his own cost, all damages or settlements sustained by any structure founded on the trench or adjacent to the trench. All excavated materials will remain the property of the Government and the contractor shallbe responsible for their custody till the completion of the works or taking over by theDepartment.Fill below the pipe trenches, inside building below the floor etc. shall have to be done withsand free from any foreign material. In case of over-excavation below the stipulated depth the space between the foundation bottom
-----	--

and over-excavated area shall be filled up with silver sand consolidated by watering and vibrating. Where such consolidation is not achievable, the depth of excavation shall be filled with plain cement concrete of mix 1:4:8. The cost in both the cases shall have to be borne by the Contractor.

5.8	All materials obtained from any excavation required to be carried out under this contract willbe utilized by the contractor for spreading over the land uniformly at his cost.
-----	--

**6.0 PROTECTION WORKS: -**

**6.1 Damp proofing work:**

Unless otherwise specified, damp proof course shall be 25 mm thick cement concrete with stone chips (Prop. 1:2:4) with 3% “CICO” or specified percentage of “Rola / Sica” or similar approved water proofing compound by weight of cement. The proportioning, mixing, laying etc. shall be done in conformity with relevant I.S. specification. The damp proof course shall be used for all brick walls of the buildings. No damp-proof course shall be laid under doors.

**6.2 Anti-termite Treatment: -**

Anti-termite treatment as per relevant IS recommendation shall be carried out for all the building structure like pumping station , Substation, Staff Quarters, Office Building etc. prior to construction and post construction.

**7.0 BRICK MASONRY**

Brick work shall be laid in English bond with mortar in proportion 4:1 unless otherwise

specified. Brick work shall always be carried out regularly in plumb and true to plan and lines, in level along the entire length. No brickwork shall be carried out more than one scaffolding height of 1.5 meter in the stage. Bricks are to be well soaked with water before use and brickwork shall be kept clean and joints raked out for subsequent pointing or plastering. Brick work in foundation and superstructure not in contact with water shall be provided with 20 mm and 15 mm thick plaster to rough and fair faces respectively with cement sand mortar in 1:6 proportions. Brick work in contact with water shall be in cement sand mortar in 1:4 proportion 20 mm thick plaster with water proofing compound as per specification including 1.5 mm thick cement punning in the water contact face. 15 mm thick plastering in 1:6 cement sand mortar in the outer face shall be provided. "Cement Brick" will mean brick work in cement sand mortar in proportion as mentioned above.

### **8.0 R.C.C. WORKS**

The R.C.C. works are generally to be conducted by R.M.C/Design Mix concrete and shall be as per specification of I.S. codes, and stated elsewhere in the specification and schedule of Tender Document. In a few cases as mentioned in relevant Schedule of Work R.C.C. works with nominal mix M-20 Concrete shall be used as per specification of relevant I.S. Code. For major R.C.C. works (Where concrete is specified by strength) the mix proportion should not be leaner than 1:1.5:3 so as to give ultimate crushing strength not less than 20 N/mm<sup>2</sup> at 28 days cured under field condition. The mix for the concrete is to be so adopted and the slump is to be so allowed as to give specified strength and proper workability at the existing site conditions.

Contractor shall remain fully responsible for producing concrete of specified strength in the actual job and therefore cast at his own cost test specimens of 15 cm. cubes as already specified during work and cure the same in similar way as for laid concrete for being tested for strength.

Each set of test specimen shall be taken to cover the quantity of concrete laid on the job during the period from the time of taking the previous set of specimens and the quantity will be estimated by the Engineer-in-charge from records maintained by him.

The interior surface of the mould and base plate shall be lightly oiled before the concrete is placed in the mould. When the job concrete is compacted by ordinary methods, the test specimen shall be molded by placing the fresh concrete in the mould in three layers, each approximately one-third of the volume of the mould. In placing each scoopful of concrete, the scoop shall be moved around the top edge of the mould as the concrete there slides from it in order to ensure a uniform distribution of concrete within the mould. Each layer shall be rodded, 25 times with a 16-mm rod, 60 cm in length bullet pointed at the lower end. The strokes shall be distributed in a uniform manner over the cross-section of the mould and shall penetrate into the underlying layer. The bottom layer shall be rodded, throughout its depth. After the top layer has been rodded, the surface of the concrete shall be struck off with a trowel and covered with a glass plate at least 6.5 mm. thick or a machined metal plate. The whole process of molding shall be carried out in such a manner as to preclude the alteration of the water-cement ratio of the concrete, by loss of water either by leakage from the bottom or overflow from the top of the mould. When the job concrete is placed by vibration and consistency of the concrete is such that the test-specimens cannot be properly molded by hand rodding as described above, the specimens shall be vibrated to give a compaction corresponding to that of the job concrete. The fresh concrete shall be placed in the mould in two layers each approximately half the volume of the mould. In placing each scoop full of concrete the scoop shall be moved around the top edge of the mould as the concrete there slides from it in order to ensure a symmetrical distribution of concrete within the mould. Either internal or external vibrator may be used. The vibration of

each layer shall not be continued longer than is necessary to secure the required density.

Internal vibrators shall be of appropriate size and shall penetrate only the layer to be compacted. In compacting the first layer, the vibrators shall not be allowed to rest on the bottom of the mould. In placing the concrete for the top layer, the mould shall be filled to the extent that there will be no mortar loss during vibration. After vibrating the second layer, enough concrete shall be added to bring the level above the top of the mould. The surface of the concrete shall then be struck off with a trowel and covered with a glass or steel plate as

specified above. The whole process of moulding shall be carried out in such a manner as to preclude the alternation of water-cement ratio of the concrete by loss of water either by leakage from the bottom or overflow from the top of the mould.

After curing, the specimen properly wrapped shall be handed over to the Engineer-in-charge or his representative who will arrange to have them tested at 28 days from the date of casting.

If there be any delay for any reason whatsoever the result of the test shall nevertheless be valid and will be applicable as per rules in case for all test specimens whatsoever. The contractor shall be

responsible for proper packing of the specimens at his own cost, for safe and convenient transport of the same from the site to the testing laboratory. The cost of testing the test moulds and other charges including cost of carriage of the test moulds from the work site to the particular laboratory (both ways) and other incidental charges in this connection will have to be borne by the contractor.

In case of concrete showing, on the result of the cube tests, strength less than that as specified above in the "Acceptance Criteria" but has a strength greater than that mentioned in the said "Acceptance Criteria" concrete may, at the discretion of the Engineer-in-charge, be accepted as being structurally adequate without further testing.

If the concrete is deemed not to comply the "Acceptance Criteria", the structural adequacy of the parts affected may be investigated as per provision of Clause 17.4 and/or clause 17.6 of I.S. 456-2000 as the case may be before rejection on the application of the Contractor with the undertaking to bear the cost of such tests.

If the strength of the concrete is such that it satisfies provisions made in sub clause 17.4.3 and /or sub-clause 17.6.3. of IS: 456-2000, concrete in that member represented by such tests shall be considered acceptable but the Engineer-in-Charge shall have the full power to fix the rate of deduction @ 500/- per cubic meter.

In case the test results do not satisfy the relevant requirement of the preceding paragraph, the Volume of concrete so deficient shall be deemed to be unacceptable and shall be removed from the structure and replaced by fresh concrete of specified strength and the contractor shall in that case have to carry out the instruction of the Engineer-in-Charge irrespective of the amount of loss, inconvenience and difficulties involved.

The contractor shall remain liable to act / to carry out instruction under the provision of this clause notwithstanding issuing by the Engineer-in-Charge of any certificates or the passing of any bills or accounts.

#### **8.1 Mixing and Laying:**

All concrete shall be mixed in Mechanical mixer and all concrete work in foundation; superstructure etc. shall be properly vibrated with the help of mechanical vibrator as per direction of Engineer-in-charge. Concrete Mixer Machine, Vibrator and all other tools and plants as required shall have to be arranged by the contractor at his own cost.

#### **8.2 Mortars and Concrete:**

Contractors are particularly warned against the use of inferior materials (to that specified or approved) at site or use of incorrect proportion of different materials in the makeup of concrete or mortar. Detection of any such practice will lead to rejection of all such works and imposition of penalty. Engineer-in-charge has the right to reject any mortar or concrete, which does not conform to the specification. Cube tests for concrete are to be done as per I.S. code at the cost of the contractor. The water cement ratio is to be determined by proper slump test or as per provision of relevant I.S. In case of slump test the slump cones 30 cm. high 20 cm. dia. at bottom and 10 cm. at top are to be kept at site at the cost of the contractor.

<b>8.3</b>	<b>Finishing:</b> If the surface of the concrete is found uneven or spongy in the appearance, the contractor will
------------	--

have to rectify or reconstruct at his own cost.

All R.C.C. work in wall, column, beam, roof, foundation etc., not forming part of water retaining structure shall be done in M25 grade concrete as per I.S.: 456 with cement content not less than 500 Kg/cu.m. of concrete. Plasticizer @ 0.2% by weight of cement shall be used. The water cement ratio should not exceed 0.45.

All R.C.C. work forming part of water retaining structure shall be done in M30 grade of concrete as per IS: 456; with cement content not less than 425 Kg/cu.m. of concrete. Plasticizer @ 0.2% by weight of cement shall be used. The water cement ratio should not exceed 0.45.

The concrete shall be cured as per I.S.: 456

#### **8.4 Cement and Aggregate:**

**8.4.1 Cement:** The cement shall be OPC, Slag or Pozolana conform to relevant I.S. Code, grade not less than 43. Selection of type and grade of cement shall be approved by the EIC. Cement tests shall have to be carried out at contractor's expenses as and when directed. The contractor shall make arrangement with necessary equipment to carry out crushing strength of 150 cm. Cube concrete block for 7 day's & 28 day's of proper curing. Testing procedure, sample size shall be in accordance with relevant I.S.

#### **8.4.2 Aggregate:**

The fine and course aggregates shall conform to relevant I.S. Stone chips and sand for construction work shall have to be supplied as per clause 2.5 of this specification.

Concrete shall be sampled, analyzed tested in accordance with I.S. as furnished in the list.

**8.5 Joints in Concrete Structure:**

Type of joints, spacing of joints, use of all jointing materials and other features pertaining to the provision of movement joints in liquid-retaining structures shall be as per relevant I.S. Codes.

**8.6 Reinforcement of R.C.C. Works:**

The M.S. work should include cutting to sizes, bending, hooking and fabricating including the supply of B.W.G. wire, and all other works according to specification, drawing or otherwise. The M.S. reinforcement rods if to be procured by the tenderer shall be HYSD bars (Fe-500) as per IS 1786-2008. The contractor shall intimate the department regarding the quantity of steel to be procured by him in the works and the same may be supplied at the agreed rate specified in General terms and conditions.

**8.7 Clear Cover:**

The clear cover to reinforcement shall be maintained as per IS-456-2000 based on the actual exposure conditions which shall not be less than the followings unless otherwise specified in drawing.

- a) Water retaining face 30 mm
- b) Other than water retaining face 25 mm for beam and 15 mm for roof and floor
- c) Column, Pedestal Foundation and Pile 50 mm

**8.8 Lap Length:**

The Lap length of reinforcement shall be provided as given below; unless otherwise specified in drawing.

Compression members like column, struts @ 40 times the dia of bar.

Tension members like beam, slab, wall etc @ 50 times the dia of bar.

Following Development length/Anchorage length shall be provided :

Concrete Grade	M 15	M 20	M 25	M 30
Development Length	68 D	51 D	46 D	36 D
Anchorage	As per I.S. – 456-2000			

The reinforcement work will include cutting to sizes, bending, hooking binding with 14 to 18 S.W.G. soft pliable wires etc. as per P.W.D. schedule. The work shall also be inclusive of stirrups, distributors, binders etc.

**8.9 Bar Bending Schedule:**

The contractor shall prepare his “Bar Bending Schedule” for the entire construction work in phases before starting the work and shall submit it to the EIC for his approval.

Cutting of M.S. rods in an unplanned way will not be allowed and for that if any material is found to be wasted or have to be used in excess due to the fault of the contractor, no payment shall be made on this score and the cost of such excess material shall be realized from the contractor’s bill at penal rate as specified elsewhere of this tender document.

The item of M.S work should include the cost of reinforcement, cutting to sizes, bending and fabricating including the supply of R.W.G wire, bolts and nuts etc. and all other work according to specifications, drawing or otherwise. Cut pieces of steel materials less than 1.0 mtr cannot be used as a main bar.

**8.10 Form Work**

The form work shall conform to relevant I.S. Code of practice. Shuttering in form work shall be either made of steel or ply board. Surface of shuttering in contact with concrete shall be made smooth & at joints rendered smooth. In every case the joints of the shuttering are to be such as to prevent the loss of liquid from the concrete. All shuttering form work must be adequately stayed and braced to the satisfaction of the Engineer-in-charge for properly supporting the concrete during the period of hardening. All form works shall be removed without shock or vibration. Before the form work is stripped, concrete surface shall be exposed when necessary in order to ascertain that the concrete has set and hardened sufficiently.

**8.11 Staging & scaffolding:**

Whenever necessary, staging and scaffolding must be provided. All shuttering and framing must adequately be stayed and braced to the satisfaction of the Engineer-in-charge for properly supporting the concrete during the period of hardening. It shall be so constructed that it may withstand the jerk and shock of vibration of concrete.

Scaffolding must be strong and rigidly stiffened with necessary cross bracings and proper deck at every stage where casting work is in progress to prevent any injuries to persons and to facilitate inspection, supervision and taking measurement at any time.

The hire and labour charges for staging, scaffolding, platform etc. as provided in the schedule of works is for the entire construction work including shell wall of reservoir etc till completion of work and removing the same as per direction and instruction of EIC.

8.1 2	<b>Curing and Finishing:</b> The joint shall be cleaned off the gray cement slurry with wire/coir brush or trowel to a depth
----------	---

of 2 mm to 3 mm and all dust and loose mortar removed. Joints shall then be flush pointed with white cement. The floor shall then be kept wet for 7 days. After curing the surface shall be washed and finished clean. The finished floor and wall shall not sound hollow when tapped with a wooden mallet.

**8.13 Verticality of structure:**

The vertical members should be perfectly vertical and no deviation in x – axis and /or y- axis is admissible. The Contractor should take adequate precautionary measures to ensure that the structure is constructed true to plumb. Similarly all horizontal members of the structures should be truly horizontal.

<b>9.0</b>	<b>TESTING OF CONCRETE :</b>
<b>9.1</b>	<b>Frequency of sampling:</b>

**9.1.1 Sampling Procedure** – A random sampling procedure shall be adopted to ensure that each concrete batch shall have a reasonable chance of being tested i.e. the sampling should be spread over the entire period of concreting and cover all mixing units.

**9.1.2 Frequency** – The minimum frequency of sampling of concrete of each grade shall be in accordance with the following;

Quantity of Concrete in the Work, m3      Number of Samples

- 1-5      1
- 6-15    2
- 16-30   3
- 31-50   4

51 and above	4 plus one additional sample for each additional 50 m3 or part thereof
--------------	--

**9.1.3 Test Specimen**- Three test specimens shall be made from each sample for testing at 28 days. Additional cubes may be required for various purposes such as to determine the strength of concrete at 7 days or at the time of striking the form work or to determine the duration of curing, or to check the testing error. Additional cubes may also be required for testing cubes cured by accelerated methods as described in IS: 9013-1978. The specimen shall be tested as described in IS: 516-1959.

**9.2 Test Strength of Sample:**

The test strength of the sample shall be the average of the strength of three specimens.

The individual variation should not be more than ±15 percent of the average.

Concrete shall be handled from the place of mixing to the place of final deposit as rapidly as practicable by methods which will prevent the segregation or loss of the ingredients. It shall be deposited as nearly as practicable in the final position to avoid re-handling of flowing.

Unless specially permitted by the Engineer-In-Charge, concrete shall not be dropped freely from a height of more than 2 meters.

Before placing the concrete, the moulds shall be cleaned of shavings, pieces of wood or other rubbish. When placing the concrete, the finer materials must be carefully worked against the moulds so that the faces of concrete shall be left perfectly smooth and free from honeycombing upon withdrawal of the moulds. Any defect in this respect must be dealt with by the contractor as directed by the Engineer-in-charge without any extra charges therefore.

Depositing concrete under water shall not be allowed without specific permission from the Engineer-in-charge. The method of concreting to be adopted in such cases shall have to be previously approved by him.

During placing and also immediately after deposition, the concrete shall be thoroughly compacted by ramming, spearing etc. until it has been made to penetrate and fill all the spaces between and around the steel rods, around embedded fixtures, and into the corners of formwork in such a manner as to ensure a solid mass entirely free from voids. If so directed by the Engineer-in-charge, in addition to usual ramming, spearing etc. sufficient number and suitable type of vibrators may have to be used on important jobs to enable working with a comparatively low water-cement ratio and ensure the maximum possible degree of compaction and homogeneity. It is

imperative that the work should be done quickly as well as efficiently and adequate number of hands must therefore be employed to ensure this.

Concrete shall be placed and compacted in its final position before setting has commenced and shall not subsequently be disturbed.

Concreting shall be carried out continuously up to construction joints the position and arrangement of which shall be predetermined by the Engineer-in-charge or his representative. Any rest, pauses, such as for meal, shall also be subject to his approval. All concreting work should be so programmed as not to necessitate work at night. If for any reasons this becomes imperative, the contractor shall obtain previous permission of the Engineer-in-charge or his representative and make proper lighting arrangements to his satisfaction.

### **9.3 Protections and Curing**

The contractor shall adequately protect freshly laid concrete, about 1 to 2 hours after its laying from too rapid drying due to sunshine, drying winds etc. and also from rains or surface water and shocks about 24 hours after laying of concrete, the surface shall be cured by flooding with water of minimum 25 mm. depth or by covering with wet absorbent materials viz. layer of sacks, canvas, Hessian or similar materials and shall be kept constant wet for a period of not less than 10 (ten) days from the date of placing the concrete. The curing shall be done for a minimum period of 10 days. Over the foundation concrete the masonry work may be started after 48 hours of its laying, but the curing of cement concrete shall be continued along with the masonry work for a minimum period of 10 days.

In case of cement concrete used as sub-grade for flooring, the flooring may be commenced within 48 hours of the laying of sub-grade. In case it is not possible to do so due to exigencies of work, the sub-grade shall be roughened with a steel wire brush without disturbing the concrete, wetted and neat cement slurry at the rate of 1.75 Kg of cement per square meter applied to the base before laying floor and full rate of APS/mosaic flooring will be paid with the specific orders of the Engineer-in-charge. The curing is to be continued along with the top layer of flooring for a minimum period of 10 days.

### **10.0 CONSTRUCTION JOINTS**

All joints in slabs and other horizontal members are to be formed by inserting vertical boards against which the concrete deposited can be properly rammed. The Engineer-in-Charge or his representative will indicate the positions where such joints may be made.

In the case of horizontal joints any excess mortar or laitance shall be removed from the surface after the concrete is deposited and before it has set.

When the work has to be commenced on a surface which has hardened, such surface shall be well roughened and all laitance removed; the surface shall then be swept clean, thoroughly wetted and covered with a thin layer of mortar composed of equal volumes of cement and such works shall be deemed to be covered by the rates for concrete.

### **11.0 PLASTERING, PAINTING & SURFACE TREATMENT**

#### **11.1 Cement:**

It should be fresh Portland/Slag cement (not less than grade 43) as specified in relevant I.S. Different Types of cement shall not be mixed together. In case more than one type of cement is used, a record shall be kept showing the location and the types of cement used.

#### **11.2 Sand:**

It shall be hard, durable, clean and free from adherent coatings and organic matter and shall not contain the amount of clay, silt and fine dust more than 5% by mass. It shall not also contain any harmful impurities such as iron pyrites, alkalis, salts, coal or other organic impurities, mica, shale or similar laminated materials, soft fragments, sea shale in such a form or in such quantities as to affect adversely the hardening, strength or durability of the mortar. The grading of sand for use in Plaster shall be conforming to I.S: 1542-1977.

In case the sand is damp at the time of preparation of mortar, its quantity shall be increased suitably to allow for bulkage in conforming to I.S. 2386 (Part-III) 1963.

#### **11.3 Preparation of Mortar:**

The materials shall be at first mixed dry thoroughly in suitable proportion as stated in the schedule till uniform colour reaches and then shall be mixed wet adding water slowly and gradually for at least four times to give a uniform paste. The mix as prepared shall be used within 30 minutes. Wherever plasticizer is required to use, the quantity of water shall be reduced in such a proportion that required consistency is achieved.

#### **11.4 Preparation of Surface:**

The surface of wall shall be brushed, cleaned, washed, watered and wetted with water before plastering. All the projections extending more than 13 mm from the general face of the

masonry should be knocked off so as to maintain thinner plaster layer. All the joints in masonry should be raked for a depth of about 20 mm. In case of plastering on concrete surfaces, the face should be roughened by chipping of about 5 mm. Oily, greasy and efflorescence spots should be removed either by brushing, scrapping or both.

**11.5 Laying:**

In order to maintain uniform thickness of the plaster, the screeds are formed on the prepared wall surface before actual plastering is started. Patches of plaster 15 cm x 15 cm are first of all applied at an interval of about 2 m both horizontally and vertically over the surface. The two dots lying in vertical strips of mortar are formed between dots. Then the plastering shall be started from the top and worked towards the bottom. The whole surface shall be made flush between the screeds with wooden straight edges and rubbed thoroughly with wooden floats. Rounding of corners if desired by the Engineer-in-charge shall be carried out in one operation.

**11.6 Curing:**

The plastered surface shall be kept wet by sprinkling water after 12 hours for at least 7 days and shall be protected from rain or sun.

**11.7 Thickness:**

Unless otherwise specified or desired by E.I.C. the thickness of plaster shall be as follows:-

- a) Plumbed Surface of Brick work (1:6) - 15 mm
- b) Rough Surface of brickwork (1:6) - 20 mm
- c) Vertical concrete surface (1:4) - 10 mm
- d) Ceiling of Roof, Chajja etc. (1:4) - 10 mm
- e) Water Retaining Face (1:4) - 20 mm

Cement Pointing to Exposed Brick Facing Where shown on the approved drawings or specified in schedule of work, exposed brick faces shall be cement ruled pointed. The mortar shall be raked out of the joints to a depth of 6 mm. The dust shall be brushed out of the joints.

**12.0 ROOF TREATMENT**

Clean the roof surface by wire brush & water jet properly. Apply 1st coat of cement slurry admixed with diluted Sika Raintile-1/Sika Latex Powder (S:W:C=1:4:6) or equivalent upto a height of 150mm on vertical surface of the parapet wall. Apply 2nd coat of the above slurry after drying of 1st coat. While the 2nd coat of cement slurry is still tacky, a screed concrete (1:1.5:3) shall be laid with 6 mm down aggregate admixed with Sika Plastocrete super or equivalent (conforming to IS : 264) with a minimum average thickness of 50mm laid with proper slope. The junction with parapet wall will be properly finished with slope using cement sand mortar (1:4) admixed with diluted Sika Raintile-1/ Sika Latex Powder (1:6) or equivalent with ratio not less than 0.5 (Diluted admixture : cement). Proper curing shall be done after completion of the treatment.

**12.5 DOORS & WINDOWS :**

**13.1.1 Wooden Doors:**

All shutters of wooden doors shall be made of North Bengal Variety teak wood as per relevant I.S. Code and must be approved by the Engineer-in-charge. Frames shall be made of Sal Wood.

**13.1.2 Other Materials:**

Materials required for the purpose of erection of door frame and shutter complete in all respect are to be supplied by the contractor and they must conform to schedule of Indian Standard or P.W.D. specification & also to be approved by the Engineer-in-charge. Other materials to be supplied by the contractor also must conform to relevant I.S. & P.W.D. Schedule of specification.

<b>13.</b>	<b>Glazed window:-</b>
<b>2</b>	The glazing will be of 3mm thick Ordinary glass (4.4 kg/sq.m) as per I.S.

**13.2.1 Glazing Fixing :**

Glazing of timber doors, windows and ventilators shall conform to IS:1003. All glass panels shall be cut smooth (either ground or polished) so as to have a clearance of 2.5mm between the edge of the glass and the surrounding. The wooden frame particularly the rebate shall be well oiled to prevent oil from putty being sucked by wood. The frame shall be cleaned thoroughly and sufficient putty applied to the rebate so that when the glass is pressed into back putty not less than 1.5mm thick remains. Surplus compound squeezing out at the back shall be stripped at an angle so that water is shed away. The glass shall be sprigged for rebates not more than 45mm apart around its perimeter and neatly front puttied to form a triangular fillet stopping 1.5mm short of the sight line.

<b>13.</b>	<b>Steel Window:</b>
<b>3</b>	The frames and sashes of steel window, ventilators, sky light both fixed and moveable



type are
----------

To be made from hot rolled steel sections conforming to relevant I.S. The tolerance in thickness of section shall be + 0.2 mm. The steel windows/ventilators and composite unit shall be got fabricated in the work-shop approved by E.I.C. The windows/ventilators shall strictly be according to the specified sizes and design. The actual size of windows/ventilators shall not vary by more than + 1.5 mm. from those given in the drawing.

**13.3.1** The corner of frame shall be welded to form a solid fused welded joint and the processes of welding shall be flash butt welding, the section for glazing shall be turned and riveted in the frames. The welds should be made all along the place of meeting the members and tack weldings should not be permitted. Weld should be properly grounded and complete cross section of the corner shall be thoroughly checked up, so that no cavities are visible.

**13.3.2** For fixing steel hinges in "side hung windows" slots shall be cut in the fixed frame and hinges inserted inside and welded to the frame at the back. The hinges shall be of projecting type, non-projecting type hinges may be allowed if approved by E.I.C. The hinge pin and washer shall be of galvanized steel or aluminum alloy of suitable thickness. The handle of side hung shutter shall be of pressed brass, cast brass, aluminum or steel protecting against rusting and shall be mounted on a steel plate. The handle plate shall be welded, screwed, and/or riveted to the opening frame in such a manner that it should be fixed before the shutter is glazed.

**13.3.3** The handle shall have a two point nose which shall engage with a brass or an aluminum alloy striking plate on the fixed frame in a slightly open position as well as close position. The boss of handle shall incorporate as friction device to prevent the handle from dropping under its own weight. In case of no friction type hinges are provided, the windows shall be fitted with peg-stays which shall be either black oxidized steel, pressed or cast brass, or as specified, 400mm long with steel peg and locking brackets. The peg stay shall have three holes to open the side hung casement in three different angles. Side hung shutter fitted with friction hinges shall not be provided with a peg stay.

13. 4	<b>Aluminum Window:</b> All the windows are to be made of Aluminum unless otherwise specified or approved by the EIC.
----------	--

The frames and sashes of Aluminum window, ventilators, and skylight both fixed and moveable type is to be made from Aluminum sections conforming to relevant I.S. The tolerance in thickness of section shall be + 0.2 mm. The Aluminum windows/ventilators and composite unit shall be got fabricated in the workshop approved by E.I.C. The windows/ventilators shall strictly be according to the specified sizes and design. The actual size of windows/ventilators shall not vary by more than + 1.5 mm. from those given in the drawing.

**13.4.1** The corner of frame shall be welded to form a solid fused welded joint and the processes of welding shall be flash butt welding, the section for glazing shall be turned and riveted in the frames. The welds should be made all along the place of meeting the members and tack weldings should not be permitted. Weld should be properly grounded and complete cross section of the corner shall be thoroughly checked up, so that no cavities are visible.

**13.4.2** For fixing steel hinges in "side hung windows" slots shall be cut in the fixed frame and hinges inserted inside and welded to the frame at the back. The hinges shall be of projecting type, non-projecting type hinges may be allowed if approved by E.I.C. The hinge pin and washer shall be of galvanized steel or aluminum alloy of suitable thickness. The handle of side hung shutter shall be of pressed brass, cast brass, aluminum or steel protecting against rusting and shall be mounted on a steel plate. The handle plate shall be welded, screwed, and/or riveted to the opening frame in such a manner that it should be fixed before the shutter is glazed.

**13.4.3** The handle shall have a two-point nose, which shall engage with a brass or an aluminum alloy striking plate on the fixed frame in a slightly open position as well as close position. The boss of handle shall incorporate as friction device to prevent the handle from dropping under its own weight. In case of no friction type hinges are provided, the windows shall be fitted with peg-stays which shall be either black oxidized steel, pressed or cast brass, or as specified, 400mm long with steel peg and locking brackets. The peg stay shall have three holes to open the side hung casement in three different angles. Side hung shutter fitted with friction hinges shall not be provided with a peg stay.

### **13.5 P.V.C. DOOR:**

#### **13.5.1 P.V.C. Frame & Shutter:**

P.V.C. Door frame shall be made from extruded P.V.C. multi chamber hollow section having dimensions 60 mm X 50 mm / 60 mm X 53 mm and suitably reinforced, horizontal section will be joined with vertical section by steel screws after inserting two number steel brackets as reinforcement making suitable space for placing hinges, one stud tube 40 mm X 20 mm X 18 gauge

will be inserted on one full vertical side of the frame (hinge side) as reinforcement.

**13.5.2** The quality and shade of P.V.C. door shutter must be approved by the Engineer-in-charge. The P.V.C. door shutter shall be made of rigid P.V.C. multi cavity hollow chamber of suitable size and section as mentioned in the schedule of rates with 2.5 mm wall thickness, the section will have two nos. built in bends. Horizontal and Vertical section shall be fixed by each other by self tapping screws and 2 nos. of M.S. tubular galvanized bracket of length 200 mm X 80 mm and other 100 mm X 100 mm both 18 gauge in each corner of the shutter frame for placing hinges, polymer based multi cavity hollow section of 2.5 mm wall thickness will be fitted in the middle with aluminum cleat and steel screws as lock rail, the section frame will then be fitted in by Polymer based panel of size as mentioned in the schedule and 2 nos. of 6 mm dia bright rod will be inserted horizontally with both side check and nut system and stretches where fixing of hinges/hasp bolt/tower bolt/door ring are required to be strong enough to with-stand wear and tear.

<b>14.</b>	<b>GRILLS:</b>
<b>0</b>	All windows, ventilators and railings where specified, shall be provided with suitable

M.S. grills of approved design. The clear openings between two bars shall not exceed 100mm. The entire grill work including fitting, fixing shall have to be done as per specification laid down in P.W.D. Schedule.

The grill shall have to be provided with 2 coats of paints of approved make and shade over one coat of priming. The grill may also be used in some doors. The M.S. flats to be used for grill shall not be less than 20 mm X 4 mm is size. The weight of the grill shall be within 18kg/sq.m. to 20 kg/sq.m.

<b>15.</b>	<b>ROLLING SHUTTER:</b>
<b>0</b>	The M.S. rolling shutters shall be as per I.S.: 6248-1979 and shall be obtained from as approved

by the Engineer-in-charge. The rolling shutter shall be of 18G X 75 mm cold rolled steel laths of convex corrugation complete with one piece construction. These shall be fitted with pressed wise guides and pressed bottom rail, brackets, door suspension shafts, top rolling spring (of strong English continental spring steel wire) with four lever lock as also separate locking arrangement for padlocks, pulling hooks, handles and top cover. The roller shutter shall be fixed in position with all accessories and the design and the workmanship shall be to the entire satisfaction of the Engineer-in-charge. These shall be finished with 2 coats of approved paint over a coat of priming. Shutters upto 10 sq.m. shall be of push and pull type & shutters with areas of over 10 sq.m. shall be provided with reduction gear operated by mechanical device with chain and pulley.

**16.0 HAND RAILING ON WALKWAY/PLATFORM :**

All walkways, platforms, R.C.C. stair etc. shall have to be provided with railing on the open side or sides throughout. The height of the railings shall be 1.2 meter. The post of the railing shall be made MS tubes of approved design. It should be made rigidly fixed with the Walkway / platform/floor and shall have two coats of approved painting over one coat of priming.

**16.1 Heavy Type Railing with MS Posts:**

**16.1.1** This type of railing shall be of 1200 mm height, comprising of MS post, as per approved drawing placed, @ 500 mm c/c.

**16.1.2** The railing shall be provided with two rows of 32 mm dia. MS tubes (TATA medium quality) run parallel through the holes of the MS posts. The end of the MS railing shall be secured with the post firmly by suitable welding.

**16.2 Heavy Type Railing with C.I. Posts:**

**16.2.1** This type of railing shall be of 900 mm height, comprising of 1000 mm high ornamental C.I. post of weight not less than 28 kg/post with suitable base, as per drawing placed, @ 1500 mm c/c.

**16.2.2** The railing shall be provided with two rows of 32 mm dia. MS tubes (TATA medium quality) run parallel through the holes of the C.I. posts. The end of the MS railing shall be secured with the post firmly by suitable welding.

**16.2.3** The railing shall be finished with applying two coats of high gloss synthetic enamel paint of approved make and said over a coat of red lead primer.

**16.3 Light Type Railing with GI Posts:**

**16.3.1** This type of railing shall also be of 900 mm height and made of G.I. post using 32 mm dia. G.I. pipe (TATA medium quality). The post shall be placed @ maximum 500 mm c/c or as specified in the drawing.

**16.3.2** The railing shall also be consisting of two rows of G.I. pipe (TATA medium quality) and integrated/secured with the G.I. post by suitable welding of minimum 5 mm thick at a every junction and intersection.

**16.3.3** The G.I. post shall be embedded in the floor up-to a minimum depth of 80 mm all welding surface shall be grounded to have smooth finish. Finally the total assembly shall be

finished with two coats of synthetic enamel painting to all the exposed surfaces of G.I. pipes.

**16.3.4** The railing shall be finished with applying two coats of high gloss synthetic enamel paint of approved make and said over a coat of red lead primer.

17. 0 17. 1	<p><b>FLOOR FINISH ETC.</b></p> <p><b>Artificial Stone Floorings:</b></p> <p>The artificial stone flooring shall be laid in shape &amp; size as directed. The casting of the panels will be so programmed as to prevent bonding of the freshly laid panel with adjacent panels.</p>
----------------------	---

Unless otherwise specified, the underlay shall be with graded stone chips 12mm down, the thickness of topping shall be of 10mm thick & colouring pigment as may be required shall only be added with the topping. The topping & the underlay shall not be laid in one operation. After laying the underlay the surface is allowed to dry. The topping shall be laid only after the underlay is sufficiently dry & initially set & after thoroughly brushing with hand wire brush & cleaning & after application of slurry. The topping will be finished with the clean piece of dry linen. The invert level shall be carefully observed & maintained.

The corner between floor & wall shall be rounded off for which no extra payment shall be made. All cement concrete surfaces should be chipped off properly before taking up the flooring work as per the direction of E.I.C.

17. 2	<p><b>Terrazzo Flooring:</b></p> <p>The mosaic shall be of 25 mm thickness and shall have to be done over 100 mm thick base</p>
----------	---

concrete (1:2:4) for floor. The mosaic shall be 20 mm thick for places other than floor.

**17.2.1** The aggregates used in terrazzo mosaic topping shall be marble aggregates of approved grade, size and required colour, Marble powder used in terrazzo topping shall pass through I.S. Sieve 30.

**17.2.2** Aggregates for terrazzo under layer as well as base concrete shall conform to requirements of ordinary cement concrete (1:2:4), size of coarse aggregate not exceeding 15 mm grade and size of chips used. Cement used for floor finish work shall be ordinary cement or white cement of approved quality. Pigments incorporated in terrazzo shall be of approved make and brand and of permanent colour. The dividing strips may be of glass, thickness of strip shall not be less than 1.5 mm and width not less than 20 mm.

**17.2.3** The mix for terrazzo topping consists of cement with or without pigments, marble powder, marble aggregates and water. The proportion of marble powder shall be 3 parts of cement and one part of powder by weight.

**17.2.4** The proportion of cement shall be inclusive of any pigments added to cement.

**17.2.5** Terrazzo topping shall be laid while the under layer is still plastic, but is hardened sufficiently normally between 18 & 24 hrs. after the laying of the under layer, terrazzo topping may be laid. A cement slurry, preferably of the same colour as the topping shall be brushed on the surface immediately before laying is commenced. The terrazzo topping shall be compacted thoroughly by tamping or rolling and troweled smooth. Excessive troweling or rolling in early stages shall be avoided. The compaction shall ensure that air is cleared from the mix.

**17.2.6** The surface shall be left dry for air curing for a duration of 12 to 18 hrs. and then be cured by allowing water to stand in pools over it for a period of not less than 4 days.

**17.2.7** Grinding and polishing may be done either by hand or by machine. The first and second grinding shall be done with Carborundum Stone of Grit size 60 & 80 respectively. After each grinding the surface shall be washed clean and grouted with neat cement grout of same colour (without marble powder) of cream like consistency and then shall be allowed to dry for 24 hours and wet cured for 4 days. The third grinding shall be done with carborundum stone of grit size 120 to 150 and the surface shall then be washed clean and allowed to dry for 11 hours and wet cured for 4 days. The fourth grinding shall be done with carborundum stone of grit size 320 to 500 and the surface shall then be washed clean and the surface shall then be washed clean and rubbed hard with felt and slightly moistened oxalic acid powder (5 grams of oxalic acid powder per sq.m. of floor area shall be adequate) and finally the surface shall be washed clean with dilute oxalic acid solution and dried.

**17.3 Metallic Hardener topping floor :**

**17.3.1 Metallic Hardening Compound :**

The compound shall be of approved quality consisting of uniformly graded iron particles, free from non-ferrous metal particles, oil, grease sand, soluble alkaline compounds. Where so directed by the Company Representative it shall be tested as per Appendix-III.

**17.3.2 Base Concrete:**

Flooring shall be laid on base concrete where so provided. The base concrete shall be

provided with slopes required for the flooring in verandah, bath & kitchen shall have slope ranging from 1:48 to 60 depending upon location or as directed.

**17.3.3** If the cement concrete flooring is to be laid directly on the RCC slab, the top surface of RCC slab shall be cleaned and a coat of cement slurry at 2 kg cement spread over an area of one sqm to get a good bond between the base and concrete floor.

**17.3.4 Under Layer :**

Cement concrete flooring of specified thickness and mix shall be laid as under layer. The top surface shall be roughened with brushes while the concrete is still green and the forms shall be kept projecting, up 12mm over the concrete surface, to receive the metallic hardening compound topping.

**17.3.5 Topping :**

This shall consist of metallic hardener topping 12 mm thick with the proportion by volume 1:2 cement and 6 mm size stone aggregate along with metallic hardening compound of approved quality consisting of uniformly graded iron particle free from nonferrous metal particles, oil, grease, sand, soluble alkaline compound. The metallic hardening compound shall be mixed in the ratio of 1:4 (1 – metallic concrete hardener: 4 cement) by weight. Metallic hardener shall be dry mixed thoroughly with cement on a clean dry pucca platform.

This dry mixture shall be mixed with stone aggregate 6 mm nominal size or as otherwise specified in the ratio of 1:2 (1- cement : 2 – Stone – Aggregate) by volume and well turned over. Just enough clean water shall then be added to this dry mix as required for floor concrete.

**17.3.6** The mixture so obtained shall be laid in 12 mm thickness on 32 mm thick cement concrete floor except otherwise specified, using cement concrete (1:1.5:3) as under layer within 2 (two) to 4 (four) hours of its laying. During construction of this under layer the top surface of it, shall be roughened with brushes while the concrete is still green and the forms shall be kept projecting up 12 mm over the concrete surface, to receive the metallic hardener compound topping.

**18.0 CERAMIC TILES FLOORING / WALLING :**

**18.1.1** The tile shall be of approved make and generally conform to I.S. 13755, IS 777, IS 388. The tile shall be of earthenware covered by a glaze thoroughly matured and fitted to the body. The tile shall be flat, sound, true to shape and free from blisters, crazing, chips, welts, crawling or other imperfections detracting from their appearance when viewed from a distance of 1 m.

**18.1.2** The tile shall be square or rectangular of nominal size such as 100 mm X 100 mm, 100 mm X 200 mm or as directed by the E.I.C. The thickness of the tiles shall be 5 mm or 6 mm as specified. The average length, breadth shall not vary more than + 0.5 mm. Tolerance in thickness shall be + 0.4 mm.

**18.1.3** The top surface of the tiles shall be glazed and glaze shall be either glossy or matt as specified. The underside of the tiles shall not have glaze on more than 5% of the area in order that the tile may adhere properly to the base. The edges of the tile shall be preferably glazed.

**18.1.4** Besides, the tile shall be resistant to chemical and average rate of absorption of water shall not exceed 20% when tested in accordance to I.S. 777, IS 388.

**18.2 Preparation of surface of Wall & Laying on it:**

**18.2.1** The joints shall be raked out to a depth of at least 15 mm in masonry walls. In case of concrete walls, the surface shall be hacked and roughened with wire brushes. The surface shall be cleaned thoroughly, washed with water and kept wet before walling/skirting is commenced.

**18.2.2** 12 mm thick plaster of cement mortar 1:3 (1 cement : 3 coarse sand) mix or as specified shall be applied and allowed to harden. The plaster shall be roughened with wire brushes or by scratching diagonal at closed intervals.

**18.2.3** The marble chips, 3 mm to 4 mm size, shall be fixed on the back side of the tiles adopting the same procedure as mentioned earlier to help increase the bonding. The tiles fixed with marble chips should be soaked in water thoroughly for few hours, washed clean and coat of cement slurry shall be applied liberally at the back of tiles and set in the bedding mortar. The tiles shall be tamped and corrected to proper plane and lines. The tiles shall be set in the required pattern and jointed. The joint shall be as fine as possible. Top of skirting/wall shall be truly horizontal and joints truly vertical except where otherwise indicated. Skirting shall rest on the top of the flooring. Where full size tiles cannot be fixed there shall be cut (sawn) to the required size and their edges rubbed smooth.

**18.3 Curing and Finishing:**

**18.3.1** The joint shall be cleaned off the grey cement slurry with wire/coir brush or trowel to a depth of 2 mm to 3 mm and all dust and loose mortar removed. Joints shall then be flush pointed with white cement. The floor shall then be kept wet for 7 days. After curing the surface shall be washed and finished clean. The finished floor and wall shall not sound hollow when tapped with a wooden mallet.

**19.0 WHITE WASHING:**

**19.1** White washing shall be done with 5 parts of stone lime and one part of shell lime with necessary gum (about 2 kg. Per cum. Of lime) using indigo as necessary and to be mixed as per standard practice and direction of the Engineer-in-Charge. The lime shall be brought to the site un-slaked and shall be slaked at site with an excess of water and allowed to remain under water for 2 days. To the mixture, fresh water may be added to bring the consistency to that of a thin cream. When thoroughly mixed, the wash is to be strained through coarse cloth. The surface of the wall is to be brushed thoroughly clean before the white washing is applied. Each coat of the white wash has to be laid on with brush. One coat of white wash means one continuous strike of brush with the proper wash. Each coat must be perfectly uniform when finished and free from brush mark etc.  
**19.2** 3 coats of white wash will mean a minimum of 3 coats to produce an opaque white-surface to entire satisfaction of the Engineer-in-Charge. If the surface is blotchy or otherwise unsatisfactory, more number of coats shall be applied till the desired effect is produced to the satisfaction of the Engineer-in-Charge without any extra cost.

**20.0 COLOUR WASHING :**

**20.1** Colour washing shall be carried out in the same manner as that of white washing, colour ingredient being added to the prepared white wash so as to produce the approved colour & shade. The colouring ingredient shall be obtained by the contractor from an approved source.  
**20.2** Coats of colour wash will mean a minimum of 2 coats to produce the desired effect to the entire satisfaction of the Engineer-in-Charge. If the surface is blotchy or otherwise unsatisfactory, more coats shall be applied till the satisfaction of the E.I.C. without any extra cost.

**21.0 SNOW CEM OR SIMILAR DECORATIVE CEMENT BASED COLOUR FINISH:**

**21.1** Where specified, external surface shall be finished with 2 coats of "Snow Cem" or similar decorative cement based colour finish of approved colour, shade & manufacture. The surface is to be previously cleaned down to removed loose dust or dirt by use of stiff wire brush. All inequalities to be rubbed down and defects rectified. The surface to be wetted well with water and the surface water is to be allowed to run off. The "Snow Cem" or equivalent to be mixed will be strictly as per manufacturer's specification. The mixed "Snow Cem" or equivalent to be applied to the surface with a brush of a good quality Snow Cem or equivalent application shall be wetted at the end of the day with a fine water spray.

**22.0 WASHABLE DISTEMPER:-**

All inside plastered surfaces of buildings & other structures shall be painted with washable Distemper as per manufacturer's specifications unless otherwise specified or directed by the EIC to approved shade and colour.

22. 1	<b>OUTSIDE PAINTING BY WEATHER COAT:</b> All outside surfaces of buildings & other structures shall be painted with damp proof weather
----------	---

coat as per manufacturer's specifications unless otherwise specified or directed by the EIC to approved shade and colour.  
Where specified, external surface shall be finished with 2 coats of "Weather Coat" or similar decorative colour finish of approved colour, shade & manufacture. The surface is to be previously cleaned down to remove loose dust or dirt by use of stiff wire brush. All inequalities to be rubbed down and defects rectified. The surface to be wetted well with water and the surface water is to be allowed to run off. The "Weather Coat" or equivalent to be mixed will be strictly as per manufacturer's specification.

22. 5 23. 1	<b>PAINTING TO WOOD &amp; STEEL WORK:</b> Ready mixed synthetic enamel paint of E.I.C. Asian Paints / Berger / Deluxe/ Nerolac/Jenson & Nicholson make and of approved colour and shade shall only be used. The primer shall be
----------------------	---

Of Murarka's red lead primer for steel surface and white or gray wood primer of aforesaid make for wood surface.

**23.2** The steel surface to be painted shall be properly cleaned & de-rusted, all loose scales removed and smoothed with emery papers. Then a coat of anticorrosive priming shall be evenly applied. After this has dried up, two successive coats of best quality ready mixed paint of approved quality and shade shall be given to the entire satisfaction of the Engineer-in-Charge. Brushes of approved size and make shall only be used for application of paint and use of cloth is definitely prohibited.

**23.3** All wood surfaces for painting shall be properly sand papered and cleaned.

When necessary, good quality putty shall be used to hide all holes, cracks, open joints etc. The rate for

painting includes surface finishing work.

**23.4** The rate includes cost of all operation mentioned above and is for the complete work.

**24.  
0  
24.  
1**

**INTERNAL SANITARY AND PLUMBING WORK**

**General:-**

**24.1.1** All water supply, drainage and sanitary work shall be executed by a licensed or authorized plumbing supervisor or a licensed or authorized plumber and shall be in accordance with the requirements of relevant bye-laws of Municipal or other Authorities in whose jurisdiction the work is being carried out.

For item such as earthwork, excavation, concrete, brickwork, stonework, pointing etc. relevant specifications for these shall apply, unless specified otherwise.

Unless otherwise specified, all exposed work such as cisterns, brackets etc. shall be painted with one coat of red oxide paint and two coats of oil paint of approved color and make.

The diameter of pipes and fittings wherever mentioned shall mean the internal diameter, unless otherwise specified.

**24.1.2** The job shall include the cost of making the necessary chases, holes etc. in walls, floors and other places and also making good on completion of the works. Any damage caused to floors, walls etc. during the sanitary and plumbing works shall be made good by the Contractor at his own cost to the satisfaction of the Engineer-in-Charge.

**24.1.3** The plumbing system will be 'Two Pipe System' with partial ventilating arrangement i.e., all traps of soil appliances are completely ventilated through a separate ventilating system.

**24.1.4** Bib taps, pillar taps, and shower roses shall be of heavy chromium plated brass of approved make and shall conform to relevant IS code.

**24.1.5** All vent pipes and soil pipes shall be cast iron, 5mm thick conforming to IS:3989 and shall be jointed with tarred gasket and lead.

**24.1.6** All pipes, fittings and fixings shall be of best quality and the works shall be completed as per direction and to the entire satisfaction of the Engineer-in-Charge.

**24.1.7** The toilets shall be connected through master traps in pits to Plot Sewer line complete.

**24.2 Materials :**

**24.2.1 Materials, fittings and appliances for sanitary and plumbing work:**

The materials, fitting and appliances used in the work shall be as specified hereunder and of I.S.I. or as per approved drawing. The Contractor shall submit to the Engineer-in-Charge samples of all materials, fittings and appliances for approval well in advance of starting the work. All materials, fitting and appliances used in the work shall conform to the approved samples.

**24.2.2 Galvanized pipes and fitting:**

Galvanized steel pipes (medium quality and diameter 15mm & 25mm), fittings and accessories for water services shall be of tested quality and shall conform to IS:1239.

**24.2.3 Cast iron pipes and accessories:**

Cast iron pipes (diameter 100mm) with socket and spigot ends shall conform to IS:1230 and IS:1729.

**24.2.4 Manhole covers:**

Manhole covers shall conform to IS:1726 & BS12592 RCPC or PFRC.

(a) 20MT cover:- 685X100-110 mm, frame:- 900X900X180mm, weight:- 240kg.(approx)

(a) 5MT cover:- 550X65 mm, frame:- 650X650X135mm, weight:- 90kg.(approx)

(b) 5MT cover:- 425X55mm, frame:- 540X540X100mm, weight:- 60kg.(approx)

**24.2.5 Plumbing & Sanitary appliance and non-ferrous fittings:**

All sanitary appliances and non-ferrous fittings shall be of tested quality and shall conform to the relevant Indian Standards.

**24.3 Joint:-**

**24.3.1 Cast iron pipes:**

The type of jointing for CI pipes shall be either socket or spigot with molten lead or lead wool or flanged type with nuts, bolts and gasket as indicated on the drawings. If the joints used are spigot and socket type, the spigot shall be carefully centered in the socket by one or more laps of clean white hemp spunyarn with about 25mm overlap. Sufficient yarn only shall be forced into the socket to leave a correct depth of lead for caulking. The pipe shall then be examined again for line and level and the proper depth of each joint shall be tested before running the molten lead. For pouring of molten lead a ring of hemp rope shall be wrapped around the pipe at the end of the socket and the joint shall be covered with stiff damp clay. The rope shall then be removed carefully leaving a V-shaped large hole at the top of the joint to pour the molten lead. Lead shall be poured in one operation only. After a section of convenient length of pipe has been laid, lead shall be caulked sufficiently with a hard

hammer and the joint shall be made neat and clean. The packing ring or washer for the flanged joints shall be rubber for the full diameter of the flange with proper pipe hole and bolt holes cut out suitably. The packing shall be smeared with graphite paste or a mixture of red lead and white lead and shall be introduced between the flanges of both the pipes and nuts tightened in opposite pairs keeping the longitudinal axes and adjoining pipe lines in exactly the same straight line. Lead washers shall be provided along with bolts to prevent any leakage through bolt holes.

**24.4 Laying of Pipes:-**

**24.4.1 Cast iron pipes:**

The laying of cast iron pipelines shall commence only after the bottom of the trench at various points have been leveled and aligned in accordance with the drawings. The sides of the trenches shall be as vertical as possible, and the width at the bottom shall be 450mm wider than the diameter of the pipe. Where joints are made, the trench shall be widened suitably to provide room for caulking joints. Shoring and timbering shall not be used without prior approval of the Engineer-in-charge. For pipes buried in the ground, the Contractor shall take care to maintain always the minimum cushion of earth over the pipes as indicated in the drawings. All pipes, water mains, cables etc. met within the course of excavation shall be carefully protected and supported. All pipes and fittings shall be sounded with a light hammer to detect any cracks before laying. The excavated materials shall be placed on one side of the trench and the pipes stacked on the other side. The inside of socket and the outside of spigot shall be thoroughly cleaned of all foreign matter before laying. The pipes shall be laid with their socket ends facing the direction of the flow. The pipes shall be lowered in the trenches by a method as approved by the Engineer-in-Charge. The pipes shall then be jointed by caulking as specified in clause 16:1. After each section of the pipeline has been laid it shall be tested for water-tightness before back filling the trench. On successful completion of testing, the trench shall be back filled with the excavated earth in layers of 200mm and shall be watered and rammed. Any subsidence occurring in the line of trenches after backfilling shall be repaired by the Contractor at his own cost. Where the pipelines cross roads, the sides of the trenches shall be suitably shored.

**24.4.2 UPVC Rainwater Pipes:**

UPVC rainwater pipes shall conform to IS:13502-1992 and shall be installed as per approved position. Rainwater pipes fixed to the external walls and shall be blocked out at least 25mm from the plastered surface by means of cast iron bobbins. The rain-water pipes at the roof level shall be fitted with UPVC Roof outlet bend or a UPVC bend with a masonry bell mouth of suitable size fitted with a cast iron grating. The bottom of the down pipe shall be fitted with ashoe fixed 150mm above ground/apron level of the building as shown on the drawings. The sockets and spigots of pipes and fittings shall be jointed using cement mortar (1:2). UPVC rainwater pipes embedded in concrete or masonry and shall be securely fixed to wall with wooden plugs and nails. Joints of the sockets and spigots of pipes and fittings shall be with cement mortar (1:2).

24. 5	<p><b>Gully trap pit :</b></p> <p>Gully trap pits shall be constructed as per I.S.I. &amp; drawings. The Construction and finishing of</p>
----------	--

the pit shall be as described for inspection pit. The cast iron grating shall be set flush with the finished ground / apron level.

**24.6 Testing of Cast Iron, Soil and Waste Pipeline:**

On completion of laying, the cast iron, soil, waste and ventilation pipelines shall be tested by the Contractor at his own cost to detect leakages and any other defects in the pipelines. Test shall be conducted using proper apparatus with attachments for smoke making machine for applying smoke to the pipe lines under pressure. Only cotton waste or brown paper soaked in creosote shall be used and fired to obtain dense and pungent smoke. While conducting smoke test, top of soil, waste and ventilation pipes shall be kept open till smoke starts coming out of the openings. The openings shall then be securely plugged with expanding rubber or any other approved plug. The entire pipeline shall be tested in suitable sections as directed by the Engineer-in-Charge. The entire length of the pipeline including all joints under test shall be closely observed for any sign of smoke leakage. Any leakage and defects detected shall be rectified by the Contractor at his own cost to the satisfaction of the Engineer-in-Charge.

**24.7 Water Supply:-**

**24.7.1 Jointing and laying of galvanized steel water supply pipes:**

Screwed galvanized steel pipes shall be jointed with screwed joints and screwed fittings of

thesamematerials as that of the pipes. Any burrs remaining on the pipe ends after the threads are cut shall be removed. An approved jointing compound together with a few strands of fine yarn shall be used for jointing pipes and fittings. Any pipe threads exposed jointing shall be painted or in the case of underground piping thickly coated with approved bituminous compound to prevent corrosion. The depth at which the underground water supply pipe is to be laid shall be as shown on the drawings. The service pipe passing into or beneath the building shall be laid at least 200mm below the ground floor level and accommodated in the previously laid sleeve in the structure where it enters the building. The space between the sleeve and the pipe at its entry into and exit from the building shall be filled with a bituminous materials for a minimum length of 150mm at both ends. Piping shall not be buried in walls or floors as far as possible. However, when unavoidable, piping shall be buried for the shortest distance necessary and adequate protection shall be provided against damage. Galvanized steel piping shall be secured by iron or steel clamps and hooks when fixed on walls. All pipe work shall be completely watertight and the joints shall be such that there are no projections of jointing materials or the like in the interior of pipes. Before the pipeline is commissioned, all piping and fitting shall be flushed clean.

#### **24.7.2 Cleaning and disinfecting:**

All storage tanks, water supply fittings and pipes before being put into commission, shall be disinfected by the Contractor at his own cost.

#### **24.8 Installation of Sanitary Appliances:**

All sanitary appliances shall be fixed in position rigidly on floor and walls as shown on the drawings or as directed by the Engineer-in-Charge.

##### **24.8.1 Water closet:**

Water closet shall be fitted on the trap and shall be jointed with gasket yarn and cement mortar. Rim of the pan shall be leveled properly and set flush with the finished floor. The pan shall be connected to cast iron high level pull and let go or cast iron low level push down type flushing cistern /PVC cistern of capacity as indicated in the bill of quantities. The flushing cistern shall be supported on a pair of CI cantilever brackets firmly embedded in the wall in cement mortar (1:4) or screwed to wall with suitable plugs. Height of the bracket from the top of pan shall be as shown on the drawings. The flush pipe from the cistern shall be 32mm dia tested quality galvanized steel pipe (light) or HDPE pipe and connected to the pan inlet by means of hemp and putty joint.

##### **24.8.2 Urinals:**

Urinals shall be firmly fitted on finished wall by means of 50mm long brass screws and suitable plugs. Height of the lip from the standing point shall be as shown on the drawings. Urinals shall be fitted with cast iron automatic flushing cistern of capacity as described in the bill of quantities and as shown on the drawings. Flushing pipes shall be of galvanized steel pipes of required sizes and connected to the urinal with 15mm dia lead connector fitted with brass cap and lining at one end.

The joint to the inlet of urinal shall be neatly finished with putty joints. The arrangement of waste pipes and discharge to the floor trap shall be as shown on the drawings or as directed by the Engineer-in-Charge. For single urinal the discharge may be direct to the floor trap through a 40mm dia lead pipe or HDPE pipes as indicated in the drawing. For a range of urinals, the discharge may be collected in a common galvanized steel or HDPE pipe of 50mm dia leading to the floor trap.

Each urinal shall be connected to the common discharge pipe by 40mm dia lead or HDPE pipes. Alternatively, the discharge from each urinal through 40mm dia lead pipe shall be led to half round channel laid on the floor leading to the floor trap as shown in the drawing.

##### **24.8.3 Wash hand basin:**

Wash hand basin shall be fitted in position on true level on a pair of cast iron brackets rigidly fixed on wall with 50mm long brass screws and suitable plugs. The basin shall be fitted with 15mm dia. approved quality chromium plated pillar tap and 32 mm dia. waste fittings.

##### **24.8.4 Mirror, towel rails, soap tray and other miscellaneous fittings:**

Mirror, towel rails, soap tray and other miscellaneous fittings shall be fitted and fixed in position true to line, level and plane as per requirement and direction of EIC.



## **DETAIL SPECIFICATION OF WORK**

### **A) SPECIFICATION FOR THE WORK OF DESIGN & CONSTRUCTION OF COLLECTOR WELL AND CONSTRUCTION OF M.S ACCESS BRIDGE:**

#### **1. CONCRETE:**

All concrete construction shall be done in accordance with the specification for reinforced cement concrete and shall be in accordance with I.S. 456-2000. The concrete to be used shall be of the specified proportion or quality as given in the Tender Document or as directed by the Engineer - in-charge.

#### **2. CUTTING EDGE:**

The cutting edge shall be fabricated from the steel sections specified in the approved drawings. The steel sections shall not be heated and forged into shape and shall be cold bent and pressed in shape, if necessary 'V' cut may be made and shall be electrically welded after bending in the required shape.

The cutting edge shall be placed at the correct location and shall be levelled before building the well curb. For placing in water, where depth of standing water is less, simple sand islands may be prepared by laying a few rings of sand bags.

For laying in water, where depth is 1 to 5 meters. a sand island may be made by driving sheet piling and filling inside or by driving two rings of poles with their inside filled with sand bags or other materials and the central space being filled with sand. The size of island shall be sufficient to allow free working space necessary for various purposes and adequate protection shall be provided to prevent the island from scour.

#### **3. LAYING WELL CURB AND STAINING.**

Outer diameter of the cutting edge and curb shall be larger than the staining diameter by about 100 mm to lesser the frictional resistance in sinking. The curb shall be of cast in reinforced cement concrete of specified proportion and the concrete work shall be as specified under proper head.

The curb shall be of RCC of specified proportion and the concrete work shall be as specified under proper head. The curb shall be leveled fully and placed in exact position before the staining is commenced. The inside form work of curb for reinforced cement concrete shall not be removed before the expiry of seven days after laying the concrete.

In order to obtain perfectly vertical descent surface and to enable the direction of sinking of the well to be easily operated, the first height of staining shall not exceed 2 meters and 2nd height 2.5 meters, subsequent heights shall be built to convenient heights not exceeding the diameter of the well. The staining shall be carried up truly vertical and central over the curb, leaving the outer margin, as mentioned above. The staining shall be built in one straight line from bottom to top. In no case shall it be built in plumb at an intermediate stage when the well is tilted. Thickness of the staining shall be as specified. Plastering may be done at the cost of contractor if desired by him to facilitate sinking. **Note:** The height of the staining shall be marked continuously from bottom of cutting edge in meters painted in black oil paint both sides and outside of staining to record the well depth as the sinking work progresses.

#### **4.0 SINKING:**

The sinking of the well should be done in such a way that the well does not get out of plumb beyond the specified tolerance as per IRC code.

After the staining has been built up to a height mentioned above and has set and is sufficiently strong to withstand loading and accidental shock, excavation either manually or mechanically shall be started inside the well and below the curb. If by this excavation well does not sinking by its own weight a temporary loading platform shall be constructed on top of staining. Load may be applied in the form of gunny bags filled in with sand or in any other manner, subject to approval of the

Engineer-in-charge. The load shall be put on the outer edge of the platform leaving sufficient clear space in middle for lifting the excavated material by means of pulley, arrangements on shear legs or by means of grab and crane. The equipment shall be arranged for by the contractor as required and approved by the Engineer-in-charge.

Where boulders or pieces of rock are met with, it shall preferable being broken by a chisel or by any other suitable means. Generally speaking blasting shall not be permitted. Where blasting is absolutely necessary, the type and extent of charge used in each case shall be determined by the Engineer-in-charge and will be permitted as a special case only.

The well shall be kept absolutely plumb as far as possible during sinking operations and in case tilting occurs, the same shall be set right immediately by the contractor before proceeding further with sinking. In the final position a tilt of not more than 1 in 200 may be permitted.

If the well remains tilted or moves out of position due to any cause what so ever it shall be brought in position and made vertical by the contractor at his cost and risk.

As sinking proceeds, records of the different kinds of strata penetrated by the well shall be kept by preserving suitable sample.

#### **5. BOTTOM PLUGGING:**

The bottom of the well should be cleaned of unwanted materials before plugging is started.

The concrete of specified mix and conforming to specification shall be deposited to required height in well. If concrete is deposited under water care shall be taken to ensure that cement is not separated

from aggregate. The method adopted for concreting should be such that sound concrete is obtained, in

any method adopted the concrete should be placed at the bottom from a small height and should in no

case be dropped from a height more than 1.2 meters.

The concrete for plugging should be done in one continuous operation. After depositing, concrete shall be allowed to set at least for 14 days, the water shall not be pumped during this period. The plug shall then be tested by pumping the well dry, if leakage be found during the pumping suitable remedial measures shall be taken as prescribed by the Engineer-in-charge / consulting Engineer by the contractor at his cost.

#### **6. PLACING CONCRETE UNDER WATER:**

Placing of concrete under water shall be placed by means of minimum 250 mm dia. tremie pipe with facility of its movement by crane as per IS code. The concrete shall not be puddle when placed under water. The concrete shall contain at least 10% more cement than the required quantity for same mix in

dry condition.

##### **Specification:**

##### **Materials: Structural steel.**

All structural steel shall comply with the requirements of I.S. 226-1961 and I.S. 1915 -1962 specifications with latest amendment if any for structural steel appropriate for bridge work.

##### **Steel for pins and rollers.**

Rolled steel pins and rollers, shall comply with requirements of the I.S. —specification with latest amendment if any appropriate for the work. Steel casting for cast steel pins shall conform to grade 1 or 3 I.S. 1030 — 1956 specification with latest amendment if any for steel casting (for general engine ring purposes as appropriate).

##### **Bolts and nuts:**

Mild steel for bolts and nuts when tested shall comply with I.S. 1608 — 1960 with latest amendment if any and shall have tensile strength of not less than 44 Kg per sq. cm. Plain washer shall be made of steel.

**Welding Electrodes:**

Mild steel electrodes shall comply with requirements of I.S. 1814 — 1957 specification with latest amendment if any for covered electrodes for metal arc welding of mild steel.

**Workmen ship:**

All work shall be in accordance with the approved drawings and satisfy I.S. specification No. 1915 — 1961 with latest amendment if any. Care shall be taken to ensure that all parts in assembly fit accurately together. Notes or specification on the drawings approved by the Engineer-in-charge / Consulting Engineer, are to be constructed as superseding or cancelling any clause of this specification with which they conflict. On all drawings dimensions shown in figure shall be acted in preference to measurement by scale. A large-scale drawing, supersedes one or smaller scale.

**Straightening:**

All structural steel members and parts shall have straight edges. All straightening, shaping and leveling etc. shall be done by pressure only and not by hammering. All joggles and knees shall be formed by pressure and where practicable by making these, the metal shall not be cut and welded.

**Cutting:**

All structural steel parts required shall be sheared, cropped, sawn or flame cut and ground accurately to the required dimension and shape.

**Bolt Hole:**

The diameter of bolt holes shall be 1.5 to 2 mm. larger than nominal diameter of bolts. All holes or bolt shall be drilled unless permitted by engineer in Charge (EIC) for punching the holes. Care shall be taken that surrounding materials is not deformed or damaged in case punching the hole is allowed.

**Welding:**

Welding of steel conforming to relevant I.S specification with latest amendment shall be in accordance with general requirements of metal and welding. In addition to general requirements, the following care should be taken.

- (a) The welding shall be positioned for down wards whenever practicable.
- (b) The welding current shall conform with respect of voltage and amperage to the recommendation of the manufacturer of electrodes being used. The length arc voltage and amperage shall be situated to the thickness of materials, the type of grooves and other circumstances required for the Works.
- (c) The surface of the welded and the surrounding materials for the distance of the at least 155 mm. shall be free from scale, dirt, grease, paints, heavy rust or other surface deposit.
- (d) Members to be welded shall be held in correct position of holes, clamps, wedges, jigs or other suitable devices or by tack welding until welding has been completed, such fastening may be used shall be adequate to insure safety. Suitable allowance shall be made for warpage and shrinkage.
- (e) Tacks welds located where the final welds will later be made shall be subjected to same quality requirement as final welds defective and broken tacks weld shall be removed before final welding.
- (f) Fusion faces shall be cut by shearing, chipping or machining or gas cutting.
- (g) Exposed faces of weld shall be made reasonable smooth and regular so as to conform as closely as practicable to design requirement and shall not be of less than required cross section.
- (h) Welds showing slag or lack of proper penetration shall be cut out or rewelded.
- (i) Finished welds and adjacent parts shall be protected with clean boiled linseed oil after all slag has been removed.

**Safety precaution:**

- a) Operators of welding and cutting equipments shall be protected from the rays of arc flame by gloves and by helmets, and hand shields or goggles equipped with suitable filter lenses.
- b) Closed space shall be ventilated properly while welding or cutting is being done therein.
- c) Welders should be provided with such stages as well enable them to perform the welding operation.

For site welding shelter to be provided to protect the welders and the parts to be welded from weathers.

The contractor shall employ a competent welding supervisor to ensure that the standard of workmanship and the quality of materials comply with requirements laid in this specification. The contractor shall provide free access to the representative of EIC / consulting engineers to the work being carried out at all reasonable times and facilities shall be provided so that during the courses of welding, he may be able to inspect any layer or weld metals.

He shall be at liberty to reject any materials that does not conform to the terms of the specifications and the defective welds to be cut out and rewelded. The representative of the EIC / consulting Engineer shall be notified in advance of any welding operation.

Inspection and testing of welds shall be done as laid down in IS 822 and IS 1024. No welder shall be employed in any position except those who are fully qualified to weld. Qualification for welders shall be as laid down in I.S. 817.

**Joints:**

All steel work intended to be bolted together in must be in contact over the whole surface. Joints which have to compressive stresses and the ends of all stiffeners shall meet truly over the hole of the huffing surface and bear tightly top & bottom.

**Assembling:**

All member shall be so arranged that they can be accurately assembled without being unduly packed strained or forced into position and when built, shall be true to line and free from twist, kinks, bulks, or open joints between component piers. Work shall be kept properly bolted together and not drifting shall be allowed except for the purpose of drawing assembled section to gather slid in accuracies in matching of holes may be corrected. But drifting to enlarge holes is prohibited. Failure in any of the above respect will involve the rejection of defective members.

**Laying out:**

As far as possible structures shall be drawn out to full size on a level platform, with a steel tape and an

accurate square being used for lying out. The members shall be drawn and the joints arranged as shown

in the approved drawings.

Wooden templates 1/2" to 3/4" inch (12 to 20 mm) thick shall be made to correspond to each member and plate and bolt holes marked in them accurately by drilled holes large enough to fit the marking punch accurately. Templates for plates may be made of sheet metal. In case of repetitive work all templates shall be of steel. For accurate and mass drilling of holes, jigs fitted with drill bushing shall be used.

**Erection:**

Columns and struts be erected in plumb and to centres and levels. Proper derricks and suitable lifting tackles at such points that they are not liable to get buckled or deformed. Trusses and frame girders shall be lifted at two points about 1/3 to 1/4 length along each span from the ridge or centre.

Immediately the frames or trusses are placed in position, they shall be secured against overturning. Every precautions shall be taken to prevent toppling. In case of trusses, all wind bracings shall be placed at the same time as the trusses are erected. The method of hoisting, erection and launching proposed to be adopted shall be got approved from the Engineer —in — Charge / Consulting Engineer.

The approval of the ETC, however shall not relieve the contractor from his responsibility for the work being carried out in safe and proper manner without unduly stressing the various members.

Proper and

adequate plant such as lifting tackles, winches, ropes etc shall be used.

**Finishing:**

Before member of the steel structure are placed in position or taken out of workshop, they shall be thoroughly cleaned of dust, loose scales etc. and given one coat of red lead paint, subsequent coats shall be applied after all the members are fixed in position finally.

**Painting:**

After all members have been given initial coat of red lead, they shall be given two coats of approved paint when fully installed.

**Measurement:**

Rate for the rolled sections lengths shall be for unit of one tonne. In case of rolled sections length shall be measured correct to a centimeter and weight calculated on the standard weight per meter tabulated in IST Hand book for structural steel sections limited to the length shown on the plans. Weight of steel plates of each thickness shall be calculated separately on the basis of actual shape provide without taking into account wastage of cut off.

**DETAILED TECHNICAL SPECIFICATION****1. Grade of concrete for different works: -**

The grade of concrete for the collector well right from cutting edge, steining wall, working platform and up-to the floor of pump house shall be of M30 design mix concrete. Then onwards, the grade of concrete work will be of M 25

The grade of concrete for the supporting piers, abutments, pier caps, pile caps, and deck slab / beams/ railings, etc. relating to the approach bridge will be as per relevant IRC / IS Code of practice. Execution of work shall have to be carried out according to the stated grade / mix on the approved design as per the relevant code of practice and specifications enclosed.

**2. Cofferdam / Island:**

In case of necessity, the cofferdam or Island may be constructed with an enclosure built around the location of the collector well or foundation well of each pier of gangway with timber/ ballah/ sheet piling whichever is found suitable to provide adequate space for carrying out the foundation work. The space inside the piling work may be filled with earth and raised above the water level over the bed to a height required for construction of the foundation work. The contractor shall quote his rate keeping in the view of this provision.

The provision should include the cost of bailing out and pumping out water from the cofferdam during laying of the foundation wells of collector well, piers and abutment etc. as required during the entire actual excavation or foundation work. The bailing out of water includes completed dewatering by any convenient methods by employing pumping sets of required capacity in working condition with all accessories to run the sets as required from commencement to completion of the work and until the foundation structure is completed all the trenches for foundation shall be kept free from water till the concrete in foundation reaches initial setting.

The contractor on receipt of work order shall submit the drawings showing the details of his proposed method of construction of cofferdam or islanding and other design details for approval of the Engineer — in — Charge or the Departmental Design wing whenever necessary.

The cost should include the cost of construction and maintenance of any cofferdam, bunds, dams, canals or other devices necessary for diverting the flow of water on any such item of any sort whatsoever required to prevent water disturbing the work. No extra cost will be paid for any sand / earth / stuff of any sort which might find access by blowing or for any other reasons whatsoever from the sides or bottom of foundation or from elsewhere when dewatering operations are in progress. The contractor shall arrange for all necessary plants, pumps, engines and machineries tools and plants as required in this connection. The coffer dams constructed have to be maintained for more than one working season in the event the

foundation and substructure work being not completed in a single working season. He should keep provision in his quoted amount for reconstruction of cofferdam as per requirements for any subsequent working seasons, if necessary. No extra payment will be made for increase of work due to any additional requirements.

### **3. Cutting Edge:**

Diversion of watercourse if necessary for setting out / casting / construction of cutting edge will have to be done by the agency at his quoted amount. The mild steel to be used shall be "Tested" steel complying with IS: 226 — 1958 with latest amendment if any, for structural steel. The angle, R.S. Beams, channels, Tees, Flats, etc shall comply with IS 808 — 1957 with latest amendment if any. The cutting edge shall be fabricated of the exact shape and dimensions shown on the detailed drawings. The steel section shall be bent cold to the required shape by making V-cuts in the horizontal portion at not less than eight places for a single well and at equal intervals along the length.

The V-cuts shall be then welded together electrically by gas welding bending steel section by heating and forging is not permissible. If any reworking is done, the steel used for rivets shall comply with IS: 1148 specification with latest amendment if any, for rivets bars for structural purpose. Holes shall be drilled on the horizontal portion at the exact points shown in the detailed drawing for fixing the vertical ties rods of the RCC curbs. Except as otherwise specified herein the fabrication shall be done in accordance with IS: 800-1956 code of practice with latest amendment if any, for use of steel arc welding for general construction in mild steel. After fabrication etc. is completed, the cutting edge shall be conveyed to the spot where it is to be laid and which has been previously excavated to required level and nearly levelled. It shall be oriented and set in the exact position required.

The job includes all materials, plants, labour etc. required for the work. The fabricated cutting edge shall be lunched by the usual method as approved by the Engineer-in-charge to the site where it is to be set. The rate includes welding (electric or gas), riveting, jointing cost of materials. The contractor shall have to arrange at his quoted cost and risk for procuring all the materials, steel sections as per IS specification and tested as per detailed design and drawing approved. No extra payment will be allowed for jointing, welding, reworking or 'wastage and the quoted rate must include all necessary steel for fabrication including setting out the steel cutting edge at site for RCC curbs as per approved drawing and design complete. The level at which the bottom of cutting edge is placed will be the subsoil water level. It will be this level that payment will be made for sinking.

### **4. M-30 Grade Design Mix Cement Concrete:**

The work shall be done as per clause no 301 to 322 of IRC code of practice and standard specification for road bridges, section No. — III for concrete work of this grade of concrete. Cement, coarse, fine aggregates and water provided by the contractor shall conform to the specification of clause No. 301 to 322 of IRC code — III. The maximum size of coarse aggregate shall not be more than 15mm.

All materials shall comply with the standards laid down in IS: 456-2000 (Revised) with latest amendment if any, and IRC code of practice and standard specification for road bridge section — III. For the purpose of proportioning by volume 1 cum of cement shall be considered as to weigh 1440Kgs. (90 lbs / cft). The strength of concrete in work shall be determined from the result of tests on standard 150mm work test cubes as per I.S:456-2000 (Revised) with latest amendment if any. The test specimen taken directly from batch concrete in actual use shall be compacted and cured under similar conditions.

The contractor shall furnish necessary concrete and the steel moulds for making the test specimen, materials and equipments and labour necessary for transportation, curing and storage and necessary testing at Govt. recognized laboratory at his own cost. The minimum cube strength of the test cube taken from the work concrete shall as per specification at 28 days and 7 days respectively. In case the overall strength of concrete is less than 70 percent of the desired strength, the corresponding work already done shall be liable to summary rejection and the contractor shall have to replace the rejected work at his own risk and cost to the satisfaction of the Engineer — in — Charge.

In case the overall strength lie between 70% to 100% suitable reduction in cost may be done by the Department as decided by the Engineer-in-Charge.

All concrete shall be thoroughly mixed in mechanically operated batch mixer of approved type and capacity. Hand mixing of concrete shall not be permitted.

Concrete shall be deposited in condition horizontal layers in thickness not more than 400mm.

Not more than one hour shall lapse between placing of next layer of concrete. Concrete shall be placed in its final position compacted and finished within 30 minutes of mixing the water and before setting commences. The construction joints when required shall be made where location on plan are shown unless otherwise approved by EIC. Before commencing subsequent concreting, all loose particles shall be removed and the surface shall be covered by thick cement mortar/ slurry. Before placing of concrete on hardened surface, it must be cleaned, roughened without dislodging coarse aggregate, thoroughly wetted and covered with 6 mm thick mortar layer composed of cement and sand in same proportion as in the concrete for securing good bond.

During and immediately after placing the concrete, it shall be thoroughly compacted by using mechanical vibrators of adequate number to achieve compaction at the same rate of placing. The frequency of the vibrators shall not be less than 4500 cycles per minute, when operating under load. Ordinary method such as ramming, tamping, rodding and slicing etc. with suitable tools shall be used as supplementary to mechanical vibrators only but not replace it.

Concrete shall not be placed during rain, high wind, dust storm and excessive heat.

Concreting when continued beyond day light hours, the site should be sufficiently lighted.

#### **5. Curing:**

Curing shall be done by sweet portable water. Exposed surface of concrete shall be protected by covering with canvas, straw etc. and kept moist by flushing or sprinkling water and shall continue not less than 14 days after concreting.

#### **6. Form work and shuttering:**

It should be so designed as to prevent leakage of cement slurry from concrete and to maintain accurate alignment and surface as per relevant IS code of practice. Form work shall not be removed unless permitted by EIC and may be removed with adequate care when the EIC permits to avoid damage to the concrete.

The design of the forms of steining wall shall be such as to build the steining in the convenient numbers of lifts not exceeding 1.5m in height. The height of each course of concreting shall be uniform so that height of steining at all points is same and thereby a level construction joint is assured. The steining of well to be built up shall be checked carefully with the help of straight edge so as to ensure all the faces of the wall to be parallel to the vertical axis of the well. The contractor shall maintain adequate sets of form work to maintain adequate rate of progress.

#### **7. Gauges:**

Three gauges shall be provided at equal interval along the periphery on each well to show the height of the steining. Each gauge shall consist of 75 mm wide painted with enamel paint on outside face of the steining parallel to the vertical axis of the well. The zero of the gauge shall start from the bottom of the cutting edge. The gauge shall be marked very carefully at every meter height with sub-divisions of ten centimeter using a steel tape all along under the supervision of the EIC.

Permanent pillars or pegs along the two-perpendicular axis on all four sides of each well shall be maintained well outside the zone of disturbance or sand blowing for facility of checking tilt or shift of the well with progress of sinking of the well. One of the two axes must coincide with the centreline of the approach bridge from the collector well to the bank abutment. The lifts of the steining and that of the piers shall be so arranged as to attain same design datum height for each well and piers.

#### **8. Sinking of Wells:**

##### **Specification:**

(a) This item includes sinking of wells for foundation through sand, loose boulders, silt clay soft and hard morum, and all such other similar strata to the required level as may be directed by the Engineer — in — Charge including removal of excavated stuff, isolated boulders and trees logs or any other similar objects and adopting for this purpose suitable methods such as open dredging or technical grabbing by using winches including use of drop employing of drivers including pneumatic drilling for breaking and removing loose isolated boulders and all such other method of well sinking. The method to be adopted for sinking wells shall be first got approved from the Engineer-in-charge. For any change in the method required during execution, the contractor shall first obtain the written

permission of the Engineer-in-Charge. Before laying the steel cutting edge, casting the curb and commencing sinking open excavation shall be carried out in the river bed or bank or artificial islands as the case may be, so that the cutting edge is laid at the sub-soil water level or wherever possible below that level if the inflow of water is not enough to permit excavating below that level. Before commencing sinking of the well the level at which the cutting edges laid (which shall not be ordinary above the sub-soil water level) shall be recorded by the Engineer-in-charge or his representative in levelling field book and the entry counter signed by the contractor, his resident Engineer or his authorized representative in taken of his acceptance. Sinking shall not be started till the concrete curb and steining to the required depth for the first stage have been cast, cured and allowed to attain the required strength.

The sinking shall be generally done by removing the materials inside the dredged holes and by applying kentledge when necessary. Dewatering of the well shall be discouraged and shall not be done unless (a) the well has been sufficiently sunk or has passed through a clay stratum, so that chances of tiles and shifts are minimized.

(b) Previous permission of the Engineer-in-charge has been taken, if there is any tendency to sandblowing dewatering shall be carefully observed for any subsidence which will indicate sandblowing. After the well has been sunk to long depth dewatering shall not be restored to unless grabbing chiseling, applying Kentledge etc. fail to sink the well. In this case, dewatering may be permitted up to maximum depression head of 6.0 m only. If a well gets struck and does not sink by normal methods, water jetting on the outside of the steining may be done after obtaining permission of the Engineer-in-charge.

Utmost care shall be taken from the commencement of sinking operation to ensure that the well is continuously kept perfectly vertical at all times and depths, checking frequently with plumb hanging on the inside surface. The materials from inside the well shall be methodically excavated evenly over the whole internal area, excavating first in centre and then working towards the circumference in all directions. The levels of the excavation in well shall be constantly checked so as to keep the bottom as nearly in level as practicable. It is of a great importance that the curb at the few metres lengths of well steining shall be kept perfectly vertical and never allowed to go out of place or plumb materially so as to assume subsequent sinking of well correctly to plumb and in the designed position. The removal of excavated stuff, isolated boulders etc. shall be carried out as per the direction of Engineer-in-charge and shall be deposited at the place or places with all lead and lift in such a way as not to interfere with the free flow of water in channel. At all subsequent stages of the sinking the well shall be maintained in the true vertical position without any eccentricity from the designed centre lines as far as practicable. A temporary frame work shall be provided to guide the sinking in initial stages. The verticality shall be frequently checked with plumb bobs along the inside surface of the steining after first making sure with the help of straight edges that the steining itself is straight in a vertical direction. The maximum allowance of tilt and shift in well shall not exceed the following limits. The completed well shall not have:

- i) A tilt more than 1 in 60 in any direction.
- ii) A shift more than 200 mm at the top from designed vertical axis of the well in any direction. Any tilt and or shift beyond the permissible limit referred to above, shall be removed by all available means such as structure accepting Kentledges railing by wire ropes or by any other approved method.

If under any circumstances, the tilt and shift exceed the above limit for any well, but do not exceed the extreme limits of 1 in 40 tilt and 400 mm shift in any direction.

If the tilt and shift exceed the above limit for any well, the well shall be liable to rejection at the direction of the Engineer-in-charge and or the shift more than the specification above, which cannot be corrected, the dimensions of the concerned well shall be suitably increased so as to cover completely the well top and also allow the pier to be located symmetrically on the well cap provided that the stresses at the foundations of the well can be brought within the permissible limit by suitably shifting the position of the pier to overcome the effect of tilt and shift.



No payment for any increase in the dimensions of the well cap and M.S. reinforcement herein shall be made. If even with adjusted location of the pier and increased dimensions of the well caps, the stresses at the foundation level due to tilt and /or shift cannot be brought within permissible limits, the contractor shall rectify the well or reconstruct the same at his own cost. In this event, the contractor shall also bear the extra cost resulting from any change in the design, span length etc. due to such fault of well. The cost of the cement and steel supplied to the contractor and used in the rejected well as in the new well laid in its place shall be recovered from him.

Every well started during any working season must be completely plugged, filled with sand and sealed with top plug and well cap at the top within that working season so as to be safe from flood and tides as far possible. If the sinking of the well up to the designed or required level, plugging it at bottom and top, sand filling and concreting the well cap can not be completed in one working season the following 'precautionary measures shall be taken by the contractor at his own risk and cost.

All exposed reinforcing bars shall be carefully down along the steining and temporarily embedded in lean concrete 1:4:8. The dredged area shall be filled up with the sand right up to the top of the well steining at no extra cost and suitably covered up with adequate wooden planking or by any other method approved by the Engineer-in-charge.

The above measures shall not however, absolve the contractor from any responsibility in the event of any damage occurring to the incomplete well and he shall have to rectify the same at no extra cost, to the entire satisfaction of the Engineer-in-charge.

The foundation levels as shown on the detailed drawing are tentative and are not taken as firm but are liable to alteration by Engineer-in-charge depending upon the actual site condition by ones and as required by the circumstances. The decision of the Engineer-in-charge regarding the foundation and its variety one during deduction of the work shall be binding on the contractor.

#### **9. Measurement of well sinking: -**

Sinking of well shall be measured in meters correct to 5 mm from the water level at the time of casting the curb or from the level at which the bottom of cutting edge is laid initially whichever is lower, to the bottom of cutting edge in final position. The water level at the time of casting the well curb and the bottom of the cutting-edge level shall be kept recorded by the department duly countersigned by the contractor.

In case the well curb is cast on island or at higher level than the water of the bed due to unavoidable reasons, the sinking of the well will be counted from the initial level of the cutting edge to final level reached by the bottom of the cutting-edge initial level of the cutting edge shall be taken as zero level in this case.

All the cost of materials, labour, machinery and other equipments shall be included in the quoted rate under specification.

#### **10. Well plugging:**

The well plugging of the collector well is of vital importance and the plugging of the bottom of the collector well need be so done that complete dewatering of the well can be done after completion of plugging to enable working men to push the strainers into aquifer at pushing from inside the dewatering well safely. The well plugging therefore shall be of adequate thickness made of M20.

The contractor shall show the detailed designed calculation to justify the thickness of well plugging to be provided in well. In addition to this plugging by mass concrete under water, an RCC raft concrete of adequate thickness shall be laid over the plain concrete well plugging to make the well perfectly water proof. This RCC raft shall be inserted into a previously kept peripheral groove of adequate horizontal depth and of height to accommodate the full thickness of the raft duly designed to withstand the upward pressure it will likely to resist at the time when the well is kept empty inside. This RCC raft also shall be of M30 (design mix).

Port holes at appropriate level of required size / dia. and spacing has to be kept in the steining of well as per drawing / direction of EIC. Testing of water tightness of the well from inside the well in phased manner under normal condition of water outside. Any leakage if detected has to be rectified by the contractor by suitable method. He should keep provision for all these works including cost of materials, labour and tools and plants in his quoted rate / amount. Dewatering the collector well at the time of high flood should not be done.

#### **11. Casting of piers over pile foundation.**

The piers of each well foundation caps are to be constructed with required reinforcements and grade of concrete as per IRC / IS code of practice and approved designed drawings. Cost of all materials, tools and plants, labour and equipments and reinforcements, scaffolding, centering, shuttering, vibrating curbing etc shall be included in his quoted rate / amount. Measurement to be taken in cubic meters.

## **12. Pier caps**

Pier caps over each pier shall have to be constructed as per approved detailed design and drawings are as per relevant IRC / IS code.

## **13. Abutment wall and wall cap: -**

Abutment walls and wall cap shall have to be constructed as per detailed drawing using grades of concrete as provided for different components including providing seepage holes and placing filter media behind each hole for easy passage of seepage water including foundation excavation shuttering shoring bailing out of water etc. all complete within the rate quoted by the contractor as per IRC /IS code including labour & materials.

## **14. Steel / Tor steel reinforcement.**

The relevant clause of the standard specification of steel for concrete reinforcement of IS: 432 — 1960 and 456 — 2000, SAIL, TATA TISCON or RINL shall be applicable as per detailed drawings of each RCC work to be done for each component of the collector well, pile foundation, piers, abutment, superstructure of approach bridge, etc. including transporting, placing, assembling, tying with wires, cutting to sizes, hooking bending & embedding in concrete including cost of labour, materials and tools and plants. Fixing and binding of rods with 16-gauge wire shall be strong enough to keep in position during lying and vibrating. Adequate cover shall be maintained by using precast mortar blocks of appropriate size and mix. Measurement shall be taken on the basis of weight derived from length of MS bars actually placed with nos. of laps and hooks as per design and drawing approved by EI. Weight of binding wire shall not be counted for measurement for payment.

## **15. Earth filling behind abutment.**

Earth filling shall be done with good earth available from borrow pits. Filling shall be done in layers not exceeding 30 cm and it will be watered adequately, all rammed and consolidated. No lumps, clods or rubbish are to be used. The cost of transportation of excavated earth, filling in layers, flooding with water, levelling, compacting etc. shall be included in his quoted rate amount.

## **16. Filter Media behind weep Holes of abutment:**

The backside of the weep holes of abutments shall be filled with black, hard stone of 40 mm size as per drawing for easy draining of seepage water from the back fill. The cost shall be included in his quoted rate / amount.

## **17.0 Bearings of steel Bridge and steel super structure of approach Bridge.**

The superstructure of the approach bridge shall be of simply supported steel trusses or R.S. Joists as required and shall rest over the piers on bearings as per standard method, approved detailed drawing and relevant IRC / IS code of practice. Hoisting, fixing, holding the truss / beams is to be done carefully with approved type of hoisting machine, and tools and plants for safe hoisting and fixing. Once the truss is hoisted, it has to be fixed with holding down bolts and restrained by fixing with horizontal member of beams and bracings top and bottom to prevent any lateral movement thereafter. Any accident if caused due to negligence in proper hoisting arrangement and fixing in position, the contractor is liable to compensate the damage of structure or life of working men at site at his risk and cost. The execution of the steel superstructure has to be done as per approved detailed drawings and relevant IRC / IS code of practice.

The deck slab may be precast R.C.C. slab or cast in situ R.C.C. of adequate thickness and duly reinforced to carry the loads it has to sustain during transportation of pumps and other machineries and also day today dead and live load and other types of loads that may act upon it. The quoted rate / amount should include all the cost of materials, labours and tools and plants needed for the execution of the work.

## **18. Fabrication, fixing, welding M.S.**

### **sections: Materials: Structural steel.**

All structural steel shall comply with the requirements of **IS. 226-1961 and I.S. 1915 — 1962** specification with latest amendment if any for structural steel appropriate for bridge work

### **Steel for pins and rollers.**

Rolled steel pins and rollers shall comply with requirements of the I.S. — specification appropriate for the work: Steel casting for cast steel pins shall conform to grade 1 or 3 I.S. 1030 — 1956 specification with latest amendment if any for steel casting (for general engine ring purposes as appropriate).

### **Bolts and nuts:**

Mild steel for bolts and nuts when tested shall comply with I.S. 1608 — 1960 with latest amendment if any and shall have tensile strength of not less than 44 Kg per sq. cm. Plain washer shall be made from steel.

### **Welding Electrodes:**

Mild steel electrodes shall comply with requirements of IS. 814 — 1157 specification with latest amendment if any for covered electrodes for metal arc welding of mild steel.

**Workmen ship.**

All work shall be in accordance with the drawings and satisfy I.S. specification No. 1915 -1961 with latest amendment if any. Care shall be taken to ensure that all parts in assembly fit accurately together. Notes or certification on the drawings submitted by the designers and approved by the department shall be capable of superseding or cancelling any clause of this specification with which they conflict. On all drawings dimension shown in figure shall be acted in preference to measurement by scale.

**Straightening.**

All structural steel members and parts shall have straight edges. All straightening, shaping and levelling etc. shall be done by pressure only and not by hammering. All joggles and knees shall be formed by pressure and where practicable in making these, the metal shall not be cut and welded.

**Cutting:**

All structural steel parts where required shall be sheared, roped, sawn or flame cut and ground accurately to the required dimension and shape.

**Bolt Hole:**

The diameter of bolt holes shall be 1.5 to 2 mm. larger dimensional diameter of bolts. All holes or bolt shall be drilled unless permitted by engineer in Charge (EIC) for punching the holes. Care shall be taken that surrounding materials is not deformed or damaged in case punching the hole is allowed.

**Welding:**

Welding of steel conforming to relevant I.S specification shall be in accordance with general requirements of metal and welding. In addition to general requirements, the following care should be taken.

- a) The welding shall be positioned for down wards whenever practicable.
- b) The welding current shall conform with respect of voltage and amperage to the recommendation of the manufacturer of electrodes being used. The length arc voltage and amperage shall be situated to the thickness of materials, the type of grooves and other circumstances required for the works.
- c) The surface to be welded and the surrounding materials for a distance of at least 155 mm. shall be free from scale, dirt, grease, paints, heavy rust or other surface deposit.
- d) Members to be welded shall be held in correct position by holes, clamps, wedges, jigs or other suitable devices or by tack welding until welding has been completed. Such fastening may be used shall be adequate to ensure safety. Suitable allowance shall be made for warpage and shrinkage.
- e) Tacks welds located where the final welds will latter be made shall be subjected to same quality requirement as final welds, defective and broken tacks weld shall be removed before final welding.
- f) Fusion faces shall be cut by shearing, chipping or machining or by gas cutting.
- g) Exposed faces of weld shall be made reasonably smooth and regular so as to conform as closely as

practicable to design requirement and shall not be of less than required cross section.

h) Welds showing slag or lack of proper penetration shall be cut out or rewelded.

i) Finished welds and adjacent parts shall be protected with clean boiled linseed oil after all slag has been removed.

**Safety precaution:**

- a) Operators of welding and cutting equipments shall be protected from the rays of arc flame by gloves and by helmets, and hand shields or goggles equipped with suitable filter lenses.
- b) Closed space shall be ventilated properly while welding or cutting is being done therein.
- c) Welders should be provided with such stages as will enable them to perform the welding operation. For site welding shelter to be provided to protect the welders and the parts to be welded from weathers. The contractor shall employ a competent welding supervisor to ensure that the standard of workmanship and the quality of materials comply with requirements laid in this specification. The contractor shall provide free access to the representative of EIC / consulting engineers to the work being carried out at all reasonable times and facilities shall be provided so that during the courses of welding he may be able to inspect any layer or weld to metals. He shall be at liberty to reject any materials that does not conform to the terms of the specifications and to require any defective welds to be cut out and rewelded. The representative of the EIC / consulting Engineer shall be notified in advance of any welding operation. Inspection and testing of welds shall be done as laid down in IS 822 and IS 1024. No welder shall be employed in any position except those who are fully qualified to weld. Qualification for welders shall be as laid down in I.S. 817.

**Joints:**

All steel work intended to be bolted together must be in contact over the whole surface. Joints which have to compressive stresses and the ends of all stiffeners shall meet truly over the whole of the huffingsurface and bear tightly top & bottom.

**Assembling:**

All member shall be so arranged that they can be accurately assembled without being unduly packed strained or forced into position and when built, shall be true to line and free from twist, kinks, bulks, or open joints between component piers. Work shall be kept properly bolted together and no drifting shall be allowed except for the purpose of drawing assembled section together slight inaccuracies in matching of holes may be corrected. But drifting to enlarge holes is prohibited. Failure in any of the above respect will involve the rejection of defective members.

**Laying out:**

As far as possible structures shall be drawn out to full size on a level platform, with a steel tape and an accurate square being used for laying out. The members shall be drawn and the joints arranged as shown in the approved drawings.

Wooden templates 12 mm to 20 mm thick shall be made to correspond to each member and plate and bolt holes marked in them accurately by drilled holes large enough to fit the marking punch accurately. Templates for plates may be made of sheet metal. In case of repetitive work all templates shall be of steel. For accurate and mass drilling of holes, jigs fitted with drill bushing shall be used.

**Erection:**

Columns and struts to be erected in plumb and to centers and levels. Proper derricks and suitable lifting tackles at such points that they are not liable to get buckled or deformed. Trusses and frame girders shall be lifted at two points about 1/3 to 1/4 length along each span from the ridge or centre. Immediately the frames or trusses are placed in position, they shall be secured against overturning. Every precaution shall be taken to prevent toppling. In case of trusses, all wind bracings shall be placed at the same time as the trusses are erected. The method of hoisting, erection and launching proposed to be adopted shall be got approved from the Engineer — in — Charge or his representative / Consultant. The approval of the EIC, however shall not relieve the contractor from his responsibility for the work being carried out in safe and proper manner without unduly stressing the various members. Proper and adequate plant such as lifting tackles, winches, ropes etc. shall be used.

**Finishing:**

Before member of the steel structure are placed in position or taken out of workshop, they shall be thoroughly cleaned of dust, loose scales etc. and given one coat of red lead paint, subsequent coats shall be applied after all the members are fixed in position finally.

**Painting:**

After all members have been given initial coat of red lead, they shall be given two coats of approved paint when fully installed.

**Measurement:**

Rate for the steel superstructure shall be for unit of one tonne. In case of rolled sections, length shall be measured correct to a centimeter and weight calculated on the standard weight per meter tabulated in ISI Hand book for structural steel sections.

Weight of steel plates of each thickness shall be calculated separately on the basis of actual shape provided without taking into account wastage of cut off. In case of bolt work, weight of bolts nuts and washers shall be added in full, no deduction shall be made for rivets holes. No increase in weight shall be allowed in welding work due to welding.

The rate should include supply, fabrication and erection in position at site of all structural steel sections required for all operations of fabrication, hoisting, erection and satisfactory completion of the item and all labour and materials etc. including painting the structural steel work.

**19. Precast or cast in site deck slab:**

RCC deck slab made of cast in situ slab of appropriately designed thickness in M20 (1:1.5:3) concrete shall be provided including cost of all materials, tools and plants and labour centering, shuttering, staging required for the cement concreting in accordance with relevant clauses in section III of the IRC code of practice and standard specification for road Bridges. Measurement of this item and payment shall be done in cubic meters.

**20. Wearing Coat:**

A wearing coat of cement concrete M20 (1:1.5:3) with proper cambering and of thickness as per IRC code of practice shall have to be provided as per direction of EIC including all cost of labour, materials,

and tools and plants needed for the work at his quoted rate / amount.

**21. Fabricating, providing and fixing M.S. Roller pipes:**

M.S. roller pipes shall be provided as per design and drawings cost of which shall be quoted as per number basis unless specified otherwise.

**22. Providing holes in steining wall of collector well for jack pushing of strainers:**

Holes of 515 mm dia. or as required dia. are to be provided radially in the steining during casting at prefixed levels at designed Centre to Centre spacing or as shown in the approved drawings for facility of subsequent pushing of radial strainers into the aquifer at desired level / as shown in the approved drawing or as decided by the EIC. The method may be as follows.

Make a hollow cylinder of timber of O.D. 515 mm and 1125 mm or as required long and place it in position truly horizontal and radial in the well steining as shown in the drawing before concreting. After two days of casting, the wooden cylinder may be pulled out leaving a hollow of 515 mm dia. and 1125 mm or so long into which a M.S. port hole is eventually fixed with grouting. It is through this port holes that the slotted pipes are driven.

**22.5 Providing and fitting Circular timber plate of 615 mm dia. (Dia. of hole + 2 X 50 mm) X 75 mm thick at the end of the hole before concreting.**

The timber plate is meant to prevent water entering the hole during sinking. It must be accurately centered in the hole at the outside and 50 mm from the outside surface of the well so that there is 50 mm of bearing on the whole periphery. The plate should not be rigidly fixed to the shuttering forming the hole, otherwise the hole shuttering cannot be pulled out.

**24.0 Providing, levelling, fixing and grouting 1:2 mix M.S port holes as shown in drawing, complete with rubber lining 12 mm thick properly fixed with adhesive.**

The M.S. port hole must be most accurately fabricated as shown in the drawing. The inside rubber lining of 12 mm thick must be rigidly fixed to the port hole with a special adhesive so that it can successfully resist the abrasion and shearing action of the slotted pipe that pass through it. Provision for levelling lugs to be made so that the port holes are aligned in the hole truly horizontal and radial. A long spirit level shall be placed in the bottom and packing in the levelling lugs may be so adjusted that the porthole is truly horizontal. Similarly, by tying a long string at the two ends in the centre of the hole, it should be checked that this string passes exactly to the centre of the well confirming the correctness of the radial position. It should be grouted only after its position in horizontal and radial direction is accurately confirmed. Grouting with 1:2 mix shall be done with a pressure head of at least 1 m, so that it passes right to the other end. The end of the steel port hole shall be covered with a plastic or timber plate so that it does not enter into the steel port hole from that end. Special care shall be taken to ensure that the annular space between the outer face of the steel porthole and the inside of the 500mm dia. hole in the steining is completely filled up with grouting. Pipes should not be driven through the portholes until 7 days have elapsed after grouting. All portholes in one tier shall be completely grouted and cured before pipe driving is started at all. This will automatically give extra curing time to all port holes except the first one.

**25.0 Fabricating, supplying cast steel bullet heads and welding to slotted pipes as shown in the drawing complete as directed.**

The tenderer shall show the detailed drawing dimension of the C.S head and its mode of fixing with the slotted pipes with specification for approval of the Department and work shall be carried out as per the said approved drawing.

This is first pilot piece that penetrates the aquifer and has therefore to be strong enough accurately made of cast steel. Before welding the bullet head to the first pipe, the nonreturn sand valve with the first pipe should be fitted by welding. Before fabricating slotted pieces, the first piece shall be got approved to see that it conforms accurately to the shape and size in the drawing got approved beforehand.

**26.0 Providing supplying stainless steel ribbed case slotted pipes of 400 mm internal dia. and 12mm or above thickness as required for withstanding thrust of horizontal jack pushing and driving through aquifer to required length.**

The stainless steel ribbed case slotted pipe shall be of 400 mm dia. and of thickness 12mm or above as required to withstand the applied thrust to push the pipe through the aquifer to minimum 40 (slotted portion) meter +10 (blind portion) meters i.e. 50 meters. The strength of the pipe to withstand the total

thrust shall be calculated on the actual net cross section area available after deduction the area lost due to slots in particular section.

The width of the slots shall be 1 mm or near about on outer surface. The opening of the slots in inner surface of the pipe shall be widened suitably to prevent entrapping of sand grains inside the slots. The area of perforation of the strainer shall be 16% at least.

The slot shown in the drawing is indicative only for guidance. The contractor shall have to get 2 pieces of pipes selected by the EIC tested at the institute or any reputed Govt. approved testing agency to study the area of perforation in %age method of failure and the maximum load withstanding capacity when applied over the cross-sectional area etc. and he has to abide by the test report. In case it becomes impossible for making the tapered slots as desired over standard stainless steel pipes available, the contractor shall have to fabricate the pipes out of stainless steel plates of appropriate thickness after making the slots on the plates as per requirement if the EIC so directs after considering all the available data and information.

The pipes shall be dipped into a bath of red lead paint. After the red lead paint dries, the process shall be repeated so that the pipes have two coats of paint. Each pipe shall be of uniform length of 1.20 m to 1.50 m each as suitable for horizontal jack pushing from inside the well. Each piece of the required nos. of pieces for each radial shall be pushed serially one by one for facility of measurement. The pipes must be marked with 18 mm wide yellow longitudinal strip of yellow paint at the centre of the sector with slots so that its correct driving position is indicated. The rate quoted should include the cost of materials and labour for slotting as specified or directed, fabricating, testing, pushing etc. all complete. Proportionate deductions shall be done as decided by EIC in case of failure of making inverted ribbed case / V-Shaped slots (slots enlarge towards inside of stainless steel pipes)

## 27.0 **Radial Collector Wells:**

A collector well consists of a cylindrical well of reinforced concrete min 6 m in diameter, going into the aquifer to as great a depth of the sub-strata as possible, i.e. upto an impermeable stratum. Normally the saturated aquifer should not be less than 7 m above the top of the radial pipes. From the bottom of the well, slotted stainless steel pipes, normally of 400 mm diameter on the inside & going upto 50 metres are driven horizontally. The length is determined by the composition & yield from the aquifer. The drain tubes are made up of short length of pipes each 2.4 m in length which are welded to each other electrically one after the other.

These steel pipes are driven horizontally into the aquifer by means of suitable twin jack placed in the well & crossing the staining of the well, through the special openings or port holes. At the same time, desanding operation is carried out through the head of the drain pipes. This operation is important & results in the removal of all the fine particles in the alluvium thus increasing the draw-off.

A sketch of a collector well is given in Appendix-5.7.

### (a) **Desanding Operation while Driving Radials**

An important operation in the driving of the drains is the operation of desanding of drain tubes of 400 mm dia which will remain inside the sand bed being driven to a certain distance. An inner tube is then introduced into the drain which is used for sending a blast of compressed air for loosening & separating the fine particles of the alluvium at the head of the drain. When the compressed air is turned off, the pressure of the water, due to the head of the water table, enables the fine particles to be obtained. This indicates that the pressure of the water is insufficient to move the fine particles. Then the drains are driven further.

This process ensures formation of a sheath around the steel drain, composed of the coarser particles in the alluvium; this sheath itself forms a drain of large section of a reverse filter. During the course of desanding, the quantities of sand removed are measured carefully which enables one to estimate the diameter of the sheath thus formed around the drain.

## 28.0 **Drilling operation for radial slotted pipes.**

The nonreturn sand valve is to be first welded to the first joint and then welded to the bullet head.

The compressed air pipe with an air valve is then pushed through a plate fitted inside one end of the pipe through the sand valve into the bullet head. Two electrically operated jacks, carefully aligned in line and led into the stainless steel port hole are now operated to push the pipe, when about 600 mm of the pipe is still in the well a second pipe is welded. Another entire piece of compressed air pipe is

screwed on and jacks are realigned in the second pipe to push it. The bullet head punctures the timber plate previously fixed and 50 mm concrete cover and comes out into the aquifer. Now compressed air is forced into aquifer through big holes in the bullet head agitating the aquifer. As the air is switched off and the air valve is opened at the well end, the built-up pressure around the bullet head forces pipes in reverse in the compressed air pipe and they came out into well. A small push of 75 mm is again applied by the jacks and the process is repeated with compressed air until about 0.3 cm<sup>3</sup> of materials is removed with a push of 1 m or until the same stops coming into the well whichever is earlier.

The process serves two purpose (i) to facilitate pushing the pipes due to loosening of aquifer and a filter is created around the pipes for free flow of water through the loosen aquifer. As each piece of pipe is pushed another piece having next serial no. and of same length is welded to continue the process until a radial length of about 40 m. (slotted) + 10 m (blind) = 50 m is reached through each port hole.

In order to know the strata through which the radius passes, the contractor will have to make 4 test bores of 100 mm dia. around the periphery of the well and at a radial distance of 20 m.

The bore shall be drilled to the proposed depth of radials manually and not by machine. The materials extracted from the bores shall be collected at every meter depth and preserved in small plastic bags weighing approximate 2 (two) Kg. A slip of paper showing the number of the test bore and the depth at which the sample was gathered shall be placed in the bag.

The writing shall be in indelible ink. These bags with materials duly labelled shall be handed over to the EIC in 3 sets. The second one for the client and the third for the contractor. The cost of these four test bores shall be included in the rate of per meter of driving the stainless steel lateral and no separate payment will be made on this account. Payment for driving shall be made for exact length of pipe driven from inside the well to the front tip of the bullet head.

### **29. Fabricating, supplying and welding non-return sand valves in the front end of first slotted pipe:**

This one-way valve prevents sand coming through the big holes in the bullet head. The circular plate must be so welded at right angle to the slots of slotted pipes that the flap of the valve open towards the bullet head and when the compressed air pipe is withdrawn from the bullet head, the flap automatically close preventing sand from going further into the slotted pipe and then into the well. The flap must move freely around the pin and the whole assembly must be accurately fabricated as shown in the designed drawings submitted by the tenderer and approved by the EIC. The cost of this work including materials and labour shall be inclusive in his quoted rate under proper item in the schedule.

### **30.0 Supplying fitting 400 mm dia. sluice valves etc.**

These valves are fitted on the flange inside the well of the M.S. port holes for facility of closing or opening of any specific or all at a time whenever it is so required. They must conform to class — I of ISS 2906 of 1969 with double flanges with non-rising forged high tensile bronze spindle. They must have SI certification mark and shall be perfectly water tight, when closed under working condition. The rate will include stock head on operating platform and hand wheel, long connecting (extended spindle) rod connecting the head stock down to the sluice valve supplying fitting fixing of clamps, bushes and universal couplings etc. for smooth operation of the valve from an intermediate platform about 2.00 meter below the pump house floor. The cost of materials and labour should be included under proper item of the schedule. No separate payment shall be made.

### **31. Precast Deck slab on approach bridge in M20 concrete blocks:**

The blocks are precast on a suitable level platform and cured properly. Then the same are lifted and carried on the bridge and laid between the longitudinal floor channels to form the bridge deck. Two to three such blocks will be tested by placing them in position and putting sand bags over it to see that they are capable of taking 900 Kg / Cm<sup>2</sup> of stress on a span of 1600 mm.

The top surface of the blocks shall be kept rough to provide gripping with surface screeding.

The sides of the tapered as shown in the drawing approved.

### **32.0 25 mm hick surface screeding made of M20 (1: 1.5 :3)**

The surface screeding of M20 mix (1: 1.5 :3) shall be laid using graded aggregate less than 12 mm and laid uniformly on the top of the precast block as well as filling in the gaps along and at right angle to the tapered edges between adjoining blocks making uniform homogeneous deck. The top surface of the screening shall be made non-skid by pressing a wired fabric, curing shall be done by impounding with water for 7 days.

**33.0 Responsibility of level and alignment:**

The contractor shall be entirely and exclusively responsible for all levels and also the horizontal and vertical alignment of the levels and correctness of every part of the work and shall correct any error or imperfection therein. Such rectification shall be carried out by the contractor at his own cost when instructions are issued to that effect by the Engineer — in-Charge. The contractor shall be responsible for ensuring the correctness and accuracy of levels and dimensions of the foundation, orientation of foundation bolts etc. Any inaccuracy brought to the notice by the E-I-C or his representative shall be got rectified at contractor's risk and cost.

**34.0 Inspection:**

No materials shall be dispatched from the contractor's work before obtaining an inspection or certificate from the Engineer-in-charge (EIC).

The contractor is to provide at all times during the progress of the work and the maintenance period, proper means of access with ladders, gangways etc for safe movement of EIC for necessary inspection of works. The cost thereof shall be inclusive in his quoted rates.

**35.0 Tests:**

All tests considered necessary in connection with the execution of the work as directed by the Engineer-in-Charge shall be carried out at the owner's field laboratory or at any other approved laboratory. Cost of all such tests at such places are to be borne by the contractor.

**36.0 Time schedule of construction:**

In conformity with the period in the contract, the contractor shall prepare with care the details time required for the construction work unit / item wise for acceptance by the Engineer-in-charge before entering into the agreement of the work.

**37.0 The period of Liability and Guarantee.**

The contractor shall be liable for a period of five years after the date of issue of the certificate of completion of work issued by the Engineer-in-charge. The completion time shall be counted from the date of satisfactory trial run of the whole system for a period of 6 (three) months after completion of the electrical and Mechanical work and installations (not covered under this contract). This period shall be deemed as guarantee period during which the contractor shall be responsible for rectifying any defects that may be got rectified by the EIC at the risk and cost of the contractor and such cost shall be adjusted against the security deposit.

**38.0 Completion Documents:**

The following documents will be deemed to form the completion documents.

i) A general lay out and elevation (across the river) showing the position of collector well, well foundations

for piers, abutment, piers, supporting girder / truss, deck slab, railings, pump House with reference to bed level, H.F.L., free board maintained all in GTS datum actually carried out in execution.

ii)	<p>The set of construction drawings showing therein the modifications and corrections made during the course of execution signed by the Engineer-in-charge.</p> <p>Completion certificate for embedded and covered up works.</p> <p>Certificate of final levels as set out for various works.</p> <p>List of surplus materials returned to stores if any.</p> <p>All these documents bound in three separate sets as mentioned above shall be submitted to the Engineer-in-charge before issuance of completion certificate.</p>
iii) iv) v)	

**39.0 Water tightness and yield Test of collector well:**

The entire structure of the collector well composing of bottom plug cutting edge, subsurface RCC floor above bottom plug, steining wall laying below G.L. and well shaft laying above G.L. up to flooring of pump house shall be perfectly water tight and there shall be no leakage water coming into the well from any part when it is completely made empty. Any leakage or soakage in any part of the well has to be made water tight by cement grouting or any other method considered safe & sound by the



E.I.C at the risk and cost of the contractor. The water tightness shall be examined by keeping the well empty for continuous 10 days or as decided by the EIC. But such emptying the well shall not be done when there is flood outside the well in the river for safety even if the bottom plug and the RCC floor of the well, steining has to be designed to withstand the highest possible hydraulic pressure from outside and bottom.

After observing the water tightness test satisfactorily, the contractor has to give yield test of the collector well. The yield test is to be given by pumps only, at a depression of 4.0 mtr. The yield test of collector well will be measured over a 90° V — Notch, reading being taken every half an hour for a period of 8 hours. The measuring device has to be supplied by the contractor at his cost. All costs for giving the yield test and also the cost for supplying, fitting, fixing and removing all pipes, specials, valves etc. after the test is over should be included in the item of yield test and no extra claim will be entertained.

The yield from the each collector well should be at least 22.73 MLD (i.e, 1137 m<sup>3</sup>/hour considering 20 hours pumping per day) free from sand and at a draw down near about 4.0 m from the static water level. If the discharge falls below 22.73 MLD after using specified length and diameter of strainer, a deduction of Rs.50,000.00 per 25.0 m<sup>3</sup>/hour or part thereof, will be made up to a minimum discharge of 1.80 MGD (510.81 m<sup>3</sup>/hour) at a depression of about 4.0 mt. If the discharge is below 1.80 MGD, the collector well will be considered as partial successful and a deduction of 10% of all items related with collector well (excluding items related with bridge) will be made.

Cost of all these works shall be included in his quoted rates including cost of labour, carriage of materials, hire charge of machineries and tools and plants etc.

#### **40.0 Jacking Force:**

The jacks for applying horizontal force to push the radials strainers must be of adequate capacity to push each 400 mm internal dia. stainless steel slotted pipes through the aquifer to an average length of (40 + 10) = 50 meter and each one of not less than 150 tonne capacity.

#### **41.0 Terms and stages of payments:**

Subject to deduction of security deposit as per relevant clause of WBF 2912/2911 (i) / (ii), recovery of the cost Govt materials issued, income Tax, G.S.T and any specials security deposit if specified elsewhere in the tender specification or documents progressive payment may be made against the completed or partly completed items of work as decided by the EIC, such interim payments, however, shall not be construed to mean that the respective items / components have been finally approved and accepted by the Department and the contractor shall not be exempted from or relieved of his responsibility to set right at his cost any defects / deficiencies which may come to light subsequently.

#### **42.0 Phasing of payments:**

Interim payment of the value of work executed shall be done progressively on completion of each item / component as per break up schedule to be approved by the EIC after deduction of usual deduction of cost of departmental materials issued, income tax, G.S.T, security deposit as per provision in WBF 2912/ 2911 (i) / (ii) and any specials security deposit if deducted as per provision elsewhere. No claim for interest or compensation shall be entertained in respect to any money deducted as per conditions of contract or balance which may be due or alleged to be due to contractor owing to any dispute between the Department and the contractor or in respect to any delay in making payment of progressive or final bill to the contractor.

**43.0** Departure if any from the specification contained herein should be clearly mentioned and got approved shall be deemed to have violated the agreement conforming to the specifications given in the tender documents.

#### **44.0 Measurements:**

All the items of works, whether individually payable or not and whether from a part or whole of the lumpsum items, shall be measured and recorded in measurement books by the departmental staff. The

contractor shall give not less than five days' notice in writing to the Engineer-in-charge about the work which is proposed to be covered or placed beyond the reach of measurement. If any work is covered without such written notice, the same shall be uncovered at the cost of the contractor and in default there are no payments shall be made for such work.

#### 45.0 Time of completion:

The entire work shall be completed within the stipulated time of as mentioned in the tender notice. This time will be counted from the date of issuance of work order by the Executive Engineer. After the acceptance order is issued by the tender inviting authority, the selected contractor shall forthwith contact the Executive Engineer and furnish within 7 days necessary I.T. / G.S.T clearance certificates, and other certificates as necessary to enable him to issue agreement papers which should be resubmitted after signing at appropriate places and all pages and enclosures properly within 7 days of issuance of agreement forms. Thereafter on verifying the agreement and signed by respective officers at appropriate places, the work order will be issued. The contractor shall execute formal agreement in quadruplicate, which will be available from the office of the Engineer-in-charge at a price per set mentioned in tender notice. One copy of the tender agreement will be returned to the contractor duly signed by the competent authority of the Department. Acceptance order is liable to be cancelled with forfeiture of Earnest money in case of failure to contact the Executive Engineer for performing formal agreement within the time mentioned.

#### 46.0 Testing materials supplied by the contractor and work tests of 15 cm concrete cubes:

The materials to be supplied by the contractor shall have to be tested by any of the inspection and testing agencies at the cost of the contractor as follows:

- i) Director general of Inspection (Mechanical wing) Govt of India, Nizam palace, 2, M.S Building (8th floor), 234 / 4 A.J.C. Bose Road, Calcutta — 20
- ii) M/S Superintendence Co. of India (P) Ltd, 46 /C Chowrighi Road, Calcutta — 71.
- iii) S.G.S (India) Ltd., Calcutta. For works test of concrete cubes or any other test the testing may be done also at,
  - i) National Test House, Alipore,
  - ii) IIT, Kharagpur.
  - iii) National Institute of Technology, Durgapur. The result of the test reports shall be binding on the contractor.

#### 47.0 Floor of pump house:

The floor of the pump house will rest on R.C.C. beams and cross beams of adequate size and sections placed in such a manner as to withstand the vibration caused due to running of pumps. The flooring shall be partly done with R.C.C slab cast in situ with ironite / vitrified finish and partly with fabricated steel work in the areas of the pump bases and work shall be so done that the pumps can be conveniently installed and withdrawn whenever necessary. The composite flooring shall be so done that no leakage water falls into the well. There shall be adequate nos. of manholes for inspection and entering into the well or intermediate platform. Adequate nos. of vent pipes should also be provided at suitable locations above H.F.L. with their mouths upwards and the mouth being covered with perforated caps. The diameter of vent pipes shall not be less than 100 mm.

### **B) BRIEF SPECIFICATIONS FOR CONSTRUCTION OF BUILDING**

#### **EARTH WORK IN EXCAVATION.**

- |   |  |
|---|--|
| 1 | Foundation when excavated to the levels shown in the drawing would be shown to the EIC and if on |
|---|--|

account of bad soil or for any reason whatsoever he decides to go deeper with the foundation the contractor shall excavate further depth but, in such cases, the contractor should take written permission from the EIC. In no case shall the foundation soling or concrete be laid prior to receiving the orders to that effect from the EIC or his authorized representative.

#### **BRICK SOLING.**

- |   |   |
|---|---|
| 2 | The soling should be laid picked bricks in the English bond. The gaps between two bricks should be filled |
|---|---|

up by sand. The maximum gaps between the two bricks should not exceed 19mm. The bed should be perfectly leveled after the laying operation. The picked bricks should be uniform in size. Adequate water should be added during laying operation and sand should be well compacted. In case of floor soling, the earth inside should be well compacted with sufficient water. The floor soling should be laid only after the compaction of earth is approved by the EIC.

#### **CEMENT CONCRETE IN FOUNDATION.**

- |   |  |
|---|--|
| 3 | Sizes of stone chips should be limited to 25mm to 19mm. Care should be taken so that the dust is not |
|---|--|

added within the aggregate. Mixing should be done properly. In the 1st phase, the stone chips should be stacked neatly on a platform and the stack measured. Requisite quantity of sand and cement should be added at the top then water should be added. Mixing should be done by mechanical mixer machine or hand mixing may be allowed with addition of 10% extra cement & care should be taken such that the mixing has been done to the satisfaction of the EIC.

The concrete then slowly be applied on the foundation. The thickness of concrete shown in the item of work would be considered as finished thickness after compaction & bedding. The level should be maintained properly and the thickness should be uniform, curing should be done with water.

4	<b>1ST CLASS BRICK WORK IN FOUNDATION, PLINTH AND SUPER STRUCTURE.</b> Brick work should consist of 1st class bricks laid in English bond with mortar as specified in the item.
---	--

Costs involved for cutting of bricks as required are covered in the rates for relevant items of bricks works.

Brick walls shall always be carried out regularly in plane and true to lines and level as possible along their entire length. The set brick provision etc. shall be in strict conformity with the mortar joints should be of uniform thickness of 12mm. thick with such tolerance as may be considered reasonable by the EIC. All brick works shall be kept thoroughly wet for period of not less than 24 hours before being used in work. Care should be taken that each brick is thoroughly wet when it is laid.

No work should be carried out more than one scaffolding height of about 1.53mtrs above the adjoining walls. The surface of the wall should be kept clean by soft brush whilst the mortar is fresh. The scaffoldings should be strong enough to withstand weight of masons and the workers and for other working elements.

#### **5. CEMENT CONCRETE WORKS PLAIN OR REINFORCED.**

**Shuttering and staging:** Whenever necessary the staging must be provided unless otherwise stated. No payment should be made for such shuttering, staging and cost thereof would be deemed to have been covered by the rates for relevant finished item work. Where payments of shuttering have been specified, the rate should be deemed to cover the cost of necessary staging as well, payment if any for shuttering would be on the basis of surface area of shuttering in actual contact with concrete. Surface should be of approved dressed timber time to time, not less than 25mm. to 19mm thick, surface to be in contact with concrete are to be properly plain or smooth except where otherwise stated. As an alternative sufficiently rigid and strong shuttering of steel may be provided. In every case, the joints of shuttering are to be such as to prevent loss of liquid from concrete. In timber shuttering, the joints should therefore be either tongued and grooved or the joints must be perfectly close and lined with craft paper or other types of approved materials. In case of steel shuttering, also the joints are to be similarly lined. All shuttering and framing must be adequately stayed & braced to the satisfaction of EIC for properly supporting concrete during the period of hardening. It should be so constructed that it may be removed without shock or vibration to concrete.

(i) In normal weather and with ordinary cement, vertical or side shuttering may be removed after 24 hours and bottom shuttering of horizontal after 21 days from the date of placement of concrete in the structure. The above-mentioned period is minimum and may so extend up to discretion of EIC. No plugs, bolts, ties, bolt, brace or any other appliances whatsoever for the purpose of supporting the shuttering should not be placed in such position which may cause damage to the structure while removing.

(ii) Mixing, placing & compaction are the most important procedure for concreting. Absolute care should be taken in order to carrying such operations. For the purpose of each & every batch of concrete gauge boxes are to be used. For large concrete work, the cement and aggregates should be added by weight and for similar work by volume. In case of volumetric measurement, the weight of one bag of cement would be considered as 1 cft and corresponding volume 0.035 cum. Sufficient water should be added to obtain proper workability so that the mixture may flow readily round all the reinforcements and into every part of mould. The workability would be determined by the amount of slump. The slump test would have to be carried out with concrete immediately after it has been mixed and before any initial set, following slumps would have to be maintained if not otherwise stated.

a) For concrete not less than 1:2:4 2.5 cm.

b) For concrete liner than 1:2:4 3.8 cm.

The mixing operation should be done by a mechanical mixer & for small batches hand mixing may be allowed but, in that case, the contractor should be careful enough for mixing. The contractor shall prepare test moulds for testing as per Indian Standard specification. The contractor should produce test reports of concrete blocks, if required to be submitted by the department or the EIC at their own cost. The test report should satisfy the concrete strength as specified by ISS for testing of materials. Concrete should be handled from the place of mixing to the place of final deposition rapidly as

possible unless specified or permitted by EIC. Concrete should not be dropped freely from a height of more than 1.8m. During placing, concrete should be thoroughly compacted by mechanical vibrators as may be specified by EIC. Thickness shown in concrete should be considered as finished thickness after compaction.

(iii) Protection & curing: The contractor would protect freshly laid concrete from rapid drying due to strong sun shine, drying winds etc. Watering during curing period required for this purpose, should be continued daily including holidays. Joints are to be raked at least 12.5mm deep for pointing or plaster.

(iv) Construction joints: Proper construction joints should be provided whenever necessary. When the work has to be commenced on a surface which has hardened, such surface shall be well roughened and all laitance removed. The surface shall then be swept clean, thoroughly wetted and covered with a thin layer of mortar, composed of equal volumes of cement and sand. Such works shall be held to be covered by the rates for concrete.

6	<p><b>DAMP PROOF COURSE:</b> This should be done properly on walls at plinth level in proportion as specified in the item of work. It should be done continuously and surface should be double chequered. It should be properly cured by water for at least 3 days.</p>
7	<p><b>CEMENT PLASTER:</b> Cement plaster would be of various thickness &amp; only the average thickness is shown in schedule. The joints of brick work should be properly raked out. Faces of RCC slabs, lintels, beams, shall also be raked and properly cleaned. Irregular surfaces should be chiseled and plastering should be done true to plumb and should be protected from the heat of the sun. This plastering may be required to be done at any height or position and for this purpose, the contractor should erect necessary staging and scaffolding. Proper curing should be done by water and edges of opening, if so directed by the EIC shall be rounded off or chamfered with the same mortar without any additional item over the existing item rate. The proportions are shown in the item of schedule</p>

8	<p><b>STONE FLOORING:</b> The subgrade should be properly washed, cleaned and one coat of cement wash should be applied on the subgrade. The proportion of concrete is shown in the schedule. The sizes of stones should be perfectly maintained and all aggregates should be properly washed and cleaned. The mixing may be done either by mechanical mixer or hand batches. In case of hand mixing, additional cement limited to 10 (ten) per cent should be added. It should be laid in panels and sized should be maintained as directed by the EIC. Suitable grading should be provided. The thickness shown in the schedule is an average thickness after compaction. The top surface should be finished smooth by cement punning &amp; thickness should not be less than at least 1.36m</p>
---	--

## 9. CERAMIC TILES FLOORING / WALLING :

**9.1.1** The tile shall be of approved make and generally conform to I.S. 13755, IS 777, IS 388. The tile shall be of earthenware covered by a glaze thoroughly matured and fitted to the body. The tile shall be flat, sound, true to shape and free from blisters, crazing, chips, welts, crawling or other imperfections detracting from their appearance when viewed from a distance of 1 m.

**9.1.2** The tile shall be square or rectangular of nominal size such as 100 mm X 100 mm, 100 mm X 200 mm or as directed by the E.I.C. The thickness of the tiles shall be 5 mm or 6 mm as specified. The average length, breadth shall not vary more than + 0.5 mm. Tolerance in thickness shall be + 0.4 mm.

**9.1.3** The top surface of the tiles shall be glazed and glaze shall be either glossy or matt as specified. The underside of the tiles shall not have glaze on more than 5% of the area in order that the tile may adhere properly to the base. The edges of the tile shall be preferably glazed.

**9.1.4** Besides, the tile shall be resistant to chemical and average rate of absorption of water shall not exceed 20% when tested in accordance to I.S. 777, IS 388.

### 9.2 Preparation of surface of Wall & Laying on it:

**9.2.1** The joints shall be raked out to a depth of at least 15 mm in masonry walls. In case of concrete walls, the surface shall be hacked and roughened with wire brushes. The surface shall be cleaned thoroughly, washed with water and kept wet before walling/skirting is commenced.

**9.2.3** 12 mm thick plaster of cement mortar 1:3 (1 cement: 3 coarse sand) mix or as specified shall be applied and allowed to harden. The plaster shall be roughened with wire brushes or by scratching diagonal at closed intervals.

**9.2.4** The marble chips, 3 mm to 4 mm size, shall be fixed on the back side of the tiles adopting the

same procedure as mentioned earlier to help increase the bonding. The tiles fixed with marble chips should be soaked in water thoroughly for few hours, washed clean and coat of cement slurry shall be applied liberally at the back of tiles and set in the bedding mortar. The tiles shall be tamped and corrected to proper plane and lines. The tiles shall be set in the required pattern and jointed. The joint shall be as fine as possible. Top of skirting/wall shall be truly horizontal and joints truly vertical except where otherwise indicated. Skirting shall rest on the top of the flooring. Where full size tiles cannot be fixed there shall be cut (sawn) to the required size and their edges rubbed smooth.

<b>1</b>	<p><b>R.C.C. JALI WORK:</b> The work should be done as per drawing. The stone chips should be 6mm size and the proportion of concrete has been shown in the schedule. The circles of sharp edges should be perfectly done and G.I. wires should be used as reinforcement. The casting may be done in the one operations and placed as directed by the EIC. The whole structure should be immersed in water for curing for at least for 7 days. The surface should be plastered with neat cement. The line levels should be perfect and should be fixed in proper position. The item rate includes all costs of labours, materials and fixing complete</p>
----------	---

<b>1</b>	<p><b>WOOD WORKS:</b> Timber should be of first class variety, seasoned, free from knots and large cracks. In case of teak, no crack wood should be used.</p>
----------	---

**a) Sal wood works in frames of door & windows:** Frames should be properly manufactured and the sides should be smooth. The joints are to be perfect and, in all cases, right angles must be maintained.

The cross section should be uniform throughout. The rivet should be cut 3.8cm x 1.25cm depending on the thickness of shutter. In every case, the section given in the schedule is the finished thickness after planing. For the purpose of measurement only, the total cubic content would be considered excluding rivet out. The frames are to be properly fixed in position and true to plumb. Before fixing the frame on the wall, a coat of anti-corrosive paint should be applied to act as a preventive against white ants. The item rate includes such cost for fixing operation. The door should be placed in position and the hole fast should be grouted by concrete (1:2:4) with 19mm down stone chips in each clamp approximate 15x15x25cm = 0.0056 cum.

**b) M.S. Hold Fast:** The sizes of a hold fast for door & windows should be 225x19x6.25mm and should be properly fixed in position by 3.8cm size steel screws. Ends preferably be bifurcated. Item rate includes all costs of supply of labour, materials.

**c) Door & window shutters:** The thickness of the door & window shutter should be taken that the thickness shown in schedule in the finished thickness after painting. The panel wood should be well seasoned. The design of panel shutter will be strictly as per drawing. The EIC may slightly alter the drawing but in that case the item rate shall not deviate. The work should be of first class workmanship.

**d) Iron butt hinges:** Iron butt hinges should be of best quality and of approved make. It should be prepared from sheet steel having 1st class workmanship and painted with anticorrosive paints. The contractor should first get the materials approved by the EIC. The work comprises of supplying materials and cutting grooves on the frame and shutter so as to fix the hinges with 6 nos. of steel screws. The sizes of hinges are given in the item of schedule normal size 10cm long x 6.5cm x 2.642mm.

**e) Buffer blocks:** Buffer blocks should be best quality and of 1st class workmanship made of seasoned

Sal wood timber free from knots and sap or top wood. The sizes would be 15 x 6.5 x 10cm or as may be directed by the EIC. The same should be properly fitted and fixed in position by 2 nos. suitable steel screws.

**f) Hinge cleat:** Hinge cleat should be prepared from best quality Sal wood, free from knots and top wood. The sizes will be 10 x 3.8 x 3.8cm or as may be directed by the EIC. One steel butt hinges should be fitted, fixed in position with necessary steel screws. The quality of butt hinges would conform to the above specification. 10(d). The work includes the cost of materials & fitting, fixing complete in position as directed & painting 2 coats of approved paint of approved quality & make complete. Normal size – 5cm. X 3.8cm. x 3.5mm.

**g) M.S. oxidised socket bolts:** The materials should be of approved quality & make. The materials should be manufactured from 1st class M.S. round bar of 19/12.5 bolt dia. and sockets from M.S. flat/ plates. The plate should be at least 0.78cm thick and 1 inch in width. The EIC reserves the full right to

make little deviation for the above dimension. The length of each bolt has been given in the schedule of item. The surface should be properly oxidized. The contractor should first produce sample of the materials and if so approved, then the materials should be fitted, fixed in position by necessary steel screws. The item includes all costs of supplying the materials fitting & fixing complete.

**h) M.S. oxidised hasp bolt:** The materials should be best quality and approved type. The materials should be manufactured from sheet metal and mild steel rounds. Necessary nuts & bolts be associated with the hasp bolt. The surface should be properly oxidized and fitting of the hasp bolt should be done such a way that the operation can be done with ease. Care should be taken while fixing that the door shutter is not damaged. The back side of the bolt should be properly sealed so that the bolt cannot be removed easily. The item includes all costs of supplying materials and fitting complete in proper position as directed.

**i) Sal wood Sashes bars:** Sal wood should be best quality, free from knot and cracks, well-seasoned and hard. The work comprises of the following item; supplying 5cm X 4.78cm section and approximately 1m length Sal wood straight bar one and properly rounded and fixed with the door frame with 19mm dia. bolts approximately 10cm in length including washers.

The Sal wood bar will rest on 17' holder, which should be manufactured from M.S. flats, and properly fitted on the other side of the frame with iron screws (at least: 2 nos.) to hold the cross bar. The section of the holder should not be less than 2.5cm x 1.5cm. The item includes all costs of supplying materials & fitting, fixing complete in proper position and painted 2 coats with approved paint.

#### **Steel Window:**

The frames and sashes of steel window, ventilators, sky light both fixed and moveable type are to be made from hot rolled steel sections conforming to relevant I.S. The tolerance in thickness of section shall be + 0.2 mm. The steel windows/ventilators and composite unit shall be got fabricated in the work-shop approved by E.I.C. The windows/ventilators shall strictly be according to the specified sizes and design. The actual size of windows/ventilators shall not vary by more than + 1.5 mm. from those giving in the drawing. The corner of frame shall be welded to form a solid fused welded joint and the processes of welding shall be flash butt welding, the section for glazing shall be turned and riveted in the frames. The welds should be made all along the place of meeting the members and tack welding should not be permitted. Weld should be properly grounded and complete cross section of the corner shall be thoroughly checked up, so that no cavities are visible. For fixing steel hinges in "side hung windows" slots shall be cut in the fixed frame and hinges inserted inside and welded to the frame at the back. The hinges shall be of projecting type, non-projecting type hinges may be allowed if approved by E.I.C. The hinge pin and washer shall be of galvanized steel or aluminum alloy of suitable thickness. The handle of side hung shutter shall be of pressed brass, cast brass, aluminum or steel protecting against rusting and shall be mounted on a steel plate. The handle plate shall be welded, screwed, and/or riveted to the opening frame in such a manner that it should be fixed before the shutter is glazed.

The handle shall have a two-point nose which shall engage with a brass or a aluminum alloy striking plate on the fixed frame in a slightly open position as well as close position. The boss of handle shall incorporate as friction device to prevent the handle from dropping under its own weight. In case of no friction type hinges are provided, the windows shall be fitted with peg-stays which shall be either black oxidized steel, pressed or cast brass, or as specified, 400 mm long with steel peg and locking brackets. The peg stay shall have three holes to open the side-hung casement in three different angles. Side hung shutter fitted with friction hinges shall not be provided with a peg stay.

#### **Aluminum Window:**

All the windows are to be made of Aluminum unless otherwise specified or approved by the EIC. The frames and sashes of Aluminum window, ventilators, and skylight both fixed and moveable type is to be made from Aluminum sections conforming to relevant I.S. The tolerance in thickness of section shall be + 0.2 mm. The Aluminum windows/ventilators and composite unit shall be got fabricated in the workshop approved by E.I.C. The windows/ventilators shall strictly be according to the specified sizes and design. The actual size of windows/ventilators shall not vary by more than + 1.5 mm. from those giving in the drawing. The corner of frame shall be welded to form a solid fused welded joint and the processes of welding shall be flash butt welding, the section for glazing shall be turned and riveted in the frames. The welds should be made all along the place of meeting the members and tack welding should not be permitted. Weld should be properly grounded and complete cross section of the corner shall be thoroughly checked up, so that no cavities are visible. For fixing steel hinges in "side hung windows" slots shall be cut in the fixed frame and hinges inserted inside and welded to the frame at the back. The hinges shall be of projecting type, non-projecting type hinges may be allowed if approved by E.I.C. The hinge pin and washer shall be of galvanized steel or aluminum alloy of suitable thickness. The handle of side hung shutter shall be of pressed brass, cast brass, aluminum or steel

protecting against rusting and shall be mounted on a steel plate. The handle plate shall be welded, screwed, and/or riveted to the opening frame in such a manner that it should be fixed before the shutter is glazed. The handle shall have a two-point nose, which shall engage with a brass or an aluminum alloy striking plate on the fixed frame in a slightly open position as well as close position. The boss of handle shall incorporate as friction device to prevent the handle from dropping under its own weight. In case of no friction type hinges are provided, the windows shall be fitted with peg-stays which shall be either black oxidized steel, pressed or cast brass, or as specified, 400 mm long with steel peg and locking brackets. The peg stay shall have three holes to open the side-hung casement in three different angles. Side hung shutter fitted with friction hinges shall not be provided with a peg stay.

**12. WHITE WASHING, COLOUR WASHING & PAINTING**

All surfaces for white washing, colour washing or painting shall be properly cleaned and prepared to the satisfaction of the EIC before application of the treatment.

**a) White Washing:** The white washing is to be done with 5 parts of stone lime and one part of slaked lime with necessary gum (about 2 Kg to 1 cum of lime) and to be mixed as per standard practice for the purpose of applying white washing, necessary scaffolding should have to be erected. The item includes all costs of supplying labour, materials, scaffolding etc., complete. The application of the wash should be done by new jute brushes. Each coat of white wash shall be done separately allowing drying before the next coat is laid on.

**b) Colour Washing:** The colour wash should have a priming as per specification of the colour wash manufacturer. The colour wash should be first approved by the EIC.

**c) Painting:** All surfaces of the wood work or the steel surface where the paint shall be applied, should be properly cleaned by sand paper. Where necessary good quality putty may be used to hide all holes, breaks, open joints etc. The rate of painting includes such works and Shalimar wood/steel primer and paint, Jonson Nicolson wood coat paint or steel coat paints. Paint should be applied to clean surface with approved brushes and surface needs to be sand papered. After every drying coat, all works when completed should present a smooth clean, solid and uniform surface to satisfaction of the EIC. The colour and shade of the paint should be approved by the EIC.

<p>1 3.</p>	<p><b>WASHABLE DISTEMPER: -</b> All inside plastered surfaces of buildings &amp; other structures shall be painted with washable Distemper as per manufacturer's specifications unless otherwise specified or directed by the EIC to approved shade and colour.</p>
<p>1 4.</p>	<p><b>OUTSIDE PAINTING BY WEATHER COAT:</b> All outside surfaces of buildings &amp; other structures shall be painted with damp proof weather coats as per manufacturer's specifications unless otherwise specified or directed by the EIC to approved shade and colour. Where specified, external surface shall be finished with 2 coats of "Weather Coat" or similar decorative colour finish of approved colour, shade &amp; manufacture. The surface is to be previously cleaned down to remove loose dust or dirt by use of stiff wire brush. All inequalities to be rubbed down and defects rectified. The surface to be wetted well with water and the surface water is to be allowed to run off. The "Weather Coat" or equivalent to be mixed will be strictly as per manufacturer's specification</p>
<p>1 5.</p>	<p><b>M.S. WORKS IN LINTELS, BEAMS, AND SLABS ETC.:</b> M.S. rods of different sections will be issued to the contractor at a rate shown against item 8 above in general specification. The tendered rate includes all costs of taking delivery of materials from the departmental stores, carting and safe custody including hooking, cranking bending, binding &amp; supplying of 16 SW GI binding wires for concrete reinforcements. Excess rods in cut pieces within the tolerance limit will not be taken back from the contractor's custody after complete of the work unless those are in full straights. Item includes all costs of supplying labour and materials complete.</p>

**16. EARTH FILLING IN FOUNDATION & PLINTH:**

Contractor should bring earth from his own arrangement and properly fill the foundation and the plinth as per direction in 15cm. Layers. The earth should have to be properly consolidated with adequate water and rammed by iron rammers. For the purpose of payment, 1/3rd volume of excavation of under item-1 of the schedule will be accepted for filling trenches of the foundation plus the measurement of the consolidated earth in the plinth to be taken.

<p>1 7.</p>	<p><b>COLLAPSIBLE GATE:</b> This shall be of approved design conforming to ISI standard including all the costs of supplying &amp; fitting, fixing. Two coats of steel coat paint of approved quality &amp; shade should be applied. The rate should include all items stated above for the purpose of payment clear</p>
-----------------	--

	opening between the wall will be considered with the actual height of the gate.
1 8.	<b>ROLLING SHUTTER:</b> The shutter should be good standard and must be approved before use and should conform to manufacturers specification. It should be fitted and fixed in position by suitable fixing arrangements set in cement concrete including cutting necessary hole, chiseling etc.  in all, floor etc., and making good all damages. The shutter should be painted with 2 coats of steel coat paint approved quality and shade. The rate should include all the items stated above.
1 9.	<b>GRILLS:</b> All windows ventilators and railings where specified, shall be provided with suitable M.S. grills of approved design. The clear openings between two bars shall not exceed 100mm. The entire grill work including fitting, fixing shall have to be done as per specification laid down in P.W.D. Schedule.  The grill shall have to be provided with 2 coats of paints of approved make and shade over one coat of priming. The grill may also be used in some doors. The M.S. flats to be used for grill shall not be less than 20 mm X 4 mm is size. The weight of the grill shall be within 18kg/sq.m. to 20 kg/sq.m.

**19. GLAZED FAN-LIGHT SHUTTER:** The glass should be frosted one as per standard specification.

**20. GLASS WORK BEHIND JALLY WALLS:** The glass should be of approved fitted and fixed in position as per direction of the EIC.

2 1.	UPVC rainwater pipes shall conform to IS:13502-1992 and shall be installed as per approved position.
---------	--

Rainwater pipes fixed to the external walls and shall be blocked out at least 25mm from the plastered surface by means of cast iron bobbins. The rain-water pipes at the roof level shall be fitted with UPVC Roof outlet bend or a UPVC bend with a masonry bell mouth of suitable size fitted with a cast iron grating. The bottom of the down pipe shall be fitted with a shoe fixed 150mm above ground/apron level of the building as shown on the drawings. The sockets and spigots of pipes and fitting shall be jointed using cement mortar (1:2). UPVC rainwater pipes embedded in concrete or masonry and shall be securely fixed to wall with wooden plugs and nails. Joints of the sockets and spigots of pipes and fittings shall be with cement mortar (1:2).

### C) SPECIFICATION FOR LAYING RISING MAIN

1.0 The work is to be carried out strictly in accordance with the drawings and specifications supplemented by other detailed working drawing and instructions as the Engineer-in-charge may order in writing from time to time except with prior written approval of the Engineer-in-charge.

2. 0 2. 1	<b>ISSUE OF DEPARTMENTAL MATERIALS</b> The Department will supply D.I (K-9 / K-7) pipes required for the work free of cost. Specials & Valves shall be supplied by the contractor. The agency have to lift the department materials from the Store against
--------------------	--

The delivery Order issued by the concerned Executive Engineer. Carriage /transportation charges including loading, unloading storage shall be included in the relevant item of work. Departmental materials will be issued to the contractor in such installments as will be deemed necessary by the Engineer-in-charge or his authorized representative. The contractor should check the materials at the time of issue and must be sure that the materials supplied are free from any crack, damage or any other imperfection. Contractors shall remain responsible for the safe custody of all kind of departmental materials issued to him till consumption thereof in the work and returned of surplus materials if any, to the local departmental store within scheme area /Head Works site. The materials must be stored at sites of work and must not be removed without specific permission of the Engineer-in-charge. Temporary store shall be built up by the contractor at suitable location and will be removed by the contractor at his own cost after the work is completed. All incidental charges incurred at the time of delivery of the materials from the local departmental stores till ultimate utilization in the work and returned of surplus material to the departmental local stores shall be borne by the contractor and no extra payment on this account would be made. The contractor shall have to satisfy the Engineer-in-charge with an account of the materials consumed in work and balance returned to the department, if any, of the departmental materials.

**2.2** For the departmental materials issued to the contractor, a stock register shall be maintained by the contractor and the day to day receipt, issue and balance of such materials shall be recorded therein. This register shall be produced by the contractor to the Engineer-in-charge or his representative whenever required for verification of stock. The Engineer-in-charge or his authorized representative



shall have free access to the godown of the contractor at any time without any prior intimation and to physically verify the stock.

2.3	<p>Materials supplied for a particular work or part thereof shall not be used or removed elsewhere except with the written permission of the Engineer-in-charge. The contractor shall be held responsible for any misuse, loss or damage for the Govt. materials while in his custody. The costs of such materials misused, lost or damaged shall be recovered from the contractor according to the provisions made in clause 2.6 herein after. 2.5 In the following cases the materials issued or handed over to the contractor shall be deemed to have been misused by him.</p>
2.4	<p>i) Materials lost or damaged due to negligence on the part of the contractor and / or defective storage by him and / or careless handling and use by him  ii) Materials used in excess of the requirements as shown in consumption chart in P.W.D. Schedule / MEDD te. Schedule.  iii) Materials used without permission of the Engineer-in-charge in temporary works (e.g., coffer dams, embankments, shoring etc.) in the construction of contractor's godown, site office, labour hutment etc. or in any other work beyond the scope of this contract.  2.6 The value of the materials (except cement, M.S. Rod and lead) misused, lost, damaged (in which case the decision of the Engineer-in-charge shall be final) shall be recovered @ 50% in excess of highest of the following three rates.  i) Issue rate as specified in the contract.  ii) Departmental stock rate at the time of recovery of cost.  iii) Market rate at the time of recovery of cost</p>

2.5	<p><b>OUTLINE OF WORK:</b>  The works of the contract includes Carriage of pipes and all other departmental materials required to be used for the above works from the local departmental store within scheme area / Head works site to the different places where they are to be used or utilized. Supply of all types of D.I Specials and C.I valves required for the work.</p>
-----	---

3.0	<p>Laying of pipes on M.S Access Bridge including handling, fitting, fixing, jointing pipes, specials &amp; valves in a prefixed or indicated alignment as per drawing and instruction of the Engineer-in-charge. Demonstrating hydraulic test of the pipe lines in suitable sections as per specification. Construction of valve chambers, thrust block and anchor blocks (as per type drawing). Executing all other works as have been set forth in the scope of work, schedule of quantities and / or in the drawing together with all other additional extra and varied works which may be ordered thereafter in connection with works.  Washing, cleaning and disinfecting the pipe lines as per specifications. Supplying transport, all labours and materials (except those to be supplied departmentally), tools and appliances required for executing works mentioned above. Maintaining all the works executed under this contract for a period as specified in relevant clause of B.F.2912 and as per specification.</p>
-----	---

4.01	<p><b>CARRIAGE OF MATERIALS</b>  The departmental D.I (K-9 / K-7) pipes will be made over to the contractor in lots or in part, as may be decided by the Engineer-in-charge or his representative, as well as depending on the availability of the materials, from Municipal Departmental Local store within scheme area / Head Works Site from time to time against</p>
------	--

clear hand receipt from their authorized representative. The quantity and time of each supply will be decided by the Engineer-in-charge.

4.2. The contractor shall solely remain responsible for the safe custody of those supplies, onwards from the date of issue till the same are used in the works, according to contract and the surplus ones are finally handed over including handing over of the works to this Directorate. Any loss or damage occurring during this period will have to be made good by the contractor at his own cost at the rate mentioned previously in sub-clause 2.6 herein above.

4.3. The cost of carriage charges have to be included in the Lump Sum rate.

4.4. No claim for extra payment due to any delay or detention, dispute, non-procurement of materials

(to be supplied departmentally) or for any other reasons will be entertained.

4.5. While receiving the departmental materials, the contractors shall verify and be satisfied about the actual quantity and quality of materials. Any complaint afterwards will be rejected.

5.0	<p><b>LAYING OF PIPES, SPECIALS, VALVES</b> It also includes carriage, storages, handling of pipes, specials, valves etc. lowering and laying of pipes and specials etc. in the trench carefully. The crane should be used for providing &amp; laying in alignment above 400 mm. dia. pipe. The rate includes the cost for construction of thrust block for the purpose of anchorage of C.I. /DI/MS Pipes, specials and valves etc.</p>
5.1	<p>Laying of pipes shall strictly be executed as specified in I.S.6530 of 1972 / I.S.3114 of 1994 / I.S:12288-1987 / I.S:7634 (Part-I to III) -1975/2012/2003 of as applicable jointly or separately unless otherwise specified hereinafter. Cutting the pipes to required sizes, if necessary, aligning them on bridge including laying, fitting &amp; fixings shall be done as necessary. Removal of the surplus materials has to be done by the contractor after completion of the work up to the satisfaction of the Engineer-in-charge. The scheduled rates for providing &amp; laying pipes are inclusive of the cost of the works of removal of surplus materials and cleaning site.</p>
6.0	<p><b>TESTING OF PIPE LINES</b> Testing of pipe line, joints and incidentally of the pipes, specials and valves shall be done by the contractors as per following conditions and according to the direction of Engineer-in-charge.</p>

6.1. Hydraulic pressure test of pipe lines shall be demonstrated by the contractor while the works of laying proceed in section of 500.0m and to stand a water pressure head of 61 m in case of cast iron & DI pipes for a continuous period of one hour. Pipe line testing reports month wise and section wise are to be submitted to the Executive Engineer at the end of each month.

6.2. For the purpose of demonstrating the hydraulic pressure test, the contractors must provide all necessary appliances tools and plants, specials, labourers etc. Further the contractors will arrange to procure water to perform the test if necessary. If necessary the contractors will have to sink small dia.(40mm.) tube well to procure water for testing. No extra payment will be made, for the procurement of water.

6.3. In a non-tube well area, if it is evident to the Engineer-in-charge that water for testing cannot be procured for reasons of water scarcity then the testing of different sections of the pipe line may be deferred up to a maximum period when water from the new sources is available near the pipe lines. In that case the contractors must arrange to isolate, at their cost pipe sections [length of each section should not exceed 1000 m] for the purpose of demonstrating the hydraulic test.

6.4. When departmental water is utilized for affecting the hydraulic test the contractors will pay at the rate Rs.2.50 (Three) only per hundred liters of water taken or the Municipal rate in force whichever is higher.

6.5. If the hydraulic test is deferred, an amount of payment against certain executed items shall be held up till successful performance of such test as laid down in Tender Document.

## 7.0 DISINFECTION

7.1. After completion of the pipe line works, all the lines shall be thoroughly washed with clear water as per direction in writing of the Engineer-in-charge. Water shall be supplied free of cost to the contractor for this purpose if the source is constructed by that time. All T & P for tapping the water source will be provided by him at his own cost.

7.2. The cleaned lines shall then be disinfected with chlorinated water containing a dose of chlorine (Bleaching Powder will be supplied by the contractor as may be directed by the E.I.C. or his representative. The chlorinated water must be kept within the pipe lines for 24 hours.

7.3. After proper disinfection, the pipe lines should be rewashed thoroughly with clear water including checking the entire distribution system with pressure gauge and rectifying defects including chokage, leakage etc. if any at contractors own cost up to the entire satisfaction of the Engineer-in-charge. The

contractors will bear the cost of fitting of the pressure gauge and necessary labour and materials including supply of pressure gauge etc.

7.4. No extra payment will be made for the works and measures mentioned in clauses 7.1 to 7.3 above

accepting specifically mentioned in the schedule of quantities.

#### **8.0 VALVE CHAMBER**

8.1. The sluice valve/wash out valve/air valve chambers will have to be constructed in accordance with the departmental type drawing at relevant items of the schedule of quantities and as per the direction of the Engineer-in-charge.

8.2. The positions of valve chambers have been shown, as far as possible, in the drawing. However, the pinpointed sites and number may be changed widely for which no claim or compensation shall be entertained. It will be the responsibility of the contractors to obtain from Engineer-in-charge in writing, the final list and locations of all such chambers.

8.3. The rates for construction of valve chambers are inclusive of all relevant items of works to be involved.

#### **9.0 JOINTS**

9.1. For lead joints the contractor will supply requisite quantities of yarn of approved quality, labour, Tools & fuels etc. required to complete all such joints for which payments will be made only as per relevant item of the schedule of quantities. The rate of lead joints in the schedule includes the cost of lead among others.

9.2. For flange joints the contractor will have to supply bolts, nuts, (Tata brand or equivalent in quality), washers, rubber insertions (each material shall conform relevant I.S. specification), white zinc etc. of approved quality including supply of labor, tools & plants to complete the joints in all respects satisfactorily for which payment will only be made as per relevant item in the schedule of quantities.

9.3. For tyton joints the jointing materials will be supplied departmentally free of cost

10.00 . The Cement for Project should be of as per related IS code of Premium Brand of Make ACC, Ultratech, Lafarge Concrete etc and it should be approved by the EIC.

**The Chairman/ Administrator**

**Burdwan Municipality**

### **SECTION - I**

#### **GENERAL CONDITION OF CONTRACT**

##### **GENERAL CONDITIONS OF CONTRACT**

01. Definitions and Interpretations

02. Duties of Engineer-in-Charge and his Representative

03. Responsibility and Power of Engineer-in-Charge and his Representative

04. Custody of Drawings

05. Contractor's General Obligations and Responsibility

06. Program of Work

07. Contractor's Superintendence

8. Contractor to arrange all Labour, Materials & Tools & Plants
9. Site Order Book
10. Delay in Getting Site of Work
11. Survey – Layout and Access
12. Arrangement of Land
13. Site Godown
14. Supply of Departmental Materials
15. Watching , Guarding and Lighting
16. Discrepancies
17. Materials to be supplied by Contractor
18. Workmen's Compensation
19. Hours of Work : Night Work
20. Contractor's Employees
21. Safety Measures and Public Convenience
22. Loss and Damage
23. Supervision of Work
24. Department's Right to Terminate Contract
25. Occupying Prior to Completion
26. Supplementary Specification
27. Clearance of Site on Completion
28. Land for Contractor's Establishment
29. First-Aid Facilities
30. Fire Fighting Arrangement
31. Department's Right to Split Package
32. Construction Records
33. Test for Water Tightness of Reservoir, Pipes, Valves etc.
34. Satisfactory Completion of Various Items
35. Reports & Returns
36. Terms & Stages of Payment
37. Insurance of Works etc.
38. Damage to Persons and Property
39. Accident or Injury to Workmen
40. Insurance Against Accident etc. to Workmen
41. Notification to Insurer
42. All Insurance at Contractor's Cost
43. Remedy on Contractor's Failure to Insure
44. Initial Security Deposit, Security Deposit, Performance Guarantee
45. Inspection Facilities
46. Testing & Testing Equipment
47. Idle Labour
48. Labour Act
49. Local Employment
50. Import License and Imported Equipments
51. Water Supply, Sanitation & Power
52. Storage and Safety of Equipments
53. Language for Correspondences
54. Contractor's Local Address
55. Recoveries
56. Reduced Rates
57. Minimum Wage Act
58. Precedence of Contract Documents
59. Time of Completion
60. Action for Non-Compliance
61. Progress Photographs
62. Deduction of Tax
63. I.E. Act
64. Typographical Error
65. Completion Certificate
66. Disinfection
67. Safety Requirements

## **GENERAL CONDITIONS OF CONTRACT**

The following words and expressions used in this Section as also in the other Sections of these bid documents shall, unless there is anything repugnant in the subject or context have the meaning hereby assigned to them except where the contract otherwise refers.

i) The **Government** means the Government of West Bengal.

ii)	<b>Department</b> means the Municipal Engineering Directorate Government of West Bengal.
-----	--

iii)	<b>Chief Engineer, Superintending Engineer, Executive Engineer &amp; Assistant Engineer</b> mean Engineer Officers of the M.E.Dte. Designated as such.
------	--

iv)	<b>Contractor/Bidder</b> means the persons or persons, firm or company whose bid has been accepted and who have entered into the contract for the performance of the work.
-----	--

v) **Contract/Bid Price** means the sum as stated in the letter of acceptance subject to such additions thereto or deductions there from as may be made under the provisions of the contract documents.

vi) **Engineer-in-Charge** (E.I.C.) means the concerned Executive Engineer, respective Civil Divn for civil and Executive Engineer of respective Mechanical/Electrical Divn. for Electrical and Mechanical works.

vii) **Drawings** means the drawings referred to in the bid documents and any modification of such drawings approved in writing by the Superintending Engineer or his representatives and such other drawing as may from time to time be furnished or approved in writing by the Superintending Engineer or his representative.

viii) **Approved** means approved in writing including subsequent written confirmation of any previous verbal approval and approval means notional approval in writing including as aforesaid.

ix) **Employer** means M.E.. Dte./Deptt. Govt. of West Bengal.

x) **Site** means the land and other places envisaged by the Government where work or works to be executed and carried out and also to be used for working space.

xi)	<b>Ground Level</b> means the level of the referred point of exposed surface of the ground as indicated in the drawing.
-----	---

xii) **Holiday** means a public holiday for the purpose of section 25 of the Negotiable Instrument Act 1881 or such other day on which the office remains closed for the day.

xiii) **Month** means English Calendar month.

xiv) **Specification** means specifications referred to in the bid and any modification thereof or addition thereto as may from time to time be furnished or approved in writing by the Superintending Engineer.

xv) **Store** means such storage areas including departmental Godown, stack yard etc. maintained by the M.E. Department.

xvi) **Work** means all of the works called for or shown in the bid documents, including preparation, construction, improvement and cleaning of sites including removing of debris etc. and maintained in accordance with the contract.

xvii) **Tests** mean such tests as are prescribed by the specifications or considered necessary by the Engineer-in-Charge.

xviii) **Cost** – The work **cost** shall be deemed to include overhead cost whether on or off the site and statutory taxes as applicable.

### **2. Duties of Engineer-in-Charge and His Representatives**

The Representative of Engineer-in-Charge shall be responsible to the Engineer-in-Charge and his duties are to watch and supervise the works and to test and examine any materials to be used or workmanship employed in connection with the works. He shall have no authority to relieve the contractor of any of his duties or obligations under the contract, nor to order any work involving delay or any extra payment by the Employer, not to make any variation of or in the works.

### **3. Responsibility and Power of Engineer-in-Charge and His Representative**

The Engineer-in-Charge or his representative shall watch and supervise the work. He shall have authority to stop the work whenever such stoppage may be necessary to ensure proper execution of the contract. He shall have authority to reject any work or materials which do not conform to the contract documents, to direct the application of forces to such portion of the work as in his judgment is required, to order the labour force increased or diminished, to direct the sequence of the work and to decide all questions which arise in the execution of the work. The Engineer-in-Charge

or his representative shall have the power of inspection of all work to be performed under this contract. All work shall be performed only in the presence of the Engineer-in-Charge or his representative. In order that inspection services may be provided, the contractor shall keep the Engineer-in-Charge or his representative posted concerning his operation plans at least one working day in advance. All work under or in course of execution or executed in pursuance of the contract shall at all times be open to the inspection and supervision of the Department and its representatives. The contractor shall at all times during the usual working hours, and at all other times at which reasonable notice of the intention of the Engineer-in-Charge or his representative to visit the works shall have been given to the contractor, either himself be present to receive orders and instructions or have responsible agent duly accredited in writing present for that purpose.

#### **4. Custody of Drawings**

Detailed working drawings shall be prepared and submitted by the successful Bidder after issuance of work order and before taking up the execution of work unless otherwise mentioned in the Tender Document. Departmental Drawings for the components which will be executed as per department drawing will be issued to the successful bidder. All the approved Drawings shall remain in the sole custody of the Engineer-in-Charge but two copies thereof shall be furnished to the Contractor free of charge. The Contractor shall provide and make at his own expenses any further copies required by him. At the completion of Contract the Contractor shall return to the Engineer-in-Charge all drawings provided under the Contract.

One copy of the Drawings, furnished to the Contractor as aforesaid, shall be kept by the Contractor on the site and the same shall at all reasonable times be available for inspection and use by the Engineer-in-Charge and his Representatives and by any other person authorized by the Engineer-in-Charge.

#### **5. Contractor's General Obligations and Responsibility**

The Contractor shall, subject to the provision of the contract, and with due care and diligence, execute and maintain the works and provide all labour, including the supervision thereof, materials, constructional Plant and all other things, whether of a temporary or permanent nature, required in and for such execution and maintenance, so far as the necessity for providing the same is specified in or is reasonably to be inferred from the contract.

#### **6. Programme of Work**

The Contractor shall furnish within a fortnight from the date of order to start the work, a progress schedule indicating a fortnightly periodical target of progress expected to be achieved indicating dates of completion of each major item of the work, also indicating the dates of arrival of major equipments required for completion of the work as per contract and also indicating intermediate progress at various stages of work within the total period of completion. The Schedule should aim and include practicable achievement towards completion of the whole work in the stipulated time and of proportionate completion of work on due dates. In case it is subsequently found necessary to alter the schedule, the Contractor shall submit in specified time a revised schedule for approval of the Engineer-in-Charge. The progress schedule shall be in the form of C.P.M Chart. The contractor shall also furnish the methodology to be adopted for execution of the individual item of work so as to ensure completion of the work within the target date of completion indicated elsewhere in this document. The submission to and approval by the Engineer-in-Charge or his Representative of such Programme or the furnishing of such particulars shall not relieve the contractor of any of his duties or responsibilities of timely completion of the work under the contract.

#### **7. Contractor's Superintendence**

The Contractor shall engage at his cost an experienced and qualified whole time technical personnel to be in day to day charge of the work and he should be authorized to receive instructions from the Engineer-in-Charge or his authorized representatives like Assistant Engineer and Junior Engineer. He shall receive orders given by the E.I.C. from time to time and shall take action on them promptly. Besides the technical personnel, the Contractor shall maintain at his cost Supervisors having sufficient training and experience to supervise various items and operations of the supervision of works by the Contractor at his cost. The contractor shall furnish the names of the above technical personnel within 15 (fifteen) days of receipt of work order. During execution, technically qualified supervisory staff should be provided at each site with site order book.

#### **8. Contractor to Arrange All Labour : Materials : Tools & Plants**

Unless otherwise specifically provided for in the schedule of materials attached to the Bid, all materials required for execution and completion of the work shall be of approved type and as per specifications and shall be procured, brought at site and stored by the contracting firm at his cost and risk. The rates quoted shall be inclusive of all costs of materials, labour, transportation, storage.

These rates shall also cover all taxes viz. GST, any local taxes, duties etc. that are payable by the firm under the law of the land. Statutory increase on such elements, if any during the period of contract shall not be paid extra.

#### **9. Site Order Book**

The Contractor within 7 (seven) days from the written order to commence work shall supply at his own cost, a site order book to be kept at all the working site of work under the custody of the Assistant Engineer or his authorized representative. The site order book shall have numbered pages in triplicate which will be initialed by the Assistant Engineer. The directions or instructions from the Departmental Officers to be issued to the Contractor will be entered (in triplicate) in the site order book (except when such direction given by separate letters). The

Contractor or his authorized representative/agent shall regularly note the entries in the order book and also record thereon the action taken or being taken by him in compliance with such directions or instructions including any other relevant point relating to the work.

The Contractor or his authorized representative/agent may take away the duplicate pages of the site order book for his own record. A duly authorized representative/agent of the Contractor shall receive such instructions as above.

#### **10. Delay in Getting Site of Work**

If at any time after the issue of work order, the work, and/or any part thereof cannot be started or shall remain suspended due to public opposition, non-availability of site, delay in shifting public utilities or for any other reason whatsoever within the period of completion of work, the Contractor shall be granted necessary extension of time in accordance with relevant clause of WBF 2912. But, he shall have no claim for extra payment or compensation whatsoever on the grounds of above delay. If, however, the above hindrances are not removed within the schedule time and the Contractor is not agreeable to execute further works in the extended time, the Bid may be terminated and the Contractor shall have no claim for any payment on account of idle labour, establishment etc. or compensation whatsoever on account of any profit or advantage which he might have derived from the execution of the aforesaid work in full or in part.

#### **11. Survey : Layout and Access**

The Contractor shall satisfy himself regarding the correctness of the site Layouts, levels etc. as shown in the drawings or given in the specifications. Before starting the work he shall also carry out layout survey of the whole work site jointly with the Department. Discrepancies noticed between Departmental drawing and the joint survey shall be informed in writing to the Engineer-in-Charge and got corrected by the Engineer-in-Charge. Such deviations as may arise out of the joint survey shall not vitiate the provisions of contracts and shall not entitle the Contractor for any extra payment of claim in any way. The Contractor shall provide for all arrangements labour, equipments and materials needed for carrying out layout survey, setting out, layout checking, inspections measurements, testing at his own cost for which no separate payment will be made. The Contractor shall also provide proper approach and access to all the works and stores including clearance of sites at his own cost.

#### **12. Arrangement of Land**

If on account of restriction of space within the project site, the Contractor experiences difficulties on installation of plant and machinery and also in stacking construction materials within the project site, he may have to arrange for lands (Road side flank, private land etc.) adjacent to the project site at his own and at his cost. The Contractor will not be entitled for any payment or any other incidental charges caused due to such arrangement. The work programme and plan of works shall have to be drawn accordingly.

#### **13. Site Godown**

The Contractor must provide at his own cost, suitable godown for cement, MS/Tor/HYSD bars and other materials at/near the site of work as may be instructed by the Engineer-in-Charge.

The Cement godown shall have adequate capacity and shall be constructed as per directions of Engineer-in-Charge. The godown should be readily accessible and open to inspection by any officer of MEDD etc. at any time during the pendency of the Contract.

#### **15. Watching, Guarding and Lighting**

The contractor shall in connection with the works provide and maintain at his own cost all light, guards, fencing and watching when and where necessary or as required by the Engineer-in-charge, for the protection of the works, or for the safety and convenience of the existing plant, contractor's employees, employers supervisors or for any other reason deemed fit by the Engineer-in-Charge. During execution and even up to O & M period, the agency is liable for guarding the materials, equipments, machinery and structures etc. Any pilferage, if occurred, that is to be replenished at his own cost.

## **16. Discrepancies**

If there is any discrepancy in any of the documents and drawings included in this contract or between different parts of the same documents or any ambiguity or insufficiency of information, the contractor shall point out the same to the Superintending Engineer/Executive Engineer in writing and receive his instructions, explanations or decision in the matter. Decision of Superintending Engineer is final and binding on the Contractor.

## **17. Materials to be Supplied by Contractor**

The contractor shall supply all materials except those supplied by the Department. The quality of such materials shall conform to the requirements of the BIS (Bureau of Indian Standard), P.W.D. or any other approved standard specification. In all cases, the latest modification or revision of such specifications will be applicable for use. All IS standard materials should bear IS mark as per BIS. All sampling, testing and transportation of such materials shall take place under the direction of the Engineer-in-Charge at the testing laboratory as may be designated by the Department at the cost of the Contractor. Tests will be made in accordance with the standard methods of testing of the I.S. or other standard specifications. The Engineer-in-Charge has full power to reject or condemn any workmanship or materials that he may deem unsuitable. All materials not conforming to the requirements of these specifications shall be considered as defective and shall be rejected for use and shall be removed by the Contractor from the site of the work within 24 hrs. at his own cost.

In case of non-compliance with such orders, the Engineer-in-Charge shall have the full authority to cause such removal at the cost and expense of the Contractor and the contractor shall not be entitled for any loss or damage on that account. The Engineer-in-Charge will have full right to inspect the store of Contractor for the use of this contract work. All materials and workmanship shall be of the respective kinds described in the contract and in accordance with the Engineer-in-Charge's instructions and shall be subjected from time to time to such tests as the Engineer-in-Charge may direct at the place of manufacture or fabrication, on the site or at such other place or places as may be specified in the contract, or at all or any of such places. The Contractor shall provide such assistance, instruments, machines, labour and materials as are normally required for examining, measuring and testing any work and the quality, weight or quantity of any materials used and shall supply samples of materials before incorporation in the works for testing as may be selected and required by the Engineer-in-Charge, be it at site or at the manufacturer/Vendor's premises. Contractor will have to procure materials from manufacturers /Vendors as may be approved by the E.I.C. No variation will be allowed. Contractor will have to furnish original documentary evidence of procurement of the materials from the specified agencies along with their Certificate of Guarantee/Warranty along with two sets of photo copy of the same to the EIC before release of payment. The EIC will keep one set of photo copy with him and send the other set to the Superintending Engineer after due authentication by him. The original document will be returned to the contractor thereafter by the EIC. The materials that will be supplied by the contractor has to be tested by the Third Party inspecting agencies like B.V. / Crown / E.I.L. / Rites / D.G.S. & D. / Mecon / CIPET / SGS India Pvt. Ltd. / ITENG Engineering / Superintendence Company of India (P. Ltd.) already approved by the Department. Cost of samples – all samples of materials as may be required by the Engineer-in-Charge shall be furnished by the Contractor at the cost and expense of the Contractor. As the rate for completed items of work are inclusive of supply of stone, sand materials, the Contractor shall arrange for procurement of such stone, sand materials required for the work by his own resources and it shall be clearly understood that the Deptt. Shall not sponsor any traffic movement by wagon for stone materials etc.

## **18. Workmen's Compensation**

In every case in which by virtue of the provisions of the Workmen's Compensation Act, 1923, and any other relevant Acts and Rules, compensation to a workman employed by the Contractor, is payable, then this should be done by the Contractor. If the Department is obliged to make any compensation under the said Rules and Acts, then the amount shall be recovered without prejudice, from the bills and dues of the Contractor. The Department shall not be bound to contest any claim made against it in respect of workmen's compensation.

## **19. Hours of Work: Night Work**

All works enumerated in the bid including other works in connection therewith or incidental thereto, shall be carried out during the hours of sunrise to sunset. No works will be held on Sunday's and Holiday's except with the special permission of the Engineer-in-Charge. For all works in the area, Contractors may have to execute the work during night as well as per direction of the Engineer-in-Charge with arrangement of necessary lights, barricades etc. The E.I.C. may also specify the nature of work to be carried out during night. No extra claim or compensation will be admissible for night work or any ancillary work there to save and except which



has been provided in the schedule of work.

#### **20. Contractor's Employees**

No labour below the age of eighteen years shall be employed on the work. Any labour supplied by the contractor to be engaged on the work on day work basis either wholly or partly under the direct order or control of his representative shall be deemed to be a person employed by the Contractor.

The Contractor shall comply with the provision of all labour legislation including the requirement of the Payment of Wages Act and the rules framed there under and modifications thereof in respect of men employed by him in carrying out the contract. The Contractor shall comply at his own cost with any order or requirement of any Health Officer of the State or any local authority and the Engineer-in-Charge regarding the maintenance of proper environmental sanitation of the area where the contractor's labourers are housed or

accommodated, for the prevention of any communicable diseases. The Contractor shall provide, maintain and keep good sanitary condition and provide facilities for potable water at all times for the use of men engaged on the work and shall remove and clear away the same on completion of the work. Adequate precaution shall be taken by the Contractor to prevent nuisance of any kind in the site of work. The Contractor shall provide efficient medical attendant and care for his staff and for the workmen employed to the satisfaction of the Engineer-in-Charge or his representative. The Contractor shall arrange to provide first aid and treatment facilities to the labourers engaged on the works. The Contractor shall within 24-hours of the occurrence of any accident at or about the site in connection with the execution of the work, report each accident to the Engineer-in-charge and also to the competent authority where such report is required by law.

#### **21. Safety Measures and Public Convenience**

The Contractor shall in the course of execution of the work take all necessary precautions for the protection of all persons and property at his cost. The entire site of works shall be well illuminated from sunset to sunrise at his cost. The Contractor shall take adequate measures to protect the work and prevent accidents during the Project work and prevent accidents during the construction. He shall provide and maintain temporary side-walks access to construction site and where necessary, danger signals, Road closed sign, watchman and necessary appliances for properly safeguarding life and site of work for safety. The lamp must be kept lit from sunset till at least one hour after sunrise. He shall protect all excavations equipment and materials with barricades and danger signals so that no life may be endangered. The contractor shall include all costs for these works within his rates and no extra claim whatsoever on this account will be entertained. The Contractor shall so conduct his operation as to cause the least possible obstruction and inconvenience to the other users and contractors in adjacent site. He shall have under construction not more than such amount of work as he can handle properly with due regard to the right of others.

#### **22. Loss and Damage**

Neither the department nor the Engineer-in-Charge or his representative shall be answerable or accountable in any manner for any loss or damage that may happen to the work or any part thereof or to any of the materials or other things used in the performing the work, or for injury to any person, either a workman or any member of the public, or for damage to any property for any cause which might have been prorogated by the Contractor. The Contractor shall properly guard against all these injuries or damages to persons or property resulting from his operations under this contract at any time before issuance of the certificate of completion and maintenance. He shall indemnify and save harmless the Department from all suits or actions of every description brought for, or on account of, any injury or damage received or sustained by any person or persons by reason of the construction of the work, negligence in guarding the same, the use of improper materials or of any act of omission or deviation from the contract.

#### **23. Supervision of Work**

The Engineer-in-Charge shall have the power at any time and from time to time by notice to the Contractor to delay or suspend the progress of the work or any part of the work during unsuitable weather for any other adequate reasons and on receipt of such notice, the Contractor shall forthwith suspend further progress of the work until further notice from the Engineer-in-Charge. The Contractor shall recommence work immediately on receiving a notice to do so from the Engineer-in-Charge. The whole or any part of the time lost for such delay or suspension shall, if the Department in its absolute discretion thinks fit but not otherwise, be added to the time allowed for completion. But the contractor shall have no claim for extra payment or compensation whatsoever on the grounds of above delay.

#### **24. Department's Right to Terminate Contract**

If the Contractor should be insolvent or bankrupt, (or in case the Contractor is a Company, it goes into voluntary or judicial liquidation) or he should make a general assignment for the

benefit of his creditors or a receiver should be appointed on account of his insolvency, or he should persistently or repeatedly refuse or should fail, except in cases for which extra of time is provided, to supply enough properly skilled workmen or proper materials, in order to maintain progress according to the progress of work, or he should fail to make prompt payment to labour contractors if any, or for materials or labour, or he should positively by laws, ordinance or the instruction of the Engineer-in-Charge or otherwise be guilty, of a substantial violation of any provision of the contract after giving the Contractor seven days written notice terminate the employment of the Contractor.

#### **25. Occupying Prior to Completion**

The Department expressly reserves the right to occupy at any time and for so long a time as the Engineer-in-Charge, may be notice in writing to the Contractor, require any portion or portions of the site of works, whether the works to be executed thereof be commenced or in progress or completed and to employ thereon agents and workmen other than the contractor or his men in the execution of matters not included in the contract.

The Contractor shall not obstruct such agents and workmen, and without extra charge and without relief from any liabilities or responsibility, or such allowance provide them free access to the work and to such facilities as in the judgment of the Engineer-in-Charge may be reasonably required.

#### **26. Supplementary Specification**

Whenever reference is made in these documents to certain special specifications, the references shall be construed to include all subsequent amendments, changes or additions that are published and in effect at the date of signing of this contract. The department reserves the right to issue additional conditions, specification etc. if necessary which will be incorporated with bid documents for the purpose of this work.

#### **27. Clearance of Site on Completion**

On the completion of the works the Contractor at his cost shall clear away and remove from the site all constructional plant, surplus materials, rubbish and temporary works of every kind, and level the whole of the site and works clean and in a workman like condition to the satisfaction of the Engineer-in-Charge. The Contractor at his cost shall take care for cleaning the working site from time to time for easy access to work site and also from safety point of view.

#### **28. Land for Contractor's Establishment**

For the purpose of constructing Contractor's Store yard, godowns, site office and ancillaries, he may utilize portion of the land belonging to the Employer at such location as would not interfere with the execution of works. For all these, the Contractor shall have to obtain the requisite permission of the Engineer-in-Charge as per rules in vogue. The Contractor shall for this purpose submit to the Engineer-in-Charge for his approval a plan of the proposed layouts for the site facilities. The Engineer-in-Charge reserve the right to alter and modify the Contractor's proposals as he may deem fit. In case sufficient land is not available with the Employer, the Contractor will have to arrange for private land at his cost to meet his requirements.

#### **29. First-Aid Facilities**

The Contractor shall provide at his own cost for medical attention to be promptly available when necessary. He shall for this purpose provide a number of First-Aid stations at suitable location within easy reach of the workmen and other staff engaged in the Works. Each First-Aid station shall be properly equipped and will remain in charge of a suitably qualified person. The Contractor shall also provide for transport of serious case to the nearest hospital. All these arrangements shall be to the approval of the Engineer-in-Charge. The Contractor shall provide, to the satisfaction of Govt. or Local Authority concerned, adequate medical attendance for his employees and labours.

#### **30. Fire Fighting Arrangement**

The Contractor shall provide at his own cost suitable arrangement for fire fighting. For this purpose he shall provide requisite number of Fire-Extinguishers and adequate number of buckets, some of which are to be always filled with sand and some with water. These equipments shall be provided at suitable prominent and easily accessible places and shall be properly maintained.

#### **31. Department's Right to Split Package**

The Tender Inviting Authority reserves the right to split the package and accept or reject any part of the offer from the scope of work without assigning any reason.

#### **32. Construction Records**

The Contractor shall keep and supply to the Engineer-in-Charge the up-to-date records of the dimensions and positions of all permanent works (showing therein any approved deviation between the drawing and the work as actually executed). The information available from the

records must be adequate and complete to enable preparation of completion drawing by the Contractor at his own cost from these records.

### **33. Test for Water Tightness of Collector Well, Reservoir, pipes, valves etc.**

The Collector Well, R.C.C. Elevated reservoir, CWR and other water retaining structures shall be tested for water tightness as per relevant IS code by filling it with fresh potable water up to its designed full supply level. The shell, floor etc. of the tank are to be made perfectly water tight and for doing so, the contractor shall use water proofing compounds which should be taken into consideration while calculation of the rates for relevant item of the bid and no extra charges whatsoever will be entertained on this account. The contractor or his authorized representative must give a test performance for water tightness of the tank shell and floor (by filling the tank with water) to the satisfaction of the E.I.C or his authorized representative. He should note that all necessary appliances and materials including water required to carry out such testing should be borne by him and no payment will be made on this account except what has been provided in the schedule. The contractor shall also rectify/replace any defects immediately after the same is detected during the water tightness testing at his cost as required and directed by the E.I.C. The contractor shall carry out testing operations again till successful completion of the test. On completion of satisfactory testing and disinfection as mentioned elsewhere in relevant clause of the bid, the contractor shall refill the Collector Well, R.C.C. elevated reservoir, CWR up to its full capacity with fresh potable water to keep the Collector Well, Reservoir /CWR in full load condition till its commissioning (ignoring losses due to evaporation) as per relevant item of the schedule.

Similarly, all pipe lines have to be tested for their respective hydrostatic pressure as per relevant I.S. code of practice till satisfactory test is achieved. The contractor shall have to make arrangement for water tightness testing as mentioned above by making arrangement at his cost for supply of water, its filling and disposal of water after the tests. The rates quoted by the contractor shall be inclusive of the cost of labour, materials, equipment and machinery required to give successful tests for water tightness. No extra cost in this respect will be given except what has been provided in the schedule of work.

### **34. Satisfactory completion of various items**

The various items of the sub-work are to constitute the whole work should be completed in every respect as per satisfaction of the Engineer-in-Charge. Each sub-work will be considered as complete when it is completed as per drawing & specifications, as per standards, as a successful component part of the whole work.

### **35. Reports and Returns**

The Contractor shall maintain at Site daily records of progress with regard to the works carried out, labour engaged and construction equipment deployed. These will form the basis of preparing periodic reports and returns as may be required by the Engineer-in-Charge and in the manner as directed by him. These daily records shall be made accessible to the Engineer-in-Charge or his Representative as and when desired by him. The Contractor shall also submit a weekly return on the first day of each week for the preceding week showing up-to-date progress and progress during the previous week of all important items of work.

### **36. Terms & Stages of Payment**

Subject to deduction of Initial Security Deposit (2%), Security Deposit (8%) and any others in vogue, progressive payment may be made against the completion or partly completed item of works on prorata progress. Such interim payments, however, shall not be construed to mean that the respective items/components have been finally approved and accepted by the Department and the Contractor shall not be absolved of his responsibility set right at his cost any defects/deficiencies which may subsequently come to light.

The payment for the items executed will be released as per payment milestone/payment break up schedule of the tender Document. Prorata deduction will be made for less execution of works. No claim for interest or compensation will be entertained in respect to any money or balance which may be due or alleged to be due to the Contractor owing to any dispute between the Department and the Contractor or in respect to any delay in making payment or progressive original bill to the Contractor. Payments will be made as per availability of fund.

### **37. Insurance of works, etc.**

Without limiting his obligations and responsibilities, the Contractor shall insure in the names of the Employer and the Contractor against all loss or damage from whatever cause arising for which he is responsible under the terms of the contract and in such manner that the employer and Contractor are covered for the period of execution as well as during the period of Maintenance for loss or damage arising from a cause, and for any loss or damage occasioned by the Contractor in the course of any operations carried out by him for the purpose of complying with his obligations as follows:

(a)	The works for the time being executed to the estimated current contract value thereof together with the cost of materials
(b)	The Constructional Plant and other things brought on to the site by the Contractor and the replacement value of such constructional Plant and other things. These shall include materials belonging to the Employer but issued to or intended to be issued to the Contractor for use in the work. Such insurance as mentioned in para (a) and (b) above shall be effected with an insurer and in terms approved by the Employer. The Contractor shall bear the cost of all such insurance and whenever required, produce to the Engineer-in-Charge or his representative the policy or policies of Insurance and the receipts for payment of the current premiums.

### 38. Damage to Persons and Property

The Contractor shall, except ;if any so far as the contract provides otherwise, indemnify the Employer against all losses and claims in respect of injuries or damage to any person or materials or physical damage to any property whatsoever which may arise out of or in consequence of the execution and maintenance of the works and against all claims, proceedings damages, costs, charges and expenses whatsoever in respect of or in relation thereto except any compensation or damages for or with respect to:

(a) The Permanent use or occupation of land by the works or any part thereof.

(b) The right of the employer to execute the works or any part thereof on over, under, in or ) through any land.

( c ) Injuries or damage to persons or property which are the unavoidable result of the execution or maintenance of the works in accordance with the contract.

(d) Injuries or damage to persons or property resulting from any act or neglect of the Employer, his agents, servants or other contractors, not being employed by the Contractor, or for or in respect of any claims, proceedings, damages, costs, charges and expenses in respect thereof or in relation thereto or where the injury or damage was contributed to by the Contractor, his servants or agents such part of the compensation as may be just and equitable having regard to the extent of the responsibility of the Employer, his servants or agents or other contractors for the damage or injury.

### 39. Accident or Injury to Workmen:

The Employer shall not liable for or in respect of any damages or compensation payable at law in respect or in consequence of any accident or injury to any workman or other; person in the employment of the Contractor or any sub-contractor, have and except any accident or injury resulting from any act or default of the employer, his agents, or servants. The Contractor shall indemnify and keep indemnified the Employer against all such damages and compensation, save and except as aforesaid and against all claims, proceedings, costs, charges and expenses whatsoever in respect thereof or in relation thereto.

### 40. Insurance Against Accident etc. to Workmen:

The Contractor at his cost shall insure against all liabilities indicated in clause 40, 41 and 42 with an insurer approved by the Employer, and shall continue such insurance during the whole of the time that any person is employed by him on the works and shall, when required, produce to the Engineer-in-Charge or his representative such policy of insurance and the receipts for payment of the current premium. Provided always that, in respect of any persons employed by any sub-contractor, the Contractor's obligation to insure as aforesaid under this sub-clause shall be satisfied if the sub-contractor shall have insured against the liability in respect of such persons in such manner that the Employer is indemnified under the policy, but the Contractor shall require such sub-contractor to produce to the Engineer-in-Charge when required, such policy of insurance and the receipt for the payment of the current premium.

### 41. Notification to Insurer:

It shall be the duty of the Contractor to notify the insurers under any of the insurances referred any matter or count which by the terms of such insurances are required to be notified and the Contractor shall indemnify and keep indemnified the Employer against all losses, claims, demands, proceedings, costs, charges and expenses whatsoever arising out of or resulting from any default by

the Contractor in complying with the requirements of this sub-clause whether as a result of the avoidance of such insurance or otherwise.

**42. All Insurance at Contractor's Cost :**

The insurances referred to in this Bid document shall be entirely at the cost and expense of the Contractor.

**43. Remedy on Contractor's Failure to Insure :**

If the Contractor shall fail to effect and keep in force the insurances referred to in Clauses here to or any other insurance which he may be required to effect under the terms of the Contract, then and in any such case the Employer may effect and keep in force any such insurance and pay such premium or premiums as may be necessary for that purpose from time to time and deduct double the amount so paid by the Employer as aforesaid from any monies due or which may become due to the Contractor, or recover the same as a debt due from the Contractor.

**44. Initial Security Deposit, Security Deposit, Special Security Deposit.**

**i) Initial Security Deposit**

The earnest money deposit of successful bidder @ 2% (Two percent) of the value of the work or the sum mentioned in e-Tender Notice deposited online as per **G.O. No. 3975-F(Y) dt.28.07.2016 of the Audit Branch, Finance Department. Govt. of West Bengal**, will be retained as initial Security Deposit. The said sum of 2% will be adjusted against subsequent deduction of security deposit from each and every progressive bill.

**ii) Security Deposit**

Balance Security Deposit @ 8% (eight percent) will be deducted from each and every progressive bill. The entire amount of total 10% (ten percent) of Security Deposit (Initial 2% + Additional 8%) shall be refunded without any interest on completion of each and every year of O & M only after completion, commissioning with trial run of the scheme. Security Deposit (10%) in the form of Bank Guarantee on any nationalized bank is acceptable if the accepted contract value is more than 15 (fifteen) Crore except O & M cost.

**iii) Performance Guarantee**

An amount @5% of the bill value will be deducted in addition to other deductions from each progressive bill and will be retained as special security deposit if water tightness test of OHRs, CWRs & other water retaining structures and hydraulic testing of pipe lines is not done. The retention money will be released after successful completion of tightness test of OHRs, CWRs & other water retaining structures or hydraulic testing of pipe lines.

**iv) Additional Performance Security:**

Additional Performance Security @ 10% of the Tendered amount shall be submitted by the successful bidder if the accepted bid value is 80% or less of the estimate put to tender in term of G.O. No.4608-F(Y) dt.18.07.2018 of Finance Department. Govt. of West Bengal.

<b>45.</b>	<b>Inspection Facilities</b>
	The Contractor shall provide necessary facilities for inspection of work for quality control by the Engineer –in-Charge or his representative and for the purpose of carrying out his instructions as may be recorded in writing in site Order Book.

**46. Testing & Testing Equipment**

Testing of materials to be used in the permanent work or of the quality of finished items, shall have to be done from approved laboratory at the expense of the Contractor.

If the E.I.C. considers it necessary to satisfy himself as to quality of work, the Contractor shall offer sample of work done as necessary, pull down reasonable part of the work required for such inspection and testing. The contractor shall bear the cost of pulling down and shall make good the same at his own cost and to the full satisfaction of the E.I.C. without any extra cost. The Contractor shall provide at his own cost necessary equipments for such testing which by nature of work may have to be done at work site. These include sufficient number of slump cones, standard 150 mm metal cube moulds, set of I.S. sieves, weighing balances, graduated measuring cylinders, equipment for in-situ density test, holding detector, thermometers and any other miscellaneous equipment that may be required by the Engineer-in-Charge. The Contractor shall also provide at his cost facilities for curing of concrete cubes for testing purpose. The Contractor shall afford at his own cost necessary facilities in providing requisite materials and assistance that may be required by EIC including transportation

charges to laboratory.

#### **47. Idle Labour**

No claim for idle labour would be entertained under any circumstances.

#### **48. Labour Act**

The Contractor should obtain the license under the provision of the Contract Labour (Regulation and Abolition) Act 1970 and the Contract Labour (Regulation and Abolition) General rules, 1971 including the provisions of amendments made there under and submit the same to the office of the Executive Engineer within ten days after formal agreement. The successful bidder whose bid will be accepted shall either personally deliver the license form in triplicate to the Licensing Officer of the area in which the establishment in relation to which the Contractor is selected for the job. The application form in Form IV shall be forwarded along with Form V which may be available from the Engineer-in-Charge of the concerned Division.

#### **49. Local Employment**

No labour/skilled labour should be imported from any district other than where works are to be executed without prior consent of the Executive Engineer. Imported labour /skilled labour can only be engaged with permission of the Executive Engineer when the exigency or progress of work so demands and sufficient local labours are not available.

#### **50. Import License and Imported Equipments**

Use of any imported equipment for the work is not envisaged. However, if it becomes absolutely necessary, requisite Foreign Exchange and import license shall have to be arranged for by the contracting Firm independently and the Dept. will not take any responsibility in this regard. A certificate stating the necessity of the particular materials for the work entrusted to the firm may be issued at its discretion by the Dept. at the request of contracting firm. Delay in getting any materials will not be entertained for extension of time limit of contract.

#### **51. Water Supply , Sanitation & Power**

The Contractor shall have to make his own arrangement for supply of electrical power and water at all stages of execution of work. Arrangement for obtaining water for the work as well as for the labourers and sanitation facilities for labourers shall have to be made by the Contractor at his cost. The quality of water shall be conducive for construction works in terms of soluble, insoluble materials and chloride content]. The cost of erection/installation for obtaining either electricity or water from W.B.S.E.D.C.L or Burdwan Municipality or any other agency shall have to be borne by the Contractor for which no extra claim can be placed before M.E. Department & Burdwan Municipality. However, Burdwan Municipality/ MED Directorate may provide power and water if the same is available at site. If the contractor draws power and water from Burdwan Municipality's Point then he is required to pay the charges of power and water as per consumption at the prevailing rates of W.B.S.E.D.C.L/Burdwan Municipality for (i) Power consumption and (ii) Connection for water.

But supply of power and water should not be considered as the responsibility of the Burdwan Municipality/ MED Department. Nevertheless, electrical power from Burdwan Municipality's point may not be continuously available due to various reasons including load-shedding. In that case water supply from Burdwan Municipality's point will also stop and the Contractor will make his own arrangement for water and power through generator at his cost.

#### **52. Storage and Safety of Equipments**

The equipment at site shall have to be stored in water proof shed with proper security arrangement made by the contractor within his quoted price. The Contractor shall insure at his cost all the equipment against pilferage and breakage at site during storage and erection under their custody till the work is completed and handed over to the Employer.

#### **53. Language for Correspondences**

All written materials and correspondence in connection with the contract shall be in English.

#### **54. Contractor's Local Address**

The Contractor shall furnish the postal address of his site Office. Any notice or instruction to be given to the Contractor under the terms of contract shall be deemed to have been served if it has been delivered to his authorized agent or representative of site or sent by registered letter to the site office

or to the address.

#### **55. Recoveries**

Any recovery from the Contractor advised by the Employer/Government shall be recovered from many bill of this contract.

#### **56. Reduced Rates**

Reduced rates as decided by the E.I.C and subsequent approval from concerned Superintending Engineer shall be allowed for the works which in the opinion of the E.I.C. are not done in strict conformity with specification but are acceptable. Works which are not in conformity with the specification and not acceptable in the opinion of E.I.C. will not be paid for and the cost of rectification or dismantling of such unacceptable work will have to be fully and solely borne by the Contractor.

#### **57. Minimum Wage Act**

The Contractor is required to follow the provisions of Minimum Wage Act.

#### **58. Precedence of Contract Documents**

If any stipulation indicated in any component of contract documents be at variance in any respect with those in the other, the decision of the Superintending Engineer will stand final and binding.

#### **59. Time of Completion**

The entire work as per offer shall be completed within specified time as mentioned in tender notice from the date of issue of work order. The time of completion is firm and final and supersedes any other time mentioned elsewhere in any clause(s) of bid document. After the acceptance order is issued by the Bid inviting authorities, the selected Contractor shall forthwith contact the Executive Engineer and furnish within 10(ten) days of necessary Licenses, clearance – certificates and copies of papers in consultation with him to enable issuance of work order without undue delay. In case the contractor fails to submit the papers within time, the department shall not be responsible for the delay in issuance of work order. In that event, time of completion shall be counted from the date of issue of work order.

The period of completion given includes the time required for mobilization and testing as well, rectifications, if any, re-testing and completion in all respects to the entire satisfaction of the Engineer-in-Charge including the monsoon season.

A joint programme of execution of work will be drawn up by EIC and contractors indicating the monthly/weekly construction programme based on availability of work fronts. The contractor shall scrupulously adhere to these targets/programme by deploying adequate personnel and construction tools and tackles and he shall also supply all materials of his scope of supply in time to achieve the targets set out. The contractor shall give every day to day report on category-wise labour and equipment deployed along with the progress of work done on previous day. The progress of work shall be proportionate to completion time.

#### **60. Action for Non-Compliance**

Failure to comply with above conditions and specifications will result in the department taking action at the risk and cost of the Contractor. Submission of the bid binds the Contractor for complying with requirements of the above conditions and specifications without any extra payment on any account.

#### **61. Progress Photographs**

The Contractor shall at his own cost and expenses, arrange to take periodic still photographs to show the progress of work or interesting features thereof. The time and the position wherefrom a photograph is to be taken would be as per direction of the Engineer-in-Charge or his Representative. Two coloured prints of each of these still Photographs to an enlarged size of about 25 cm x 15 cm together with the softcopy, shall be supplied to the Engineer-in-Charge in albums by the Contractor at his cost and these shall become the property of the Employer. Each photograph shall be suitably captioned with the date of the photograph, location and other relevant particulars. Restrictions to photography or security restrictions that maybe applicable to any particular area, must be carefully and rigidly observed. The number of still photographs (each

consisting of twoprints and the softcopy as aforesaid) for the complete works have to submitted to EIC once it isasked to submit.

**62. Deduction of Tax**

Deduction of Good Service Tax, Income Tax, Labour welfare cess and any other taxes payableas per prevailing Tax Laws at the prescribed rate will be made at the time of making payment tothe Contractor.

**63. I.E. Act.**

The Contractor is required to comply with the I.E. Act and Rules framed there under. He will have to produce to the EIC evidence of possession of Electrical Contractor's licence with current validity and also copy of Electrical Supervisor's Certificate with qualification, registration no.etc. in respect of employees involved in electrical works.

**64. Typographical Error**

Any arithmetical/typing mistake/ mistake in spelling or common attributes in nomenclature, and,or, mistake in unit rate of items in the BOQ shall be corrected in respect of Schedule of Rates ofPWD/MEDD and treated as a part of Tender Document, even after issuance of Acceptance/Formal Work Order(s) upto the period of finalization of Tender including usual security/defect liability period of contract.

**65. Completion Certificate:**

The Engineer-in-Charge will issue certificate of completion of work when all works itemized inthe Schedule of work or otherwise undertaken have been completed in all respect including successful hydraulic testing of the R.C.C Elevated Reservoir /CWR, other water retaining structures, pipes, valves etc., yield testing of Collector Well and Maintenance period will start from the date of issue of completion certificate.The Final Bill for the work shall be paid by EIC on completion of work in all respect includingsubmission of the following documents by the Contractor in quadruplicate.

a) Material reconciliation statement.

b) Completion drawing showing salient details e.g. pipe diameter, length, location & type of valve, location of all specials (bend reducer, collar etc.) for bye pass inlet, outlet, overflow & wash out lines of Reservoir.

c) Still photographs of work execution.

d) Disinfection and rinsing results duly signed by Contractor and accepted by the EIC.

e) Leak proofness results duly signed by Contractor and accepted by the EIC.

f) As built drawing of all Components of the Scheme.The EIC shall send one set of documents as indicated above to the Superintending Engineer,before making final payment.

**66. Disinfection:**

The inside of the Collector Well, CWR, other water retainingstructures, pipeline etc. should be cleaned and flushed with water before water tightness and leakproofness testing. Thereafter disinfection shall be performed in the following manner. Thesystem shall be drained completely. All valves shall be closed carefully and the system shall befilled with a strong chlorine solution of about 50 ppm free chlorine. This solution shall remainin the system for a period as directed but not exceeding 24 hours uninterruptedly. Chlorineresidual test shall be done at various points by an ortho-tolidinereagent with a colour scale. Thedisinfection process shall be repeated until residual chlorine is not less than 10 ppm at allsampling points. After disinfection, the entire pipe line shall be rinsed with potable water tillresidual chlorine is less than 4 ppm at various points of testing and a report indicating the resultsbe given by the contractor to the E.I.C.Afterdisinfection and rinsing, the reservoir shall be re-filled by potable water up to its full capacity.

**67. Safety Requirements:**

CONTRACTOR shall use safety belts, whenever his workmen work at a high altitude to avoid risk of any accident or fall Hard Top Hats to be used by the CONTRACTOR's workmen at the places wherever required.

Necessary Fire Protection arrangements by installing portable fire extinguishers on suitable



locations at work site and material storage area should be made by the contractor at his own cost. The CONTRACTOR shall also use Safety devices like Welder's apron, hand gloves, goggles, helmets etc. and other accident preventive arrangement at work site as per prevailing safety code. First aid and other medical facilities to be provided at the work site by the CONTRACTOR. CONTRACTOR's personnel working at site should have Identity Badges during their stay inside the plant. Prior approval of identity badges or cards by Engineer-in-Charge shall be obtained by the CONTRACTOR. The CONTRACTOR shall take all precaution for work safety and to prevent accident to men working under him or to other CONTRACTOR's working at site.

**The Chairman/ Administrator**

**Burdwan Municipality**

## **SECTION - J**

### **PROCESS DESCRIPTION AND DESIGN PARAMETERS**

#### **ADDITIONAL CONDITIONS OF CONTRACT**

1. Tenderer is to ensure that the tender documents for agreement contain signature and stamp of the issuing officer, without which the same will not be considered as valid documents
2. Tenderer or his authorized signatory shall sign each page of tender documents, drawing etc. with date and seal before submission of the same. Tenderers must comply with all the norms prescribed in the Tender documents.
3. No interest will be allowed for holding earnest money or Security deposit.

4. Any conditional tender or tender with changes in original tender documents may be liable for rejection. It is clarified that Tenderers will not be entitled to put or impose any condition in the tender documents.
5. Over-writing in the tender documents or defacing the same shall not be allowed. Correction, if any, to be made should be crossed through under the signature of the authorized person or person signing the tender and correction should be written afresh in ink. No white / other correction fluid shall be used.
6. The offered price of the tender shall remain valid for acceptance for a period of 180 days from the due date of submission of the tender. Tender, once offered cannot be withdrawn within the aforesaid period of 180 days. If any tenderer desires to withdraw his tender before such time, his earnest money will be liable to be forfeited without assigning any reason. Further extension of time of validity, for acceptance of the tender will be guided by relevant clause of Form No. 2912.
7. The amount quoted by the contractor shall be deemed to be inclusive inter alia of the GST, Income tax, Cess and other taxes & charges that the contractor will have to pay for performance of this contract. The EIC will perform such duties in regard to the deduction of such taxes & charges as per law.
8. Typographical errors detected or pointed out are subject to corrections by tender inviting authority. Any party on account of such error can derive no benefit.
9. The Department may at his discretion, ask any Tenderer for clarifications / confirmations and the response of the tenderer shall be in writing and shall be considered as part of tender documents.
10. Department, if required, may enter into price negotiation normally with the tenderer, whose tender is economically acceptable and is the lowest evaluated priced tenderer (L1 Party).
11. Tenderers would be at liberty to point out any ambiguities, contradictions, omissions etc. seeking clarifications thereof or interpretation of any of the conditions of contract, specification, drawing etc. of the tender documents before the Tender Inviting Authority during pre-bid discussion as mentioned in the Notice Inviting Tender and beyond such discussion no representation on that behalf will be entertained by the Tender Inviting Authority.
12. The Tenderer is required to carefully study all the tender documents and offer his tender to comply with all the provisions thereof. Submission of a Tender shall be taken as evidence and confirmation that the Tenderer has acknowledged all the provisions of the Tender Document and has fully acquainted himself with site conditions and all factors which may influence the submission of his Tender.
13. All expenses incurred for site inspection and all activities in the preparation and submission of the Tender shall be borne by the Tenderer. No claim in this respect is admissible.
14. Extra claim or any concession on the ground of insufficient data or information and absence of knowledge of conditions prevailing at the site on the ground or underground or situation arising during the excavation of the work shall not be entertained.
15. Tenders which have been considered valid on the result of general examination at the time of opening, shall be subject to subsequent detailed scrutiny. Notwithstanding the general examination carried out earlier, the tender inviting authority reserves the right of rejection of any tender, which may be found to be defective during the detailed scrutiny.
16. Tender will be accepted by the appropriate authority in P. H. Engg. Deptt/ Dte. The Tender Inviting Authority does not bind itself to accept the lowest tender and reserves to itself/himself the right to reject any or all of the tenders received without assigning any reason there for.
17. The successful Tenderer (Contractor) is to obtain Licence from the Registering Officer & Assistant Labour Commissioner of the respective Division / Officer under the Contract Labour (Regulation & Abolition) Act 1970 and rules framed there under and submit the same to the concerned EIC/Authorized representative of the EIC before commencement of the work at site. The contractor is also required to fulfill all the terms and conditions as embodied in the above mentioned Act and Rules made there under.
18. The Tenderer, acceptance of whose Tender will be communicated online, shall, within 15 (fifteen) days from the date of such communication of the acceptance letter shall have to

submit 3 (Three) sets of contract documents to the Office of the Executive Engineer, Birbhum Division, MED Directorate upon signing the same for completing the remaining formalities by the competent authority before issuance of work order in favour of the contractor. Necessary fees for agreement shall be deposited in the Accounts Section of the Division. If the Tenderer fails to comply with the formalities as mentioned above within the said specified period, the acceptance of tender is liable to be cancelled and deposited earnest money converted to security deposit shall stand forfeited in case of such cancellation.

19. The contractor shall furnish the postal address of his site office. Any notice or instruction to be given to the contractor under the terms of contract shall be deemed to have been served if it has been delivered to his authorized agent or representative of site or sent by registered letter to the site office address.

20. The Participating tenders shall not be entitled to take undue advantage(s) in any form whatsoever owing to any typographical mistake/omission if found subsequently.

21. The contractor shall within seven days of the receipt of the order to take up works, supply at his own cost site order book to the Engineer-in-Charge. The site order book shall be kept at the site of work under the custody of EIC or his authorized representative. The site order book shall have machine numbered pages in triplicate. Directions or instructions from Departmental officers to be issued to the contractor will be entered (in triplicate) in the site order book (except when such directions or instructions are given by separate letter). The contractor or his authorized representative shall regularly note the entries in the site order book and also record thereof the action taken by the contractor, complying with the said direction, instruction or any relevant point relating to the work. The contractor or his authorized representative may take away the duplicate page of the site order book for his own record.

The first page of the site order book shall contain the following:

- a) Name of the work.
- b) Reference to the contract no.
- c) Contractual price.
- d) Date of opening the site order book.
- e) Name & address of the contractor.
- f) Signature of the contractor.
- g) Name & address of the authorized representative of the contractor authorized by him.
- h) Specific purpose for which the contractor's representative is authorized to act on behalf of the contractor.
- i) Signature of the authorized representative duly attested by the contractor.
- j) Signature of EIC.
- k) Date of actual completion of work.
- l) Date of recording final measurement.

22. No claim for idle labour, establishment and plant & equipment setc would be entertained under any circumstances.

23. The Contractor shall notify the names with qualification of the key personnel engaged for the execution of work within 10 (ten) days to the EIC, from the date of issue of work order,

24. The contractor should submit to the EIC for approval a programme showing the general methods arrangements, order, and timing for all the activities in the works. An update of the program shall be a program showing the actual progress achieved on each activity and the effect of the progress achieved on the timing of the remaining work including any changes to the sequence of the activities. In all such cases bar chart, pie diagram and still photographs shall be submitted in support of

progress report & programme. The contractor shall submit to the EIC for approval, an updated program at intervals no longer than the period of 15 (fifteen) days. The EIC's approval of the program shall not alter the contractor's obligations.

25. The contractor may require to attend review meetings on progress of work as and when

required. The business of a meeting shall be to review the plans for remaining work and to deal with matters raised in accordance with the early warning procedure. The EIC shall record the business of meeting and is to provide copies of his record to those attending the meeting, the tender accepting authority and others. The responsibility of the parties for actions to be taken is to be decided by the EIC either at the meeting or after the meeting and stated in writing to all who attended the meeting.

26. The EIC shall not make any secured advance payment to the contractor in respect of materials intended for but not yet utilized in the works in accordance with the scope of work, specification, drawings & other documents of contract.

27. The contractors shall submit all bills on the printed form to be had on application at the office of EIC. Usually a bill shall be submitted by the contractors each month for all work executed in the previous month and the EIC shall take or cause to be taken the requisite measurement for purpose of having the same verified, and claim as far as admissible adjusted. If the contractor does not submit the bill within the time fixed as aforesaid, the EIC may depute subordinate to measure up the said work in the presence of the contractor, whose counter signature to the measurement list of the measurement book(s) will be sufficient warrant and the EIC may prepare a bill from such list which shall be binding on the contractor in all respects. Unless otherwise stated, the method of measurement for all other works shall be as given in IS:1200 published in several parts.

28. All works enumerated in the tender including other works in connection therewith or incidental thereto shall be carried out normally during the hours of sunrise to sunset. No works will be held on Sundays and Holidays except with special permission of the Engineer-in-Charge. Contractor may have to execute the work during night as well as per direction of the EIC with arrangement of necessary lights, barricades etc. The EIC may also specify the nature of work to be carried out during night. No extra claim or compensation will be admissible for night work or any ancillary work thereto same & except which has been provided as contract price for the work.

29. All written materials and correspondences in connection with the contract shall be in English/Bengali.

30. Lump sum amount for execution of work shall be quoted in Indian Rupees. All payments shall be made in Indian Rupees.

31. Engineer-in-Charge or his authorized representative, if required, shall put to use any unit or portion of work. Acceptance and use of any unit of the works under the scope of the contract shall not constitute a waiver of any portion of this contract and shall not be construed so as to prevent the EIC from requiring replacement of defective work that may become apparent after the said acceptance and also shall not absolve the contractor of his obligations under this contract. It is made clear that such an acceptance does not indicate or denote or establish to the fact of execution of that work or the contract until the work is completed in full in accordance with the provisions of this contract.

32. Arrangement for water, if required by sinking of temporary tube wells, for all the works including cost thereof are to be borne by the contractor. The water should be clean, free from loam, silt or organic materials. No hard water shall be used. Arrangement for electric power including generator set required by the contractor for the work shall also be made by him at his own cost. EIC will, however recommended upon the prayer of contractor to the WBSEDCL for giving connection and power to the contractor. However, the EIC will bear no responsibility in this respect.

33. All excavated earth and materials shall remain the property of the MEDDte., Govt. of West Bengal and the contractor shall be responsible for their disposal of the same at MEDDte. Locations and maintain a measurement of quantity of earth disposed at different locations and submit to EIC along with every submitted bill.

34. Un-interrupted progress of the work to be maintained throughout the year in all season.

35. The contractor shall provide and maintain at his own cost, electrically or other power driven pumps and other plant and equipment to keep the site and foundation pits and trenches free from water and continue to do so till the site is handed over to the complete satisfaction of E.I.C.

36. In general, no material will be supplied departmentally unless mentioned specifically in the Tender document for supply of departmental materials. All the materials shall be procured from the approved vendors after fulfillment of criteria mentioned in Tender documents. The list of vendors for

supplying of materials is enclosed with Tender document. Before releasing bill, contractor will have to submit original documentary evidence for procurement of materials alongwith two photo copies signed by the agency. Original document will be returned to the agency after verification. The E.I.C. will keep one set of photo copy with him after due authentication by him.

37. Inspection shall be carried out, by the third party inspection agency in accordance with quality assurance plan (QAP) approved by E.I.C. at the cost of the contractor / agency. Copies of all inspection calls are to be forwarded by the contractor to the EIC or his authorized representative. The inspection, examination or testing agency shall not, however, relieve the contractor from any of his obligations under this contract.

38. All sampling, testing and transportation of such materials shall take place under the direction of EIC at the testing laboratory and / or at work site as may be designated by the EIC at the cost of the contractor. Testing will be done in accordance with the standard methods of testing of the relevant IS or other standard specification should the EIC consider it necessary to satisfy himself as to quality of work, the contractor shall offer sample of work done as necessary, pull down reasonable parts of the work required for such inspection and testing. The contractor shall bear the cost of pulling down and shall make good the same at his own cost and to the full satisfaction of the EIC.

39. Haulage path / temporary approach road for carriage of materials / spoils to/from site shall be arranged by the contractor at his own cost for uninterrupted / smooth progress of work.

40. Escalation in price is not allowed under any circumstances during the entire period of contract.

**The Chairman/ Administrator**

**Burdwan Municipality**

## **SECTION – K**

### **ADDITIONAL INFORMATION AND SPECIAL TERMS & CONDITIONS**

#### **INFORMATION AND SPECIAL TERMS & CONDITIONS**

1. Design and construction of foundations for all structures are to be carried out by conducting necessary soil test as per relevant IS Codes and specifications.
2. The scheme shall be completed in all respect keeping in view of commissioning, Trial Run and Operation & Maintenance of the scheme.
3. The Department will only provide the land(s) at the locations as per DPR/ Land details provided in the Tender document.

4. All damages done during execution have to be mended it good by the bidder to its original position and for which if any payments to be made to the inter Department and that has to be borne by the successful bidder.
5. All underground pipes shall be laid with a minimum earth cushion of 1.00m. For laying of any type of pipe line underground, if any deviation from required specified clear cover necessary approval from E.I.C. is to be obtained.
6. The rate shall be quoted in lump sum basis and necessary break-up schedule are to be submitted specifically during the time of submission of Bid, but in no case the break-up schedule shall differ from the listed items and payment will be released accordingly subject to the availability of fund.
7. All design and drawings are to be submitted by the successful tenderer unless otherwise mentioned in the Tender Document. Departmental drawings will be issued for the Components which will be executed as per departmental drawing.
8. The rate to be quoted including trial run for a period of 6(three) months and maintenance for 12(Twelve) months including supply of all accessories, manpower, spares / replacements and restoration of defective parts/portion as and when required.
9. All materials should be supplied by the tenderer except those supplied by the department.
10. The provision under this Chapter will follow the provisions of any conditions of contract in W.B.F. 2912 wherever necessary.
11. The work is to be continued throughout the year including in rainy season for timely completion. No delay in execution of work for the reason whatsoever shall be entertained. No price escalation and additional claim for any temporary, additional & other allied works whatsoever shall be admissible.
12. The bidding process will consist of Pre-qualification bid, Technical bid and Financial bid only. All the documents will form Part of Bid Document. Successful bidder, whose bid will be accepted, will have to execute bid agreement in W.B.F. 2912 after completion of formalities as will be required under Government Rules and Regulations.
13. The department reserves the right to issue addenda to the bid document to clarify, amend, modify, delete or supplement any portion of the Technical Specification.
14. Each addendum issued by the Department/Directorate, shall be treated as if the portion added or deleted was there from the very inception of Bid.
15. No bidder shall contact the Tender Inviting Authority on any matter relating to its bid offer after the time of submission of the same unless requested so in writing. Any effort by a bidder to influence the Tender Inviting Authority in the decision in respect of bid evaluation will result in the rejection of that bid.
16. The Tender inviting Authority shall neither be liable for any such action nor be under any obligation to inform the applicant(s) of any grounds concerning the above.
17. No supporting paper(s), data, related information shall be allowed to be submitted/e-mailed by any bidder after submission of bid unless asked by the Department in writing.
18. The Tender inviting Authority shall not be responsible to reimburse any cost incurred by the applicant in preparation and submission of the bid or in connection with any site visit(s) made whatsoever. The intending bidder(s) shall bear all such expenses.
19. All offers shall remain valid for acceptance by the Department for a period of 180 days (One Hundred Eighty Days) from the date of the bid opening.
20. ECS Payment will be made only in Indian Currency through IFMS Module of West Bengal Finance Department's website [www.wbfin.gov.in](http://www.wbfin.gov.in) against completion of individual activity related to different components to be finalized with the successful bidder.
21. The Contractor shall be responsible to maintain satisfactory progress for timely completion of the entire work being prepared that there may be some delays in making payment against running A/c. Bill(s) of the Contract. The Contractor, if necessary, will have to cover up such delays for payments by own arrangement to complete the work in time and within the specified cost without any extra payment.
22. It is mandatory that all the intending applicant(s) should submit "Authorization and Affidavit" as per

prescribed format given in the bid document on a non-judicial stamp paper of Rs. 10/- (Rupees Ten) only duly filled in, affirmed and declared before a 1st Class Judicial Magistrate /Notary Public, during submission of this bid otherwise, the bid shall be treated as informal.

23. The Tender inviting Authority reserves the right to add, amend, omit, modify any of the items of works, shown in the schedule of works of the Bid Documents, as deemed necessary without showing any reason.

24. Each page of the Bid Document for agreement shall have to be signed/ initialed by the authorized signatory with date and seal for execution of deed of contract.

25. Any conditional and or additional offer may be liable for rejection. It is clarified that bidder will not be entitled to put or impose any conditions in the Bid Document.

26. The Technical and Financial Bid will be opened in presence of the bidders who may be present at that time. In case the bidder sending their authorized representative to be present at the time of opening, such authorized representative would have to comply with the requirement producing documents beforehand.

27. Price once offered cannot be withdrawn within 180 days. If any bidder desired to withdraw the offer before such time, earnest money will be liable to be forfeited without assigning any reason. Further extension of time of validity, for acceptance of bid may be done by mutual consent of the bidder and the Tender Inviting Authority.

28. Offers which have been considered valid on the result of the general examination at the time of opening of Bid Document shall be subject to subsequent detailed scrutiny. Notwithstanding the general examination carried out earlier, the bid receiving authority reserves the right of rejection of any bid which may be found to be defective during the detailed scrutiny.

29. The bidders will offer their rates in the BOQ online in the website for e\_ procurement ([www.wbtenders.gov.in](http://www.wbtenders.gov.in))

30. Prices of the bidders should be inclusive of GST, cess, freight charges, insurance, packing, carriage, loading, unloading, handling, storage, labour, overhead, profit, weigh bill etc. as would be applicable, payable and as necessary including statutory levies by the State Government, Central Government and autonomous bodies as applicable and payable.

31. The right is reserved by the officer inviting the bid to extend the time mentioned in the document as may be considered necessary. Such extension shall be communicated to all concerned in the form of addendum or corrigendum to be uploaded online.

32. The participating bidders will not be entitled to take any undue advantage whatsoever owing to any typographical mistake / omission in anywhere of the Bid Document, if detected subsequently. The same shall immediately be brought to the notice of the Tender Inviting Authority for rectification. However, the Tender Inviting Authority reserves the right to rectify / ratify mistake / omissions if detected, at any point of time even during execution of work.

33. Tender/Bid Inviting Authority reserves the right to accept or to reject any or all bids or to relax any clause without assigning any reason whatsoever. The Tender/Bid Inviting Authority reserves the right to accept either in full or part as deemed necessary.

34. The Tender/Bid Inviting Authority reserves the right to annul the documenting process and reject the bid at any point of time without any obligation to inform the bidder(s) of the grounds for such decisions or action. The Tender inviting Authority shall neither be liable for any such action / decisions nor to be under any obligation to the bidder(s).

35. In the event of execution of any work by the contractor beyond the scope of this tender, separate payment will be made as per actual work to be done on the basis of PWD/P.H.E. Schedule of Rate but the total amount of work done should be within the financial limit of the tender.

36. Provisions and rules for e\_ Tender in vogue is applicable and binding

The Chairman/ Administrator

Burdwan Municipality

**SECTION - L**  
**VENDOR LIST**

**LIST OF VENDORS**

<b>A.</b>	<b>CONSTRUCTION MATERIALS</b>	
1	Cement -	ACC / ULTRATECH / AMBUJA / LAFARGE / L & T / GRASIM
2	Reinforcing Steel -	TATA / SAIL/RINL
2a	Non TATA	SHYAM/ SRMB / CONCAST / ELEGANT



3	Structural Steel -	SAIL / JINDAL / TATA
4	Plasticiser / Water Proofing Compound -	SIKA / CICO/ DR. FIX IT
5	Stone chips -	PAKUR / CHANDIL/PANCHAMI VARIETY
<b>B</b>	<b>EQUIPMENT, VALVES, PIPES &amp; FITTINGS, INSTRUMENTATIONS</b>	
1	G. I. Pipe -	TATA/JINDAL/ UTKARSH /BANSAL
2	M.S Pipes	SAIL / TATA/JINDAL/ UTKARSH /BANSAL
3	C. I. Pipe -	IISCO / ELECTRO STEEL / KESORAM / KEJRIWALL CASTING
4	DI pipe -	ECL/TATA METALICS/ JINDAL
5	UPVC Pipe -	EMCO / ORIPLAST / LONG LAST / SUPREME / SIMPLEX/ TOUGH PLAST/ KARAN / SWASTIK / SKIPPER /DUPOL /PLASTO MOULD (R-CLASSIC)
6	S. W. Pipe -	SONALI CERAMIC PVT. LTD. / SANJOY STONEWARE PIPES / BENGAL STOREWARE PRODUCT
7	NP2 & NP3 Concrete Pipe -	CALCUTTA SPUN PIPES & INDUSTRIES, ARAVINDA SPUN PIPES INDUSTRIES, BHAGIRATHI ENGINEERING
8	Rubber Gasket -	POPULAR RUBBER PRODUCTS / DURABLE POLYMER PRODUCTS (P) LTD/PAUL RUBBER INDUSTRIES.
9	D.I.D.F. Pipe and Fittings -	ELECTRO STEEL CASTING LTD./ KEJRIWALL CASTING / KISWOK
10	DI SPECIALS -	ELECTRO STEEL CASTING LTD./ KEJRIWALL CASTING / KISWOK

11	C.I./Mechanical joints -	ORIENT / LAKSHMI ENGINEERING CORPN/ KEJRIWAL/ UPADHYAY / ELEGANT / MANSAROVAR CASTING
12	CIDF pipes & fittings -	ORIENT / LAKSHMI ENGINEERING CORPN/ KEJRIWAL / UPADHYAY/ ELEGANT/ MANSAROVAR CASTING
13	Sluice Valve and Non Return Valve -	IVC/ KIRLOSKAR / L & T (AUDCO) /VAG/ MCWANE KINNEDY
14	Butterfly Valve -	CRAWLEY & RAY / FOURESS /IVC CAL/L&T (AUDCO) / KIRLOSKAR / KSB
15	Ball Valve -	L&T/BDK
16	Sluice (gate) valve, non	KIRLOSKAR / IVC / AUDCO / KSB /

	return valve -	
17	Pressure Gauge -	BELLS / H.GURU / FEBIG / WIKA/ CAPSTAN
18	Pumps and its accessories -	MATHER & PLATT / KIRLOSKAR / FLOW MORE/WPIL
19	Level indicator -	LEVEON / SB ELECTRO- MECHANICAL
20	Pressure Type Iron Removal Filter	MEI/ SHAKAMBARI ENGINEERING WORKS/ SHITAL – DISH END MFG. WORKS
21	Air Compressor	CROMPTON GREAVES/ KIRLOSKAR/ EVEREST/ JYOTI
22	Air Blower	ABL/ EVEREST/ AIR VAC EQUIPMENT/ SHREEJI/ BLOWVACC
<b>C</b>	<b>MISCELLANEOUS ITEMS</b>	
1	Paint - Primer	
a) Steel Surface -	MURARKA / BERGER/ SHALIMAR/DELUX/ NEROLAC/ JENSON & NICHOL SON/ ASIAN PAINTS	
b) Wood Surface -	BERGER/ SHALIMAR/DELUX/ NEROLAC/ JENSON & NICHOL SON/ ASIAN PAINTS	
2	Paint - Finishing Coat	
a) High Gloss Synthetic Enamel for Steel / Cast Iron & Wood Surface -	BERGER/ SHALIMAR/DELUX/ NEROLAC/ JENSON & NICHOL SON/ ASIAN PAINTS	
3	Cement Based Decorative Wash -	SUPER SNOWCEM / DURACEM/STARCEM
4	Weather Coat -	BERGER/ SHALIMAR/DELUX/ NEROLAC/ JENSON & NICHOL SON/ ASIAN PAINTS
5	Sanitary Ware -	HINDUSTAN / PARRY / NYECER
6 D	a) Bib Cock -	ESSCO / JAGUAR
	b) stop cock	ESSCO / JAGUAR

**Note:**

- 1) Acceptance of the Department is mandatory to finalize the make of materials and equipment prior to ordering by the successful tenderer. Engineer-in-Charge / Superintending Engineer, / Technical Committee, M.E.Dte.may include or omit any vendor in the vendor list in concurrence with the report of quality assurance agency engaged by the department subsequently.
- 2) The successful bidders shall have to furnish list of vendors to the department from the above list for approval. Acceptance of the department is mandatory to finalize the make of the equipment, prior to ordering by the successful bidder. No other equivalent make other than mentioned above will be accepted.
- 3) Any other materials required for the work but not mentioned in the above list, shall be procured from approved list of vendors of ME Dte. Acceptance of the department is mandatory to finalize the

make of the materials/ equipment, prior to ordering by the successful bidder.

4) Use of reinforcement other than TATA/SAIL/RINL may be allowed and in that case the manufacturer should be enlisted in the approved vendors' list of MED W. B. Rate will be reduced Per M.T of reinforcement consumed in the work.

**The Executive Officer  
Burdwan Municipality**

**SECTION - M  
WBF2912**

**SECTION - N  
PRICE BID  
(To be inserted in financial bid)**

# DRAWING

**SURVEY DRAWING OF RISING MAIN FROM PROPOSED RADIAL WELL AT DAMODAR RIVER TO PROPOSED WTP AT JALKAL PARK**

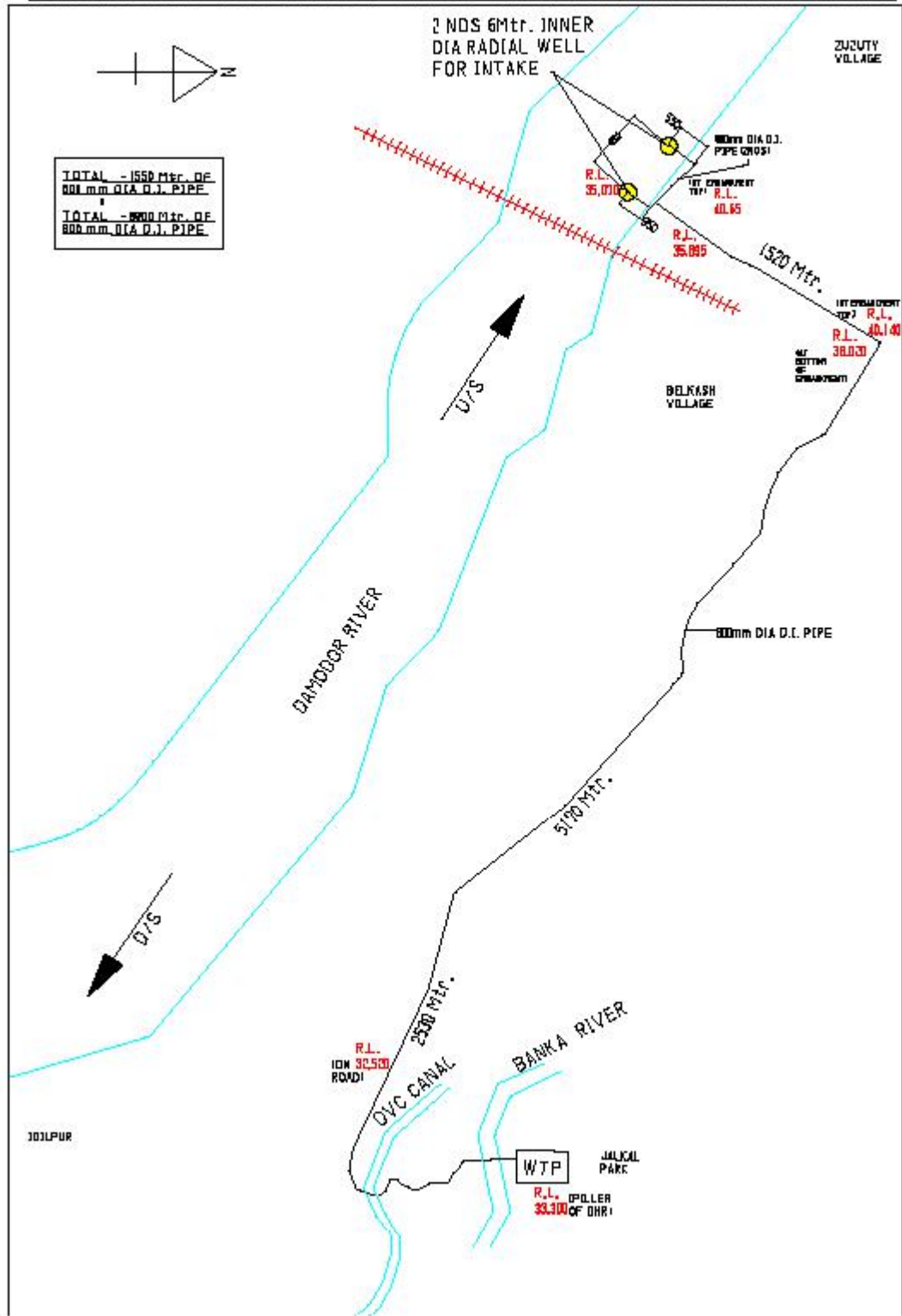

DETAILS OF PERMANENT ROAD RESTORATION  
WORK FOR APPROACH ROAD IN DIFFERENT  
LOCATION FOR WATER SUPPLY SCHEME UNDER  
AMRUT PROGRAMME OF BURDWAN MUNICIPALITY.

Seal coat (Typ-B)

20 mm thk. Premix chipping carpet.

75 mm thk. Bituminous Macadam

100 mm thk. stone metal consolidation.



200 mm thk. brick bats consolidation

150 mm thk. Sand filling

CROSS SECTION OF  
BITUMINOUS PAVEMENT (APPROACH ROAD)

200 mm thk. brick bats consolidation

150 mm thk. (1:1.5:3) C.C. road



150 mm thk. Sand filling

CROSS SECTION OF  
CONCRETE PAVEMENT (APPROACH ROAD).

## RADIAL COLLECTOR WELL

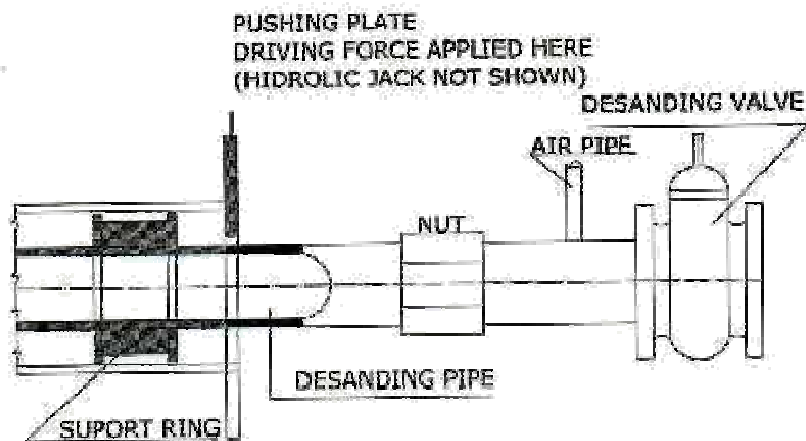
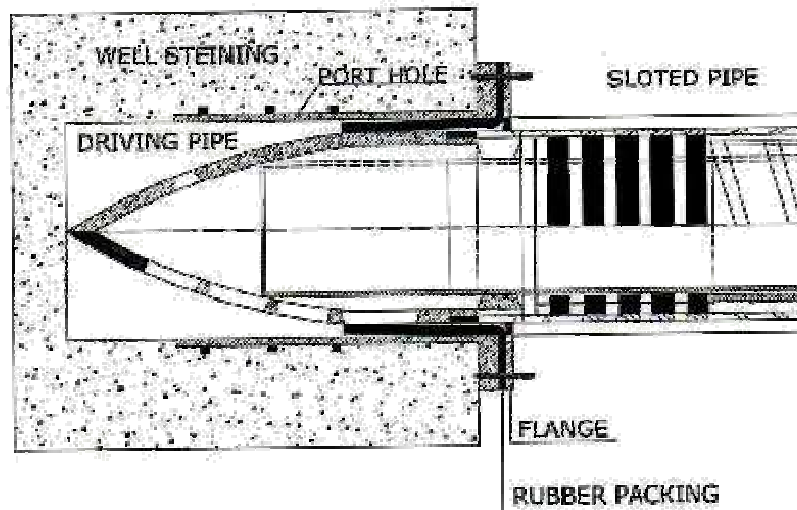

**ARRANGEMENT FOR DRIVING  
HORIZONTAL SLOTTED PIPE**

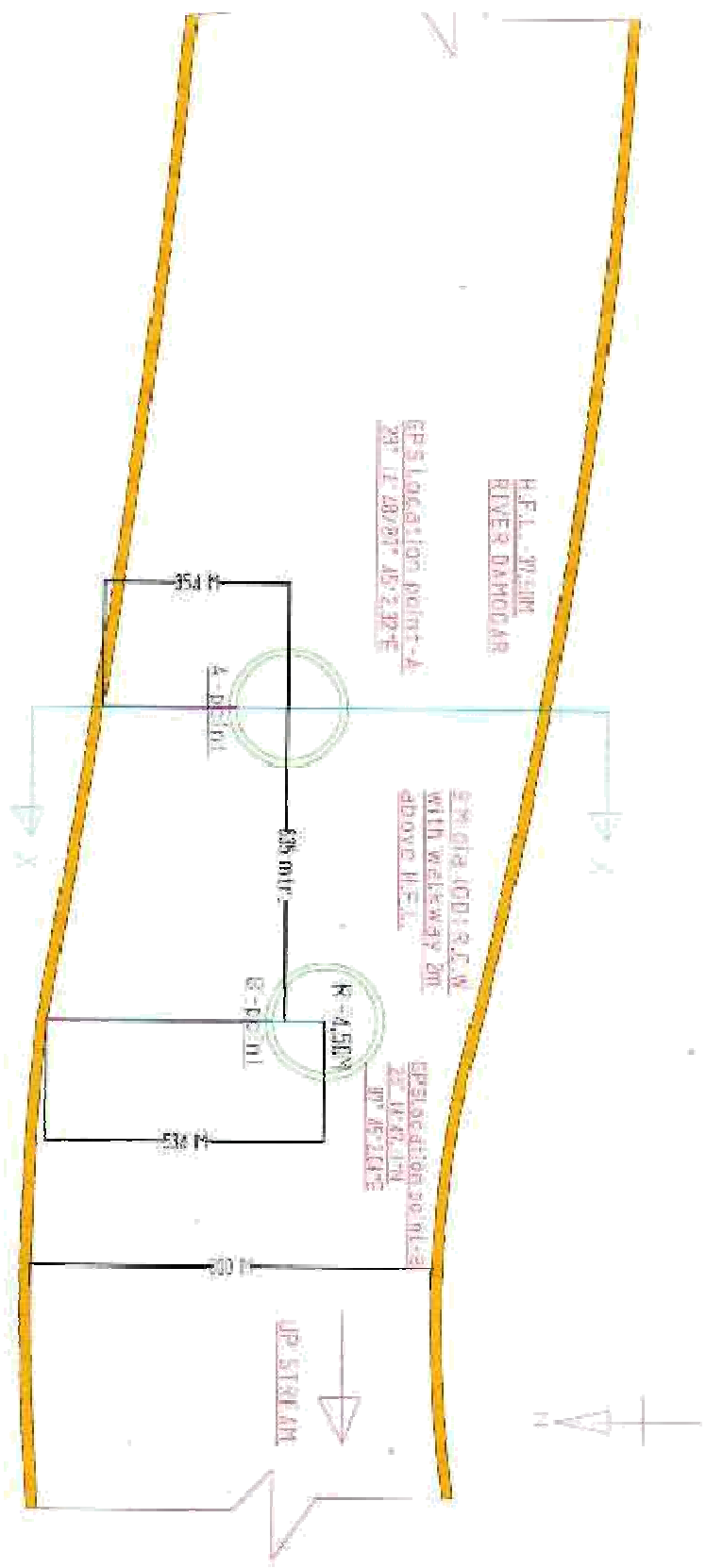

H.F.L. - W/SUM  
RIVER DAHODAR

EP S Location Point-A  
281.17 280.97 45.2.32-E

500 dia. (0.152 m)  
with waterway 2m  
above H.F.L.

EP S Location Point-B  
281.17 280.97 45.2.32-E

UPSTREAM

PLAN

1"

GPS Location Point - A  
23° 14' 48" N 105° 23' 27" E

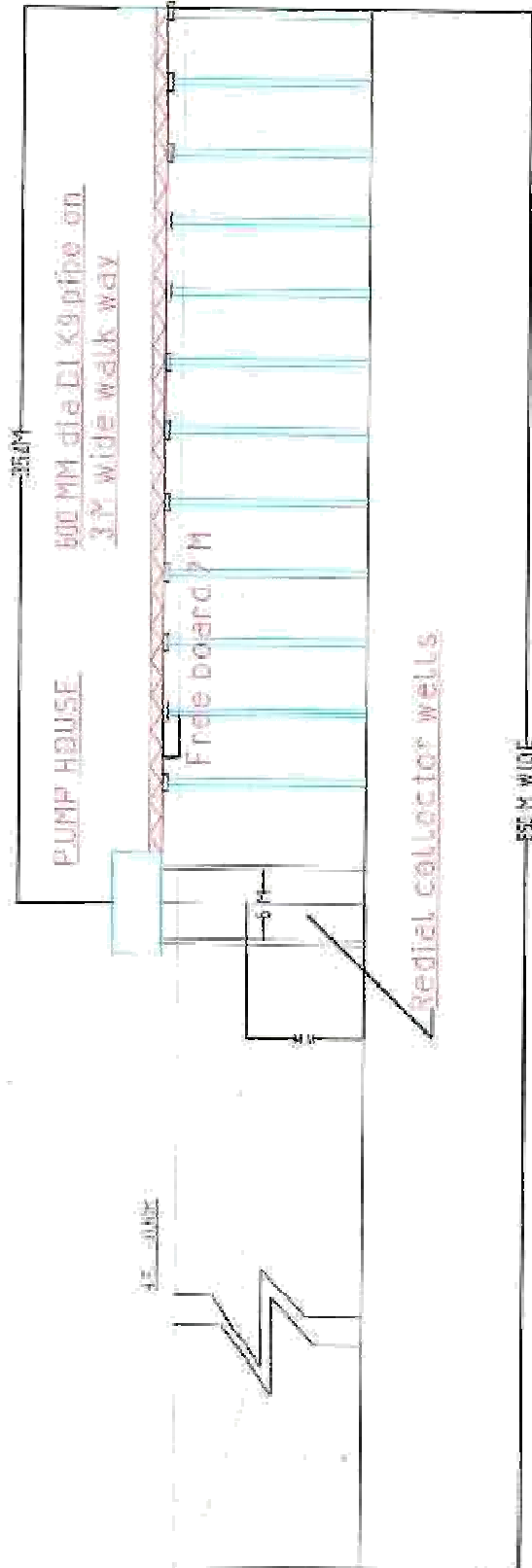

CROSS SECTIONAL DRAWING



## **DRAWINGS**

### **1.0 ARCHITECTURAL / CIVIL GENERAL ARRANGEMENT DRAWING, PIPING & INSTRUMENTATION DIAGRAM**

Architectural drawings / Civil General Arrangement drawings including P.I diagram for all components of works as per scope of work, specification, Tender document and direction of EIC should be prepared by the successful bidder based on the design parameters, technical data as per relevant I.S codes with latest amendments, CMEDEO Manual on Water Supply and Treatment and Standard construction practices etc. unless otherwise mentioned elsewhere. The successful bidder should submit 6(three) copies of Architectural drawings / Civil General Arrangement drawings both hard and soft copies for necessary approval of the appropriate authority in MEDDte. Some of the works will be executed as per departmental design and drawings and departmental drawings will be issued to the successful contractor for these components. Construction and installation works should be carried out as per approved drawings and any modification or correction thereof accepted and approved by the EIC.

### **2.0 STRUCTURAL DRAWING**

The successful bidder should carry out structural design of all components of works as per approved Architectural drawings / Civil General Arrangement drawings, soil test report, specification, scope of work, I.S:456-2000, I.S: 3370 -2009 Part-I to IV, I.S: 1893 -2005, I.S: 875, I.S:800 and other related I.S codes with latest amendment, considering seismic zone –IV and Importance Factor 1.5. The success bidder should submit 6 (three) copies of design report & structural drawings (both hard and soft copies) for necessary approval of the appropriate authority in MEDDte. Some of the works will be executed as per departmental design and drawings and departmental drawings will be issued to the successful contractor for these components. Construction and installation works should be carried out as per approved drawings and any modification or correction thereof accepted and approved by the EIC.

### **2.5 COMPLETION DRAWING**

All components of works under this Tender should be constructed as per approved Architectural drawings, Civil General Arrangement drawings, Piping & Instrumentation Diagrams, Structural drawings, specification, scope of work, Tender document and direction of the EIC. Any change in design and drawings approved by the EIC during construction should be incorporated in working drawings. The successful bidder should submit 6(three) copies of completion drawings (both hard and soft copies) incorporating all such changes (if any) after completion of work in all respects as per direction and satisfaction of the EIC. Submission of completion drawings is the prerequisite for release of final payment.

**ANNEXURE – I**

**Soil / Sand Hydro-geological Investigation Report for Collector well Structure Survey Report  
of Jadavpur University**

**Table 6.2 Result summary of design of recommended Radial Collector Well**

Name of the river	Name of the Block (Name of the Village)	Transmissivity (T) (m <sup>2</sup> /d)	Saturated Aquifer thickness (H) (m)	Max. Permissible Entrance Velocity (v <sub>e</sub> ) (mm/s)	Q <sub>0</sub> , Maximum available yield		Diameter of Cassion (m)	Radius of Influence (R) (m)	N, Required no. of radials no	Screen diameter mm
					MLD	MGD				
Da mod ar	Zuzuty	2500	12.5	3	22.5	5	6.0	634	24	400

**LOCATION OF RADIAL COLLECTOR WELLS**

On the basis of above investigation two points ( GPS location of point -0 23°14'48.12"N 87°45'2.32"E and point-1 23°14'47.11"N 87°45'2.04"E) are recommended for the construction of radial collector well in section 0-0' and Section-1-1' of slim boring operation also depicted in the Figure no- 6.5

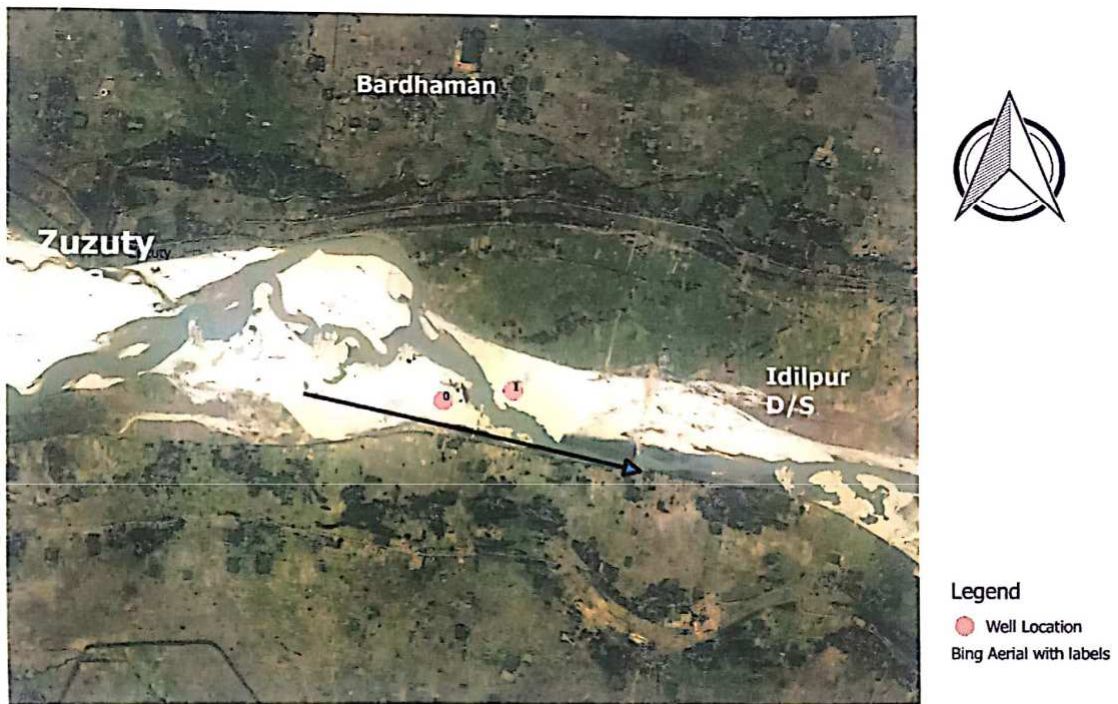

**Figure 6.5: Recommended location for collector Well**

*Dr. Asis Mazumdar*  
**Dr. Asis Mazumdar**  
**Professor & Director**  
**School of Water Resource Engineer**  
**Jadavpur University, Kolkata-700 032**

## 7.0. WATER QUALITY ANALYSIS AND RECOMMENDATION

Water samples were collected on 21/12/2019 2012. Sampling was conducted between 10 a.m. and 6 p.m. based on weather conditions. All the parameters measured and water quality parameter was analyzed according to APHA method. The results of water quality parameter in Damodar are listed in Table 7.1.

**Table 7.1 Water Quality result**

Water Quality Parameters	Value
pH	8.32
Turbidity (NTU)	2.99
TDS (ppm)	93.7
Alkalinity (mg/l)	16.92
Total Hardness (mg/l)	148
Fluoride (mg/l)	0
Chloride(mg/l)	34
TC	1400 colonies
FC	NIL
Iron (mg/l)	0.5
Arsenic(mg/l)	BDL

Water quality analysis report indicates presence of Turbidity more than the acceptable limit of Drinking Water Specification- BIS 10500:2012 (1 NTU) but less than the permissible limit. Though Faecal Coliform was absent in water but presence of Total Coliform (1400 Colony Count) indicated bacterial contamination in raw water. All other parameters as per water quality analysis report were found to be within acceptable limit of BIS 10500:2012.

In the above context following treatment of water is suggested:

1. Disinfection of water by chlorination is to be carried out before water supply. Residual chlorine is to be maintained in the water supply but residual chlorine should not be more than 0.2 mg/l at consumer points.
2. It is preferred to supply water to the consumers having turbidity less than 1 NTU (within acceptable limit). Again, turbidity value of raw water may change seasonally. But in no case the turbidity of supply water would be more than 5 NTU (Max. permissible limit). So, raw water quality needs to be analysed atleast monthly basis to ascertain the turbidity of raw water. If turbidity exceeds to 5 NTU then there must be arrangement of filtration of water.

## 8.0. CONCLUSION & RECOMENDATION

Based on the VES, Lithological and Hydrogeological investigation pertaining to site selection, design considerations and site constraints, for the stretch from Idilpur to Zuzuty along river Damodar , following recommendations may be drawn in order to augment the water supply of Burdwan Municipality.

- Two radial collector wells, are recommended (GPS location of point -0 23°14'48.12", 87°45'2.32"E and point-1 23°14'47.11"N 87°45'2.04"E) and depicted in Figure 6.5
- Each Radial Collector has been designed with a maximum safe yield 5 MGD.
- 24 laterals are to be placed in two layers each having 12 lateral spaced uniformly at 30° around the circumference of the caisson of diameter 6 m. The layer may be placed at 7.62m and 10.668m.
- The water treatment needed is depicted above in section-7.0
- **The neighboring stretch of Damodar River under present project is subjected to sand mining as observed during the study. The present position of the radial collector well is suitable for the designed yield of 5 MGD each so far the present sand bearing strata of river bed is concerned as found during the investigation. If sand mining starts within 1.5 km from both upstream and downstream of the radial collector well, the sustainability of water withdrawal will be jeopardized.**

  
04/02/19  
Dr. Asis Mazumdar  
Professor & Director  
School of Water Resource Engineer  
Jadavpur University, Kolkata-700 032

Government of West Bengal  
Office of the Assistant Engineer, Burdwan Sub Division, P.H.E.Dic.  
P.H.E. Complex, Nababhat, Purba Bardhaman.  
Burdwan District Laboratory

Memo No. .... /BSD.

Dated, Purba Bardhaman, the ..... 2019

Results of Chemical & Bacteriological analysis of water sample

Water sample of ----- Burdwan Municipality  
Purba Bardhaman  
Samples received from ----- Executive Officer Of Burdwan Municipality  
Sample Taken from ----- The Bed of Damodar River at Jimjhuti  
Sample Collected by ----- Sampling Assistant of Burdwan District Labo.  
Sample received on ----- 28.08.2019.  
Sample reference no ----- 9352

Parameters	Observed Values	Limits as per IS 10500-2012 (Second revision)	
		Acceptable limit	Permissible limit
<b>Chemical Analysis</b>			
pH value	6.69	6.5 to 8.5	6.5 to 8.5
Turbidity (NTU)	15.00*	1	5
Total Dissolved Solids (mg/l)	81	500	2000
Total Hardness as CaCO <sub>3</sub> (mg/l)	48	200	600
Iron (mg/l)	1.09*	0.30	1.00
Arsenic (mg/l)	BDL	0.01	0.05
Chloride (mg/l)	10.28	250	1000
Fluoride (mg/l)	BDL	1.00	1.50
Nitrate (mg/l)	0.26	45	45
<b>Bacteriological Analysis</b>			
Total Coliform Count (CFU/100ML)	136*	0	0
Fecoli Count (CFU/100ML)	84*	0	0

BDL - Below Detectable Limit

\*Above the Permissible Limit

Stamp  
28.8.19  
Bacteriologist  
Burdwan Dist. Laboratory  
P.H.E.Dic.

Stamp  
28.8.19  
Chemist  
Burdwan Dist. Laboratory  
P.H.E.Dic.

Stamp  
29/8/19  
Junior Engineer  
Burdwan Sub-Division  
P.H.E.Dic.

Stamp  
Assistant Engineer  
Burdwan Sub-Division  
P.H.E.Dic.

**The Executive Officer  
Burdwan Municipality**

## **ANNEXURE - II**

### **LIST OF DOCUMENTS TO BE FURNISHED**

List of instruments supplied by bidders have to be furnish by bidders and will be uploaded in Technical Document 2 folder with digital signature.

1. Pump thrust bearing housing details.
2. Pump non-reverse ratchet details.
3. Finally approved pump house layout with load data.
3. Finally approved single line diagram of the electrical system and earthing.
5. Cable schedule and termination chart.
6. GA details of L.T. Board at pumping and substation.
7. Schematic power wiring drawings (M.V), panel wise.
8. Schematic Control Wiring drawings panel wise.
9. List of authorized service centres of individual equipment.
10. List of special tools & tackles required for effective installation & maintenance.
11. Installation, operation, maintenance manuals for all equipment.
12. Completion drawings for all electrical circuit diagrams, layout Terms & Conditions. (The drawings etc. shall be furnished on transparency along with the copies mentioned).



**ANNEXURE - IV****LIST OF VENDORS**

Sl. No.	Equipment / Instrument	Make
01.	Pumps	KIRLOSKAR/WPIL/ MATHER& PLANT
02.	Motors	SIEMENS/KBL/ABB/CG/MATHARON
03.	MCC	LARSEN & TOUBRO/SIEMENS/ /ABB/SELWIN/AC POWER
03.	Electrical component	LARSEN & TOUBRO/SIEMENS/RNR/ABB
05.	Power distribution board	L & T/SIEMENS /ABB/SELWIN
06.	Hoist	INDEF/ROPEMASTER/SUREKHA
07.	Valves (Sluice/Butterfly/NRV)	KIRLOSKAR/IVC/KSB/AUDCO
09.	Pressure Gauge	H.GURU/BELLS
10.	Ammeter, Voltmeter	AE / IMP/ L&T
11.	Control Switchs.	SIEMENS / L&T / ABB
12.	Push buttons, Selector Switches, Indicating Lamps	SIEMENS / L&T / ABB
13.	Air Circuit Breakers	ABB/GE/LARSEN & TOUBRO/ABB/SIEMENS/SCHNEIDER
13.	Power Cable (Aluminum)	HEAVELS/GLOSTER/NICCO/FINOLEX/Crystal/Mescab
15.	Control Cable (Copper)	HEAVELS/ FINOLEX/Crystal/GLOSTER/RR Kabel
16.	HRC Fuse	LARSEN & TOUBRO/SIEMENS/GE
17.	Contractors	LARSEN & TOUBRO/SIEMENS/GE
18.	Overload Relays	SIEMENS/GE/LARSEN & TOUBRO/AVK-SEG & CONTROLS (I) LTD/CUTLER HAMMER
19.	Local start / stop Push button switch	SWITCHGEAR AND ACCESSORIES/ SIEMENS/L&T
20.	Current Transformers	CROMPTON/BHARAT BIJLEE/EMCO/KAPPA



21.	OC/EF & Under voltage	EE/LARSEN & TOUBRO/ABB
22.	Capacitor	CROMPTON/NCEF/UNISTAR
23.	Light Fitting including Lamps & Tubes.	PHILIPS/HEAVELS/CROMPTON/K-lite (all light fittings should be LED with 5 yrs guarantee by the manufacturer)
23.	Ceiling Fans & Cabin Fans	GEC/ CROMPON/HEAVELS
25.	Exhaust Fans	GEC/ CROMPON/HEAVELS
26	15-A Industrial Plug Socket outlets.	HEAVELSA/ANCHOR
27.	Multi-range Tongue Tester	MOTWANE
28.	Avo-meter	MOTWANE/HITACHI
29.	50.0 Volt Meggar	HITACHI/MOTWANE
30.	Paints	ASIAN PAINTS/ ICICI/ JONSON & NICHOLSON/ SHALIMER/ BERGER
31.	Epoxy Resin	CIBA - GEIGY
32.	Fibre Glass	MAT FIBRE GLASS PILKINGTON
33.	Flow meter	ABB/SEIMENCE/EH/ Kone Marshal
33.	Temper proof air release valve	KBL/IVC
35.	Power Transformer	SCHINIDER/ KEC/ CG/ BHEL/Voltamp/RPG Reychem
36.	HT VCB	ABB/SEIMENSE/SCHINIDER/CG/VOLT AMP/ANDRULE/STELMEC

**The Executive Officer  
Burdwan Municipality**

## ANNEXURE - V

### LIST OF DEVIATIONS

The Bidders are advised to fill up the list of deviations, they indicate/sought for in their offer, showing the specifications & the deviations wanted backed by all clarifications & justifications.

If there is no deviation sought, the Bidder must indicate NIL in the list.

Sl. No.	Items	Details as per Bid specification	Details of the offer	Reason for which such deviation sought for with technical backup

**Signature of Bidder**

**The Executive Officer  
Burdwan Municipality**

**Signature Not Verified**

Digitally signed by JOY BANJAN SEN  
Date: 2019.09.30 18:42:41 IST  
Location: West Bengal-WB

